



2015

**GUIDE TO NATURAL
REFRIGERANTS IN CHINA**

— STATE OF THE
INDUSTRY

published by



in cooperation with



AIR

CO₂

R1150

R1270

R290

NH₃



RefComp

丙烷螺杆压缩机
R290 Screw Compressor

天然工质
Natural Refrigerant



SRMTEC

二氧化碳螺杆压缩机
CO₂ Screw Compressor

公司产品还包括:

We also have the following products:

- 氨制冷压缩机
- 空气制冷压缩机
- 水制冷压缩机
- NH₃ compressor
- Air refrigerant compressor
- R718 refrigerant compressor



SRMTEC

变频氨制冷压缩机组
Convertible-frequency NH₃ Screw Compressor Package



SRMTEC

二氧化碳载冷剂机组
CO₂ Brine Chiller



SRMTEC

二氧化碳/氨复叠制冷机组
CO₂/NH₃ Cascade Refrigeration System



更少的制冷剂充注量, 更好的安全保证!
Less Refrigerant Charge, More Safety



2015 GUIDE TO NATURAL REFRIGERANTS IN CHINA – STATE OF THE INDUSTRY

THIS PROJECT WAS SUPPORTED BY

Panasonic

Panasonic Appliances Compressor (Dalian) Co., Ltd.

The information in this report, or upon which this report is based, has been obtained from sources the authors believe to be reliable and accurate. While reasonable efforts have been made to ensure that the contents of this publication are factually correct, shecco does not accept responsibility for the accuracy or completeness of the contents, and shall not be liable for any loss or damage that may be occasioned directly or indirectly through the use of, or reliance on, the contents of this publication.

© 2015 shecco

All rights reserved.



Marc Chasserot

Publisher / Managing Director
of shecco

Welcome message by Publisher

A year ago, when shecco decided to start work on the first-ever comprehensive report on the market, technology and innovation potential for natural refrigerants in China, we were not sure how responsive the Chinese industry would be to such a project. Because, maybe our market review would come too early in time to truly capture the business case for natural refrigerants in China - a country that thanks to its large domestic market, rising living standards and its export capabilities to the global HVAC&R industry, will be at the forefront of driving the use and production of more sustainable heating, refrigeration and air conditioning systems.

Today, we are proud to publish what we believe is the most complete overview of the state of the industry in China for five natural refrigerants: ammonia, carbon dioxide, hydrocarbons, water and air. Not only does the report include the insights of nearly 1,100 responses from the Chinese HVAC&R industry on the opportunities and remaining challenges for natural refrigerants in China. It also features a range of detailed market maps, showing the distribution of natural refrigerants in the industrial, commercial and light commercial refrigeration sectors, in heat pumps, as well as in room air conditioners throughout China.

This is shecco's fifth comprehensive publication about a world region's market potential for f-gas free refrigerants, following on from the 'GUIDE' publications for Europe in 2012 and 2014, as well as developing countries and North America in 2013. I am confident that GUIDE China can play an instrumental role in helping market leaders and end users find out exactly where the market in China is heading and hence plan better for the coming years.

I hope you enjoy reading this report. We all very much look forward to further sharing needed knowledge to capture together the business case - current and future - for natural refrigerants in China.



Nina Masson

Lead Author & Deputy Managing Director
of shecco

Welcome message by Lead Author

Increasingly, we are seeing the global 'pivot to the East' and collectively we are realising the strong role that China will - and already is - playing in the world economy; and the effect that this will have on our environment. Therefore, it is encouraging to see that there are positive signs emerging from China as a world leader in the heating, refrigeration and air conditioning industry; especially for the role natural refrigerants will play in this global paradigm shift.

This GUIDE is the most up-to-date and comprehensive report about the current use of, and future potential, of natural refrigerants in China. It identifies and clearly presents the emerging and established market trends, business opportunities and policy drivers for natural refrigerants in China. At the same time, it also outlines suitable applications and case studies for f-gas free solutions in the heating, cooling and refrigeration sectors.

The high amount of collected responses among China's HVAC&R experts for the industry survey conducted for this GUIDE is indicative of the growing excitement, both within the global natural refrigerants community, but more specifically, the Chinese market. It provides a comprehensive picture of China's key motivations, barriers and drivers for the future growth of the natural refrigerant technology market.

Further to that, the report also features exclusive interviews with government agencies, the research community, domestic technology suppliers, end users, as well as international companies that have invested in building the emerging natural refrigerant ecosystem in China. They complement the survey findings with a more personal glance at the state of the industry.

The report, and its individual stories, put forth evidence that a stronger focus on environmentally sustainable, and at the same time economically viable HVAC&R technologies, can solidify the region's position as a world leader in a range of sectors, such as NH₃/CO₂ industrial refrigeration, CO₂ heat pumps, R290 room air conditioners, CO₂ supermarkets, and in f-gas free light-commercial refrigeration. In fact, the variety of sectors that have the potential to transition away from the use of fluorinated gases towards long-term viable natural substances, is astounding. However, one should not forget that barriers remain and that a much stronger commitment from legislators and the industry is needed to fast track the adoption of natural refrigerant-based technology.

In summary, the overall message is clear: China has the building blocks in place to be a major market supplier and user of natural refrigerants in the coming five years, and for sure in the run-up to a global HCFC phase-out by 2030. By informing both domestic and international end users, suppliers and legislators about the current landscape and future market potential, it is hoped that this GUIDE can facilitate this important process.

Welcome message by CAR

The refrigerant selection and development of refrigeration technologies dates back to early developments of vapour compression technology. However today, manufacturers and end user have to not only consider performance, safety, and economic factors, but also our environmental responsibility to protect the ozone layer and reduce greenhouse gas emissions. History dictates that natural refrigerants have always played a significant role, in particular in industrial and commercial refrigeration, sectors which each have their own unique advantages. The former president of the IIR (International Institute of Refrigeration), Mr. Lorentzen, considered natural refrigerants to be the ultimate solution to ensure environmental protection. In recent years, China has achieved relatively rapid development, particularly in the research of natural refrigerants solutions. To understand and effectively analyse the various applications of natural refrigerant systems in China today, CAR is delighted to be working with shecco on the industry survey for the GUIDE. We hope the GUIDE can act as an effective informative tool to help share the experiences and results from the survey, and continue to promote Chinese HVAC&R industry development.

Jin Jiawei
Secretary-General
Chinese Association of Refrigeration



Official partner of GUIDE China 2015

Welcome message by Panasonic

In recent years, energy saving and carbon emission reductions have become a global concern. There are now stronger arguments for the curtailment of greenhouse gases through a societal reorientation to a culture that doesn't rely on fossil fuels, and instead seeks renewable energy. In this process, the HVAC&R industry, as one of the largest consumers of energy must look for an alternative to traditional fluorinated refrigerants. In natural refrigerants, there already exists an alternative and one that is now receiving unprecedented attention due to its environmentally friendly and excellent thermal properties features, especially CO₂.

Panasonic Appliances Compressor (Dalian) Co., Ltd. adheres to the Panasonic Group's core value that "enterprises are instruments of society". Through continuous technological innovation, we have established CO₂ compressors and solutions in the market for many years. By providing a wide range of solutions for heat pump water heaters, heat pump dryers and commercial refrigeration applications, we are contributing to the industry's sustainable development, prosperity and to the perpetual well being of mankind.

Nobuo Yoshida, General Manager
Panasonic Appliance Compressor (Dalian) Co., Ltd.

Panasonic

Panasonic Appliances Compressor (Dalian) Co., Ltd.

Special supporter of the GUIDE China 2015

Table of contents

WELCOME MESSAGE BY PUBLISHER	6
WELCOME MESSAGE BY LEAD AUTHOR	7
WELCOME MESSAGE BY CAR	8
WELCOME MESSAGE BY PANASONIC	9
ABOUT THIS GUIDE	16
A short overview	16
Chinese industry survey about natural refrigerants	18
Introduction	18
Detailed analysis of natural and non-natural refrigerant users	19
Exclusive interviews	22
Overview of profiles	22
About natural refrigerants	26
Carbon dioxide	27
Ammonia	27
Hydrocarbons	28
Water	28
Air	29

APPLICATION OF NATURAL REFRIGERANTS IN CHINA TODAY: MARKET, TECHNOLOGY & POLICY OVERVIEW	30
Introduction	30
Market and technology trends	31
Exclusive interviews - Market trends & drivers	36
Policy trends	43
Exclusive interviews - Policy	48
An ecosystem approach	50
City & buildings	52
Industry, special applications & sports	56
Food chain	60
MARKET POTENTIAL FOR NATURAL REFRIGERANTS IN CHINA TOMORROW	66
Introduction	66
Future trends for natural refrigerants	67
Growing number of new entrants contributes to market transformation in the future	67
Exclusive interviews - Market for the future	71
Exclusive interviews - Action plan for faster introduction of natural refrigerants	74
Exclusive interviews - Policy for the future	78

KEY APPLICATIONS FOR NATURAL REFRIGERANTS IN CHINA	80
Industrial refrigeration	80
Exclusive interviews - Industrial refrigeration	88
CASE STUDY: Danfoss' award-winning valve station applied in a landmark CO ₂ refrigeration project	90
Commercial refrigeration	92
Exclusive interviews - Commercial refrigeration	98
CASE STUDY: Alfa Laval's CO ₂ refrigeration system at the S-Market building in Helsinki, Finland	102
CASE STUDY: Haier-Carrier pump CO ₂ system installed at Ningbo store	104
CASE STUDY: Carel's solutions for transcritical CO ₂ system installed in Carrefour in Italy	106
Light-Commercial refrigeration	108
Exclusive interviews - Light commercial refrigeration	114
CASE STUDY: New innovation products for environmental-protection: Panasonic CO ₂ 2-stage rotary compressors	116
CASE STUDY: Secop - XV Compressor for R600a – A new standard for cool savings	118
Heat pumps	120
Exclusive interviews - Heat pumps	126
CASE STUDY: Panasonic - CO ₂ low temperature heat pump heating system	128
CASE STUDY: Panasonic - CO ₂ heat pump water heater system	130
Room air conditioning	132
Exclusive interviews - Room air conditioning	139
REFERENCES	141
ABOUT THE AUTHORS	150

■ CO₂压缩机应用
CO₂ Compressor Application

Panasonic

Panasonic Appliances Compressor (Dalian) Co., Ltd.

Heating
制热

Heat Pumps for Space Heating
采暖用热泵

Commercial Heat Pump
Water Heaters
商用热泵热水器

Domestic Heat Pump
Water Heaters
家用热泵热水器

Heating and Cooling
Combined Products
制冷制热双应用产品



CO₂ Compressor
Technologies
二氧化碳压缩机技术



Light Commercial
Bottle Coolers
轻型商用饮料柜

Commercial Refrigerators
and Freezers
商用冰箱、冷冻柜

Cooling
制冷

■ 双级压缩机结构 (内部中压)
2-stage compression mechanism (Intermediate pressure)

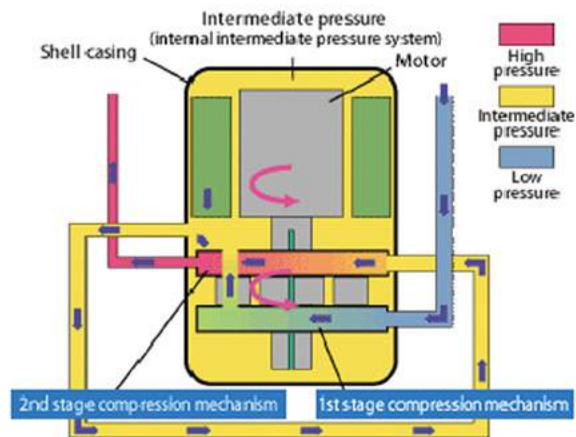

■ 制冷循环应用
Application in refrigeration cycles

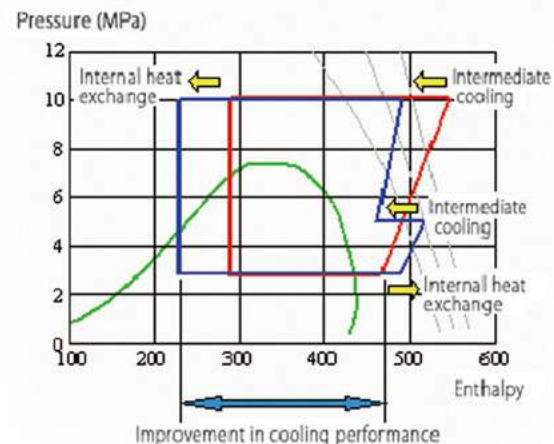

■ 制冷、制热应用CO₂压缩机
CO₂ Compressor for Heating/Cooling
Line up 机型系列

类型	Type	功率 Output	应用 Application
15F 卧式	15F Horizontal	400~750W	自动售货机、饮水机、玻璃门冷柜和热泵 Vending Machines, Fountains, Glass Door Bottle Coolers, and Heat Pumps
15F 立式	15F Vertical	300~500W	
15F 立式变频	15F Vertical DC Inverter	400~1500W	
20F 立式变频	20F Vertical DC Inverter	3000W	中小型展示柜和热泵 Small to Medium Open Front Showcases and Heat Pumps
33F 立式变频	33F Vertical DC Inverter	7500W	超市陈列柜和热泵 Supermarket Remote Showcases and Heat Pumps

在世界范围内已取得电气安全认证。(欧洲VDE, 中国CCC, 北美UL)
Certified to worldwide electricity and Safety standards.(VDE for Europe,CCC for China,UL for North America).

所有产品图片仅供参考, 以实际订货产品为准, 参数如有变动恕不另行通知。
All of the pictures in catalogues are only for your reference and subject to the actual products. Parameters are subject to change without notice.

About this GUIDE

A short overview

To ensure a fruitful and efficient reading, what follows is a detailing of the separate chapters that make up the GUIDE to Natural Refrigerants in China – State of the Industry 2015.



Chapter 1 – About this GUIDE – This chapter serves as a simple introduction to the world of natural refrigerants and what will be coming up later in the GUIDE. Naturally, this chapter starts with detailing the ‘natural five’ refrigerants: ammonia, carbon dioxide, hydrocarbons, water and air. This section provides information over their chemical, physical, technical and environmental properties.

Following this, the respondent profile of the largest ever survey of China’s natural refrigerant market will be presented, including the average size of the respondents’ firms, the type of firm they work in and the application area they work within. After introducing the survey respondent profile, the profiles of the interviewees that span government, business and academics spheres, will be listed.

Chapter 2 – Application of Natural Refrigerants in China TODAY – Market, Policy and Technology Overview – Through the use of an independent research, survey and interviews, this section provides a comprehensive and far-reaching evaluation of the current composition of the Chinese natural refrigerants market. A clear focus is given to the key drivers that are emerging in China in three different spheres: the market for natural refrigerants, the current policy climate and technological development.

The chapter conveys these varied applications in an intuitive format in three “ecosystems”: City & Buildings, Industry, Special Applications and Sports, and Food Chain. The purpose of the “ecosystems” is to highlight the variety of natural refrigerant products and technologies currently in use in China. The variety of applications available for natural refrigerant technology highlights the huge scope of adoption potential for natural refrigerants in China.

Chapter 3 – Market Potential for Natural Refrigerants in China

TOMORROW – Offers exclusive insights from the industry survey and from interviews with industry experts. This chapter helps draw a blueprint of the industry's plan for provision and use of natural refrigerants in the future. The survey provides a clear indication to expectations regarding the future market share in 2020 and 2030 in different applications for different refrigerants; and important factors that will drive the market. The interviews, however, provide a more micro-forecast of future policy, technology and market developments for natural refrigerants and individual recommendations for the market to accelerate; directed at both government and the industry.

Chapter 4 – Overview of Key Applications in the Chinese Market

Market – This chapter focuses on the five major applications for natural refrigerants in the Chinese market. These are: industrial, commercial and light commercial refrigeration, heat pumps and room air conditioning (RAC). These key sectors show a dynamic development in terms of market uptake of natural refrigerants in the last few years and are expected to develop even faster in the coming years. Essentially: The applications to look out for.

Industrial refrigeration – highlights the progress of CO₂ and ammonia usage in industrial applications as well as the increased concern over safety and energy efficiency in industrial applications, in part sparked by the rapid construction of the cold chain in China today. The chapter presents a CO₂ industrial refrigeration map depicting the trends in use of CO₂ as a refrigerant in this application.

Commercial refrigeration – By drawing examples from leading end users such as Tesco and Metro in China, the existing barriers to wider uptake of natural refrigerants are highlighted. It also offers a global comparison with examples from the EU, Japan and North America to highlight the untapped potential for this application in China. A map indicating the current number of supermarkets in China using CO₂ as a refrigerant, is also included.

Light commercial refrigeration – This section highlights the commitment of leading end users of global consumer brands in CO₂ and hydrocarbon-based solutions in the Chinese market as a big driver. Through primary data collection, this section provides the current market size for natural refrigerant-based light commercial equipment.

Heat pumps – Introduces the market for CO₂ heat pumps in China and the industry's technological development process over the last few years. The chapter outlines the current challenges facing the market and a prediction of the future market potential. The chapter provides the current number of CO₂ heat pumps introduced into the Chinese market for commercial use.

Room air conditioning – Summarises the current progress of production line conversion to R290 as a refrigerant in room air conditioning (RAC). At the same time, this chapter analyses the challenges related to standards and training of technicians that the industry and government need to focus on to facilitate market penetration of these products. These findings are compared with India's R290 RAC market to show where realistic improvements can be made.

Chinese industry survey about natural refrigerants

Introduction

In order to provide an accurate current market share of natural refrigerants in China, and the future outlook for the use of the technology, shecco conducted an online survey among experts in the Chinese HVAC&R sector. The Chinese and English bilingual survey, launched in August 2014 and distributed to over 18,000 Chinese HVAC&R experts, active in both natural refrigerants and non-natural refrigerants-based technology, received 1,098 individual responses from a wide variety of organisations. This survey collection is therefore the largest natural refrigerant survey ever conducted for the Chinese market and encompasses highly valuable industry evaluation and forecast for the future of the Chinese natural refrigerant market. The level of dissemination and subsequent high response rate means that the scope and detail of the responses create a clear image of a growing market in terms of natural refrigerant market.

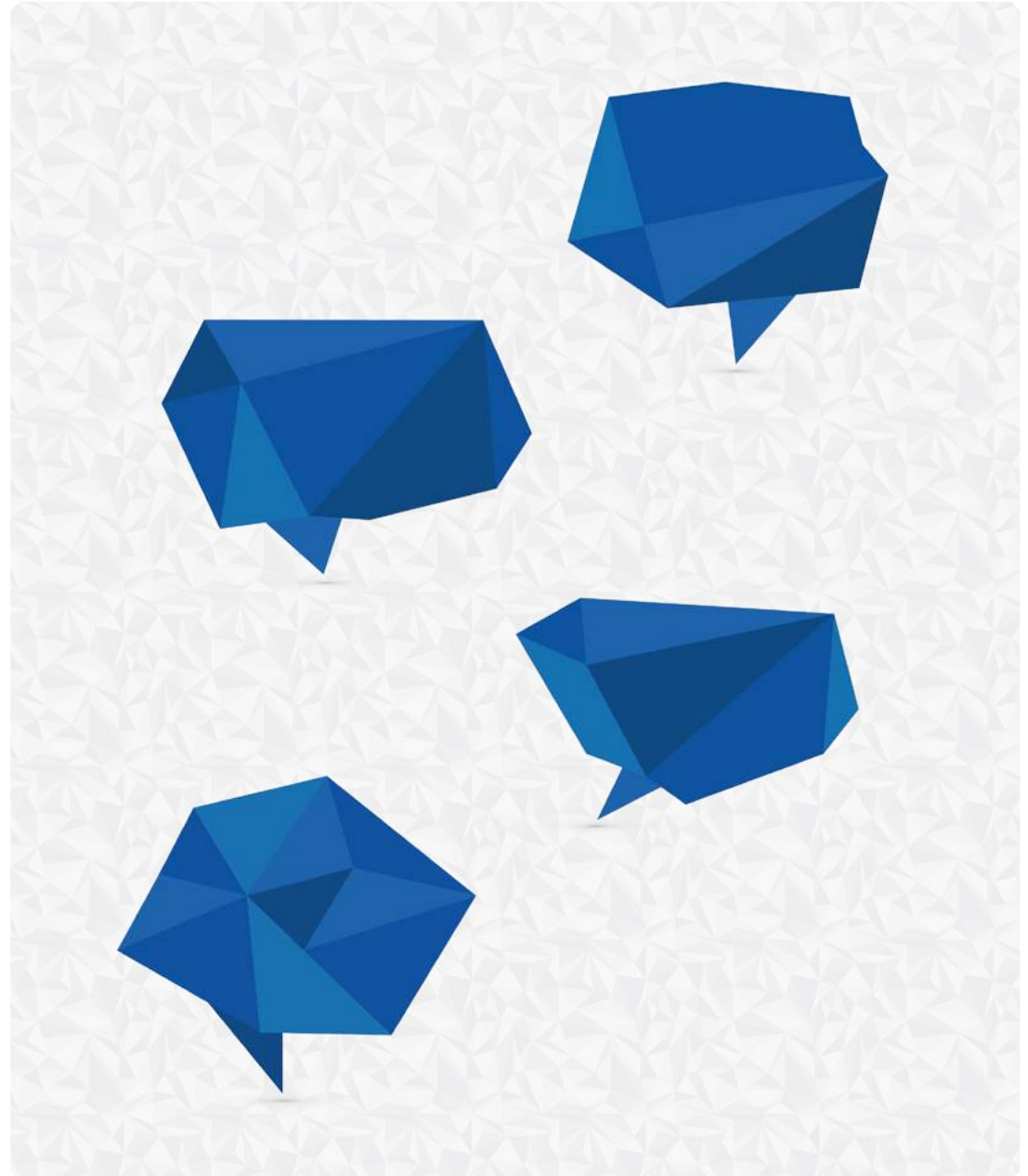

Detailed analysis of natural and non-natural refrigerant users

Within the survey itself, there was an incorporated distinction made between natural refrigerant users and non-natural refrigerant users to allow for the best understanding of the market. This dichotomy was created by analysing the respondents' answers when they provided their current refrigerant usage status. The question in the survey were divided into two groups: organisations that are already using natural refrigerants and organisations that are not currently using

natural refrigerants. Within this structure, we can easily grasp why organisations use and do not use, provide and do not provide natural refrigerant technology today, and their respective plans for the future. The survey also asks about current share and the future plan for natural refrigerants in the context of their entire R&D activities. Lastly, we identify the most important drivers for the market in natural refrigerants to grow in China in the future.

Largest ever survey of China's natural refrigerant market

The largest survey ever of the state of natural refrigerants in China came back with an impressive 1,098 unique responses from the industry,

each one full of information on the increasing role natural refrigerants are beginning to play in the Chinese HVAC&R.

Portrait of the industry – which organisations and applications are represented?

The size of the industry continues to grow and the responses from the GUIDE survey indicate the engagement of this sector with natural refrigerants. Of the 1,098 respondents to the survey, almost two-thirds are involved in system manufacturing. This was the largest group of respondents ever for such a GUIDE, which indicates a high level of scope and legitimacy, especially given the respondents are stakeholders in the

market who can incite change. The second largest respondent group were component suppliers, with 21% identifying themselves as this group, again demonstrating the large industry turnout for the GUIDE survey.

However, it is not just the industrial side of the market, which is represented. On the practical day-to-day perspectives of workers, there is a sizable portion (13.1%) of those who refer

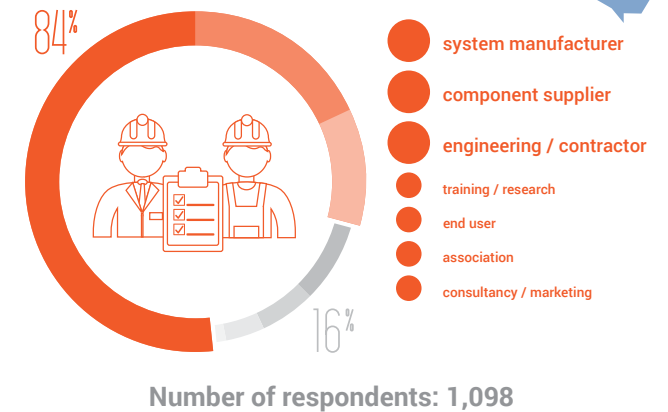

Big industry turnout for GUIDE survey

The GUIDE proved successful in getting the opinions of those who have the ability to influence change, as over half of the respondents identified themselves as system manufacturers, the highest represented group. All other types of organisations are also represented well, providing a wide range of views.

to themselves as engineers/contractors. The academic and research sphere is involved and represented, with 9.7% saying they were involved in training/research. Thoughts of those who employ these solutions were also present, with 6.4% noting they were end users. The last remaining groups were associations, for which 4.5% replied positively and 1.8% of respondents were involved in consultancy/marketing.

Overall responses detailing the size of the respondents' firms were also encouraging. In total 57.5% of respondents noted that they worked for a 'large' firm, indicating (more than 500 employees) that more of the market is being represented. The rest of the respondent profile can be broken up into 'medium' firms with 100-499 employees (25.7%) and 'small' firms' will less than 99 employees (16.8%).

The composition of respondents by sector showed a strong representation of (light) commercial and industrial applications. This can be seen by the fact that 71.7% of respondents noted

they are active in industrial and commercial air-conditioning. The next highest group was commercial refrigeration with 60.3%, followed by industrial refrigeration with 56.3%, and light commercial refrigeration with 50.3%.

In addition to this, close to half of the respondents indicated that they are active in industrial and commercial heating, 45.2% in domestic air conditioning, 35.8% in domestic refrigeration, and 33.7% in residential heating. However, it can be seen that there are areas of low activity within China with transport refrigeration and mobile air conditioning having the lowest respondents representation, with 23.3% and 22%, respectively.

As industrial and commercial are two of the most exciting application sizes for the use of natural refrigerants, this is encouraging for effectively evaluating and forecasting the HVAC&R market in China.

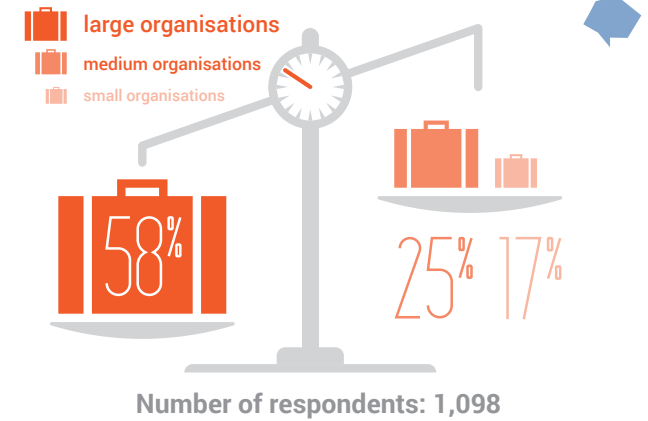

Solid representation of large market players

With over half of the respondents noting they work for a large firm, the survey is able to cover a higher percentage of the market and gauge the strongest trends.

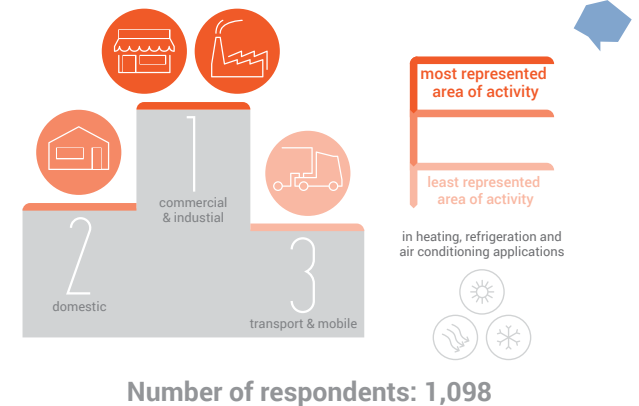

Majority of respondents active in commercial and industrial sectors

Across all three sectors, commercial and industrial heating, refrigeration & air conditioning are the most well-represented application sizes. This shows that in China, there is a strong interest and a large potential for natural refrigerants in these applications.

Effort together for safer Ammonia refrigeration

Danfoss is part of your success!

关注氨制冷系统安全 丹佛斯助您一臂之力!

Safety clearly matters, there is no higher priority. Danfoss has expertise in the “Safe of Ammonia” and we are participating the in-depth discussions and practical operations with the partners of the refrigeration industry.

就‘氨制冷的安全’这一行业焦点议题，丹佛斯愿与您分享我们在制冷系统自动化控制及行业实际应用方面的经验，期待与业内同仁并肩携手，共同提高冷库运行的安全、品质及效益。

氨亦可安

under the effective control
正确使用及有效控制

Ammonia is featured of environmental-friendly with excellent heat exchange efficiency, has been successfully and widely applied in large-scale refrigeration systems all over the world.
氨，具有鲜明的特点，是目前全球范围内大型制冷系统中采用最广泛的冷媒。合理有效地使用及管控，是确保氨制冷系统安全的关键因素之一。

1‰=100%

there is no trifle for safety
安全无小事

The safety of a refrigeration system largely depends on the design, installation and maintenance. Only the success of each part makes 100% safety possible.
制冷系统的安全与否主要取决于整个系统的设计、安装、维护以及配套的安全措施。每一个细节的优秀才能成就制冷系统100%安全无虞。



Exclusive interviews

Overview of profiles

To complement the results collected from the industry survey, exclusive interviews with esteemed academics, industry leaders and leading end users, provide a more nuanced understanding of the market through their experiences and knowledge of natural refrigerants in China. The aim is to provide the latest insights from the experts covering a wide range of different viewpoints to fully develop the natural refrigerant market picture. Interviewees were asked about their area of expertise and about how the different stakeholders are bringing natural refrigerants faster to the Chinese market.

The interviewees were partitioned into groups: government official, academics, industry leaders and leading end users. Their profiles are listed as follows.

Representative of government agency

**Foreign Economic Cooperation Office (FECO),
Ministry of Environmental Protection – Zhong
Zhifeng, Vice Chief of Division III**

Foreign Economic Cooperation Office (FECO) is an institution affiliated with the Ministry of Environmental Protection, which was founded in 1989. FECO is mandated to coordinate and manage the funds of projects in cooperation with international financial organizations and for implementation of multilateral environmental agreements (MEAs) and bilateral assistances. FECO also engages in other foreign cooperation activities in the field of environmental protection. Zhong Zhifeng graduated from Tsinghua University and holds a master degree in chemistry. In 2008, Zhong joined FECO, Ministry of Environmental Protection. He then started working in the refrigerant sector and is currently responsible for the implementation of China Room Air Conditioner HCFC Phase Out Management Plan (HPMP), Industry Commercial Refrigeration HPMP and Servicing HPMP.

Academics

Academics that have been active in natural refrigerant technology research in China for a long time provide their individual evaluation of the Chinese market for natural refrigerant development today and their predictions for the future, in terms of technology, policy and market potential.

Professor Ma Yitai – Tianjin University

Professor Ma Yitai is Tianjin University's Director of Thermal Institute and is a specialist in thermal physics engineering. His main research interests include refrigeration and heat pump energy saving technology as well as natural and other low-GWP refrigerants. He has been involved in research projects, including a CO₂ transcritical heat pump project funded by the National Natural Science Foundation of China. His most recent publication is "Natural Refrigerant, CO₂ Refrigeration and Heat Pump Circulation Principle's Research and Development (2015)".

Professor Shi Lin – Tsinghua University

Professor Shi Lin, of the Department of Thermal Engineering, focuses her research on thermal physics engineering, environmentally friendly refrigerants, the fluid thermal properties of refrigerants and nanoparticles. She is Vice Chairman of the China Energy Research Society of Thermodynamics and Engineering Professional Committee, a board member of the Chinese Society of Engineering Thermal Physics and a committee member of the IIR B1 Professional Committee.

Professor Yang Zhao – Tianjin University

Professor Yang Zhao works at Tianjin University's School of Mechanical Engineering. Her research focuses on new refrigerant heat pump technology, new gas engine heat pump technology, green refrigerant development development, as well as flame and explosion technology. She is a committee member of the IIR B1 Professional Committee, a member of the IIR Safety Expert Committee and a board member of the Chinese Society of Thermal Physics Engineering. Her publications include "Research on Improving Energy Efficiency and the Annual Distributing Structure in Electricity and Gas Consumption by Extending use of GEHP (2011)".

Wang Xunchang – China Refrigeration and Air Conditioning Association (CRAA)

Wang Xunchang is a scholar and researcher in energy efficiency in buildings and air conditioning and is also the technology advisor for China Refrigeration and Air-Conditioning Industry Association (CRAA). His research interests include ice storage air conditioning, alternative refrigerants and water source heat pumps. In his research publication he has covered the HCFC-22 phase out and air conditioning water chiller system.

Industry leaders

Industry leaders active in different applications were asked to identify their reasons for investing in natural refrigerants and provide their estimates for the future market for such equipment in China.

Panasonic – Nobuo Yoshida, General Manager

Panasonic company is globally recognised for manufacturing high quality and reliable products. In 2010, Panasonic acquired Sanyo Electric and since then have integrated Sanyo's expertise in CO₂ refrigeration and heat pump technology. The former Sanyo had developed the world's first CO₂ rotary 2-stage compression compressor, that uses the CO₂ as a refrigerant. Since the establishment of Panasonic Appliances Compressor in Dalian in 1994, the company has increased overall production capacity every year. Sales revenue has increased by 50% each year and market shares are continually expanding. Now, the company has 2000 employees, with two factories and an annual production capacity of half a million sets.

Alfa Laval – Tommy Angback, Market Unit Manager, Refrigeration

Alfa Laval is a global provider of specialised products and engineering solutions for heating, cooling and transport products in the food and beverage industry. Its products are used in power plants, aboard ships, as well as for comfort climate and refrigeration applications.

Alfa Laval has had a strong working relationship with Chinese clients since 1954 and opened an office in Hong Kong in 1982, with a Beijing office following in 1984. Alfa Laval has continued to grow and currently has eleven sales offices, eight customer service centres, four factories and wide business networks. In terms of production in China, 30% has been exported to Japan, Korea, the US and Europe.

BITZER Refrigeration Technology (China) – Stephan Luerssen, Managing Director

BITZER are global leaders in the manufacturing of refrigeration compressors, condensing units and pressure vessels, which are supplied around the world by more than 40 subsidiaries, operating in 90 different countries on five continents and cater for natural refrigerants.

In 2014, BITZER celebrated their the 20th anniversary of their production centre in China. During those twenty years the company has seen a rapid development of business in China and has established leadership in the area of retail and the frozen food processing industry, as well as air conditioning and transportation. To accommodate this growth, BITZER began expanding its facilities in Beijing in 2012.

CAREL – Frank Xia, Head of Sales & Marketing, China Region

CAREL supplies solutions and control systems for the retail market, and is committed to basic and applied research in energy savings, reduction of environmental impact and innovation in the management of systems. CAREL began their operations in China in 2000, setting up an office in Hong Kong. To meet growing demand in the Chinese market for its CAREL's services, CAREL set-up CAREL electric (Suzhou) to produce electric controls for refrigeration and air conditioning applications.

Danfoss – An Jingai, Danfoss China Standard and Approval Manager

The Danfoss group, one of Denmark's largest companies, operates in the HVAC&R and motion controls sector. Danfoss' refrigeration

and air conditioning division specialises in automatic controls, compressors and electronic sensors.

Danfoss opened their first office in China in Hong Kong in May 1994, with a second office being opened in Beijing in October 1994 and a third office in Tianjin in 1995. Danfoss has continued to grow and currently has more 2,500 employees, ten sales offices, five factories and one subsidiary factory in China. With roots bedded in China for more than 20 years now, Danfoss continues to grow rapidly and China has become its second home.

Dorin – Massimo Casini, Sales International Manager

Massimo Casini is the international sales manager of Dorin, an Italian compressor manufacturer established in 1918. Dorin extends all over the world, thanks to its commercial partnerships and internal technical-commercial personnel. Dorin entered the natural refrigeration market in 1999 with its CO₂ transcritical compressor. Today, Dorin produces around 70,000 compressors a year.

Dorin entered the Chinese market in 2008 when they opened their office in Shanghai. Dorin entered with one of the latest technologies in the compressor market and is currently the only compressor manufacturer that produces semi-hermetic CO₂ compressors in mass production.

Emerson Climate Technologies – R. Abel Gnanakumar, Director - Refrigeration Marketing, Asia

Emerson Climate Technologies is a business segment of Emerson, the world's leading provider of heating, air conditioning and refrigeration solutions for residential, industrial and commercial applications. The group combines advanced technology with their experience in engineering, design, distribution, educational and

monitoring services to provide customised, integrated climate-control solutions for customers worldwide. Emerson's market share in the Chinese cold chain market grew by 18% in 2014 and continues to grow.

Haier- Carrier – Jefferson Li, Marketing Director

Qingdao Haier-Carrier Refrigeration Equipment Co., Ltd. is a joint venture by Haier and Carrier, which started in 2001. In the past ten years the venture has developed a production factory on a global scale and is ISO9001 and UTC ACE certified. Its products include supermarket display units (more than 1000 models), compressor units (scroll, screw and centrifugal), heat exchangers (air cooled condenser and air cooler), all providing comprehensive refrigeration solutions for clients. With the support of R&D centres in Mainz, Germany, and in Shanghai, Haier-Carrier boasts R&D labs recognised by the Chinese government. Haier-Carrier have acquired patents in the following applications: D2D hot gas defrost (national patent), hybridCO₂OL (CO₂ cascade refrigeration technology), CO₂OLtec (CO₂ transcritical refrigeration technology).

Huayi Compressor Barcelona – Pedro Olalla, Sales Director

Huayi Compressor Barcelona specialises in the design, manufacture and sale of hermetic compressors and condensing units for light commercial refrigeration. The company operates under the Cubigel Compressor brand. It is owned by Huayi Compressor headquartered in China, one of the largest compressor manufacturers. It produces a wide range of compressors that are suitable for natural refrigerants like propane (R290) and isobutane (R600a) for commercial appliances. Huayi has more than 6500 employees and accounts for about 16% of the global market share.

End users

Leading end users were asked about the key drivers for their use of natural refrigerant technology, their current progress and also future plans of deploying the technology in China.

Secop – Mogens Søholm, CEO

Secop is an expert in advanced compressor technologies for various refrigerants including R600a (isobutane) for domestic, light commercial and mobile applications. The company is dedicated to creating and supporting intelligent solutions and energy efficient technologies.

Secop built a production base in Tianjin, China in 2008 to produce and assemble compressors for light commercial refrigeration and mobile air conditioning. In addition to this, Secop has a sales office located in Shanghai.

Snowman – Lin Rujie, CEO

Fujian Snowman was established in March 2000 in Fujian, China and is now a global company. Snowman manufactures commercial and industrial compressors and systems using CO₂, NH₃, hydrocarbons, water and air as a refrigerant for cooling, heating and refrigeration applications. Snowman acquired Sweden-based OPCON AC, the earliest screw compressor developer in the world. The company also owns the assets of Italian compressor brand RefComp, the owner of Swedish brand SRM. Snowman has six R&D centres located around the world; with two major manufacturing centres located in China and Italy. The manufacturer currently possesses the largest global market share in the ice machine manufacturing market and has a registered capital of ¥160 million (€23 million).

Coca-Cola – Linda Zhang, Vice President of Technical and Supply Chain in China

The Coca-Cola Company is the world's largest beverage company and one of the most recognisable brands in the world. Coca-Cola was one of the first international companies to enter China in 1979. Coca-Cola China has since developed into a company selling 140 million beverages daily. The Coca-Cola Company has set its 2020 goal to reduce the carbon footprint of “the drink in your hand” by 25% by 2020. One of the imperative actions to achieve the global goal is to use natural refrigerants in all cold-drink equipment by 2015.

METRO – Holger Guss, Construction and Engineering Senior Manager

METRO's global credentials are clear; with over 750 supermarkets across 27 countries, including more than 80 supermarkets in 56 Chinese cities. METRO prides itself on its promotion of sustainable development and environmental protection, which have been an important theme while developing the market in China.

In 2014, Metro opened their first CO₂ store in China in Weifang. This is part of a bigger overall plan as METRO GROUP aims to reduce their greenhouse gas emissions caused by refrigerants by 29% by 2020 compared to 2011 levels. This initiative includes METRO's Cash & Carry stores, which have also agreed on a programme for phasing out the use of f-gases by 2025.

Red Bull – Jürgen Brenneis, Global Purchasing Manager

Red Bull GmbH is an Austrian energy drinks provider and has been in operation since 1987. Red Bull's energy drink is currently available in more than 167 countries with 50 billion cans consumed during the company's history. In recent years, Red Bull GmbH has introduced environmentally friendly ECO-Coolers for the cooling of their drinks. ECO-coolers combine the use of R290 or R600a and incorporate other technical improvements such as energy efficient fans.

In China, Red Bull only uses hydrocarbons-based solutions for their bottle coolers. This is in line with Red Bull's aim to keep their / the environmental impact at an absolute minimum. By 2013, there were about 457,000 ECO-Coolers worldwide, representing more than 50% of Red Bull's entire fleet of cooling equipment.

Unilever – John Sears, Global Supply Chain Manager – Ice Cream

Unilever is a British-Dutch multinational consumer goods company which own brands such as Ben & Jerry's, Magnum, Lipton and Wall's. Unilever are a part of Refrigerants, Naturally!, a group who seeks to accelerate the market uptake of natural refrigerants.

Unilever is active in China, supplying hydrocarbon freezers for their products, as well as having an R&D centre located in Shanghai, which was opened in September 2009. The R&D centre has a goal to deliver even bigger 'Made in China' innovations and faster roll-outs to Unilever's key growth markets around the world by stimulating better cross-category and cross-border synergy.

About natural refrigerants

As a general differentiation, 'natural refrigerants' are substances that exist naturally in the environment, while 'non-natural refrigerants' or 'synthetic refrigerants' are man-made chemicals. The most commonly used natural refrigerants today are ammonia (NH₃, R717) carbon dioxide (CO₂, R744), and hydrocarbons (HCs), such as propane (R290), isobutane (R600a) and propylene, also known as propene (R1270).

The precision of the term 'natural refrigerants' is sometimes debated, given that, to be used as refrigerants, ammonia, carbon dioxide, and hydrocarbons also undergo an industrial purification and manufacturing process. However, today there is a well established distinction between substances whose chemical properties and safety aspects have been studied in their entirety and those fluorinated gases, which, given their chemical complexity and comparatively short period of usage, have confirmed and/or have unknown negative effects on ozone depletion, global warming and ecological safety, and therefore, are subject to continued debate.

The most commonly used natural refrigerants today are ammonia (NH₃, R717), carbon dioxide (CO₂, R744) and hydrocarbons (HCs), such as propane (R290), isobutane (R600a) and propylene, also known as propene (R1270).

Mixtures of ammonia and dimethyl ether (R723) have been developed, as well as various hydrocarbon blends with optimised performance and safety properties (isobutane/ propane; R441 etc.). Water as a refrigerant has been used especially in absorption and absorption chillers. The use of air is less common, but has been developed for deep-freezing applications.

In addition to their wide availability, their non-toxicity, non-flammability and their unbeatable environmental credentials, water and air have shifted into the focus of R&D activities. Natural refrigerants no longer in use are sulphur dioxide (SO₂) and methyl chloride (CH₃Cl).



Carbon dioxide (ODP= 0; GWP= 1)

Carbon dioxide (chemical symbol CO_2 , refrigerant designation R744) is colourless, odourless and heavier than air. With a Global Warming Potential (GWP) = 1, CO_2 is the reference value for comparing a refrigerant's direct impact on global warming.

Carbon dioxide carries an A1 safety classification (the same as most fluorocarbon refrigerants), indicating that it has low toxicity and is non-flammable. CO_2 as a refrigerant is sourced as a by-product from a number of production methods. Although it is nontoxic, if enough carbon dioxide builds up in an enclosed space, it will begin to displace oxygen. Over a certain period of time, this can cause asphyxiation of those present. With a long atmospheric lifetime, CO_2 does not lead to any byproduct formation or decay products with serious environmental impact.

When used as a refrigerant, carbon dioxide typically operates at a higher pressure than fluorocarbons and other refrigerants. While this presents some design challenges, they can be overcome in systems designed specifically to use carbon dioxide. Carbon dioxide is compatible with some, but not all, commonly used refrigeration system lubricants. In particular, it is not suited for use with polyol ester (POE) and poly vinyl ether (PVE) lubricants and it only has limited applications with poly alkaline glycol (PAG) lubricants. It is generally regarded as a cheap and easily available refrigerant.



Ammonia (ODP= 0; GWP= 0)

Ammonia (chemical symbol NH_3 , refrigerant designation R717) is a colourless gas at atmospheric pressure. With zero ozone depletion and global warming potential, as well as a short atmospheric lifetime, it does not form any by-products or decomposition products with negative environmental impact. It is compatible with some, but not all, commonly used refrigeration system lubricants. In particular, it is not suited for use with polyol ester (POE) and poly vinyl ether (PVE) lubricants, and it only has limited applications with poly alkylene glycol (PAG) lubricants.

Despite its undisputed energy efficiency benefits, the use of ammonia is restricted in certain applications and geographic regions, due to its toxicity. As a result, R717 is effectively prohibited from use inside occupied spaces but can be used in unoccupied areas or outside.

However, many advances have been made in recent years to minimise risks for human health, particularly for ammonia installations in populated areas. These advances include using ammonia in conjunction with other refrigerants, such as in secondary systems, in order to reduce and isolate an ammonia charge, using advanced safety equipment, deploying containment casings, or using ammonia absorption systems.

It is important to note that ammonia has a strong odour, making leaks easy to detect.



Hydrocarbons (ODP= 0; GWP< 4)

With zero ozone depleting characteristics and an ultra-low global warming impact, the group of hydrocarbons (HCs) does not form any by-products or decomposition products in the atmosphere.

HC refrigerants can be applied either in systems designed specifically for their use, or as replacements in a system designed for a fluorocarbon refrigerant.

This makes them a cost-competitive solution, and an optimal for developing countries. If a hydrocarbon refrigerant is to be used in a system designed for a different refrigerant, it should be noted that modifications are probably required to ensure compatibility. Lubricant compatibility and the issues associated with hydrocarbons' flammability have to be addressed. However, the greatest potential for hydrocarbon refrigerants lies in new systems.

Hydrocarbon refrigerants are flammable and, as a result, carry an A3 safety classification, which means they have a low toxicity but are in the higher range of flammability. HCs are often subject to stricter safety requirements concerning the quantities permitted in occupied spaces.

Hydrocarbon refrigerants are fully compatible with almost all lubricants commonly used in refrigeration and air conditioning systems. One major exception to this rule is lubricants containing silicone and silicate (additives which are commonly used as antifoaming agents).



Water (ODP= 0; GWP= 0)

Water (chemical symbol H₂O, refrigerant designation R718) is one of the oldest refrigerants used for refrigeration applications. Also known as dihydrogen monoxide, water or water vapour is one of the earth's most abundant elements. Water has been extensively used as a process fluid (distillation, drying processes), as a heat transfer or energy storage medium (central heating, system cooling, ice storage systems) and as a working fluid in the Rankine power generation cycle. R718 is an environmentally safe refrigerant with zero ozone depletion potential and zero global warming potential. It is odourless, colourless, nontoxic, non-flammable, non-explosive, easily available, and it is one of the cheapest refrigerants.

In refrigeration applications, water requires state-of-the-art technology. Its use as a refrigerant has been mostly limited to compression chillers with steam injection compressors, absorption systems built around a binary fluid comprised of lithium bromide as the absorbent, and adsorption systems using water as the refrigerant and the mineral zeolite as the adsorbent.

From an environmental and thermodynamic point of view, water is an ideal refrigerant for applications above 0°C. R718 has a higher latent heat of evaporation (2,270kJ/ kg) than other natural refrigerants. R718 absorbs significantly larger amounts of energy, in the form of heat, during a change of phase, from liquid to gas, without a change in temperature. An obvious limitation is the high freezing rate at atmospheric pressure. Water leads to corrosion and oxidation of many metals. Water is more reactive than other refrigerants and choosing the right materials or the R718 system during the design phase requires special attention.



Air (ODP= 0; GWP= 0)

Air (refrigerant designation R729) is a refrigerant that is environmentally benign, cheap, totally safe and nontoxic. Environmental concerns about ozone depletion, global warming, and increasingly stringent legislation have renewed the interest in alternative refrigeration technology, globally. However, the use of air-cycle refrigeration systems is not new. It was used on refrigerated cargo ships around the turn of the 20th century.

Air cycle refrigeration works on the reverse Brayton or Joule cycle. Air as a refrigerant does not undergo phase change (condensation/evaporation) at the temperature levels encountered in conventional refrigeration applications. The COP value of air is low because of its light weight, but air-cycle cooling systems can provide relatively high temperature heat recovery without the efficiency set back experienced by vapour compression systems. Air cycle units, compared to vapour-compression units, can also produce a much higher temperature difference between the hot and cold sides. As a result, very cold air can be produced for near cryogenic processes. The performance of an air cycle unit does not deteriorate as much as that of a vapour-compression unit, when operating away from its design point.

When operating in a refrigeration cycle, an air cycle unit can also produce heat at a useful temperature. Air has been used commercially for aircraft cooling for a long time. In spite of the low COP, air is used because of the specific operating conditions of aircraft (e.g., availability of compressed air and ram effect) and stringent specifications (e.g., low weight, small size, absolute safety, zero toxicity, etc.). Air has also been used as a refrigerant for residential and automobile air conditioning and cooling. In some refrigeration plants, air is used in the quick freezing of food products.



Refrigerants	Ammonia	Carbon dioxide	Propane	Isobutane	Propylene	Water	Air
Refrigerants number	R717	R744	R290	R600a	R1270	R718	R729
chemical formula	NH ₃	CO ₂	C ₃ H ₈	C ₄ H ₁₀	C ₃ H ₆	H ₂ O	-
GWP (100 years)	0	1	3.3	4	1.8	0	0
ODP	0	0	0	0	0	0	0
normal boiling points (°C)	-33.3	-78	-42.1	-11.8	-48	100	-192.97
critical temperature (°C)	132.4	31.4	96.7	134.7	91	373.9	-
critical pressure (bar)	114.2	73.8	42.5	36.48	46.1	217.7	-
Safety group	B2	A1	A3	A3	A3	A1	-
molecular weight (g/mol)	17.03	44.0	44.1	58.12	42.08	18	28.97



Application of natural refrigerants in China TODAY: market, technology & policy overview

Introduction

China's current natural refrigerant market is one full of intrigue, with solid foundations already being laid for the future. This section will serve as a signpost to the significant developments ongoing in China's natural refrigerants market, including subtle shift in market trends and incoming national and global policies on HFCs and HCFCs. The interviews with academics, industry experts and end users provide insights about how they view the current business and policy climate and the exciting new technological advances they see on the horizon.

Firstly, the GUIDE will provide an in-depth analysis of China's current natural refrigerants market, noting the profile of the industry, stating where current optimism is, where potential problems lie and which solutions could come to the forefront. These are complemented with interviews of leading stakeholders and the results of the largest survey ever conducted on China's natural refrigerant market.

Secondly, with all these details it is easy to not see the forest for the trees, so a clear illustration of the current landscape of China's natural refrigerants market will be presented in the form of the GUIDE's 'ecosystems' section. This portrait will serve as an easy-to-understand go-to reference for those interested in which applications natural refrigerants are already used within China.

Thirdly, the GUIDE presents the 'future' section, which will look at businesses' plans for the future including which refrigerants look set to soar and the forecast for China's HVAC&R sector. This section will also present the thoughts and research of leading academics as well as the concerns and solutions end users envisage for the future.

Market and technology trends

Chinese natural refrigerant market geared up for continued growth

As a country with 1.3 billion people and the second largest economy in the world, there is an increasing concern within China over air pollution. This concern has led the Chinese government to make a big decision and to revise the Environmental Protection Law for the first time in 25 years - which became active in 2015. This change in legislation is in addition to the increased emphasis on energy efficiency and technological development within the industry. The focus is to assist in maintaining the Chinese industry's competitive edge in the global economy, which could lead directly to a faster development and adoption of natural refrigerant-based technology, by both the industry and end users.

In the HVAC&R sphere, China has taken steps to limit greenhouse gas emissions. Recent developments include reversing its former position and agreeing to support a phasedown of HFCs. These strong government actions, coupled with the increased emphasis on energy efficiency and technology development in the HVAC&R industry, to maintain China's competitive edge in the world market, could lead to a much greater use of natural refrigerants in China, both by manufac-

turers and end users. Thus far, China has been slow to leave the gate in the race for the adoption of natural refrigerants compared with markets in Europe, Japan and even North America. However the nation's delayed start isn't necessarily indicative of the future trends.

2014 was a very important year for the development of the natural refrigerants market in China. With increased attention paid to CO₂ as a refrigerant in heat pumps, industrial and commercial application, and R290 in room air conditioning, the market for 2015 is set-up to be one that develops quickly. In addition to this, the application of natural refrigerants has been expanded from their traditional use in industrial and commercial applications, to light commercial and residential heating, air conditioning and refrigeration equipment. The current market trends indicate exciting developments in China in the coming years.

From the survey, the market for natural refrigerants is still developing in China, however, the industry is well informed about natural refrigerants and believes that the potential in the market will be huge in the future. Nevertheless, there are

barriers to this growth in the current market paradigm, which are addressed in the industry survey and in the interviews, and these barriers will have to be taken into consideration to ensure a prosperous future for natural refrigerants within China.

For the Chinese market, going natural makes economic sense. The government is already well aware that the increased efficiency which natural refrigerants offer is an important way to help the economy's continued growth in a sustainable manner. The Chinese Government has noted that future technology developments should focus on safety, high efficiency and reduced carbon emissions, of which all natural refrigerants address.

Moreover, the government is putting increased emphasis on maintaining a competitive edge in the world market by improving energy efficiency and keeping up with technology advancements around the globe. This means that as China's export markets - particularly Europe and North America - adopt natural refrigerants, the Chinese industry will follow this trend in production.

5 key and current market trends in China

AMMONIA IN INDUSTRIAL APPLICATIONS AND HYDROCARBONS IN RESIDENTIAL REFRIGERATION ARE ALREADY ESTABLISHED SOLUTIONS

Currently, the established markets for natural refrigerants in China are the use of ammonia in industrial refrigeration and the use of hydrocarbons in residential refrigeration. The GUIDE survey confirmed that these two technologies are the standards in the Chinese market and will continue to grow.

Ammonia has been used in industrial applications for more than 60 years in China and is currently experiencing further

growth due to the rapid rise of large-scale cold storage in China. Already, ammonia has been applied widely in industrial processing, agricultural production process, power plants, sports facilities and cold storages.

The market share for the use of hydrocarbons in new domestic refrigeration is estimated to be already close to 100% in China. Since the introduction of the equipment by a Chinese

manufacturer, the technology has quickly expanded amongst other manufacturers. The market also continues to grow as the demand for domestic refrigerators increases, due to the raising of living standards in China. Like ammonia in industrial refrigeration, this trend is already well defined and will continue in the future.

CO₂: CROSS-APPLICATION POTENTIAL AS A REFRIGERANT

In the last few years, CO₂ as a refrigerant has made the largest technological leaps in China, and as a result, its usage is beginning to be introduced to various applications, including heat pumps, light commercial refrigeration, commercial refrigeration and industrial refrigeration. This cross-application is confirmed by the GUIDE survey, which shows that the respondents see CO₂ as having the largest future potential in

various applications; from industrial application, to commercial, light commercial and even residential applications.

Currently, we can already see the use of CO₂ for refrigeration in supermarkets, food processing, sport facilities, data centres, as well as for heating and cooling in public buildings and households.

Although CO₂ technology in China has made great progress in the last few years, steps are still yet to be taken in the development of CO₂ transcritical systems. Currently most applications in industrial and commercial refrigeration use CO₂ as a secondary coolant or as a low-stage refrigerant in cascade systems.

HYDROCARBONS IN RAC: GREATEST PROGRESS BUT STILL DEVELOPING

The use of hydrocarbons in room air conditioning (RAC) has made significant progress in recent years, in particular in 2014. The technological progress was achieved with the support of international stakeholders in addition to the Chinese government's policy support and subsidies.

This level of technological advancement and conversion does not, however, necessarily lead to the instant commercialisa-

tion of the equipment. As the GUIDE survey pointed out, R290 in RAC is not viewed as the application with the best market and policy climate in China, compared to other applications. This is because there still remain necessary improvements in the level of training, not only in the production process but also training for engineers in installation and maintenance and for the general public, when using the products in order

to address the flammability of hydrocarbons. From the governmental side, the development of standards and regulations on the production and installation process would be the key for this market to develop.

TRAINING: CRUCIAL PROCESS WITH LONG TERM INVESTMENT

Although natural refrigerant-based technology has been developing quickly in China, the technology is still new to some applications. This raises the question of the urgent and long-term need for the training of personnel that are able to handle and manage the new technology safely. The increased attention regarding safety in the work process today has made the government and the industry pay more attention to

training in China.

However, this process is a long-term investment and the attention of government would only play the role to drive this investment. As mentioned previously, the training of personnel is necessary not only within the production process, but also in installation, and maintenance. Thus, the quality and

level of training is as important as the awareness of this task. As such, training is one of the most important tasks for the Chinese industry today and will become even more important in the future when new technologies are expanded into new applications.

END USERS: KEY DRIVER FOR THE MARKET

End users can be very important drivers for certain applications to grow, such as commercial and light commercial refrigeration. However, the role end users play in shaping the market in China is not as prevalent as in other markets, such as Europe, Japan and the U.S. Moreover, it is the international end users, rather than local ones that are driving the change towards natural refrigerants. The major reason is major reason is that public concern the public concern over environmental protection in China has only developed as of late. As a result, end users have not found it crucial to incorporate

environmental protection into their marketing and branding strategy as Europe and North America have with their adoption of the corporate social responsibility culture.

But with increased public concern over environmental protection in China due to air pollution in some parts of the country, more end users will begin to become aware of the need to invest in natural refrigerant-based solutions in order to enhance the value of their brands, as we can already see in other regions.

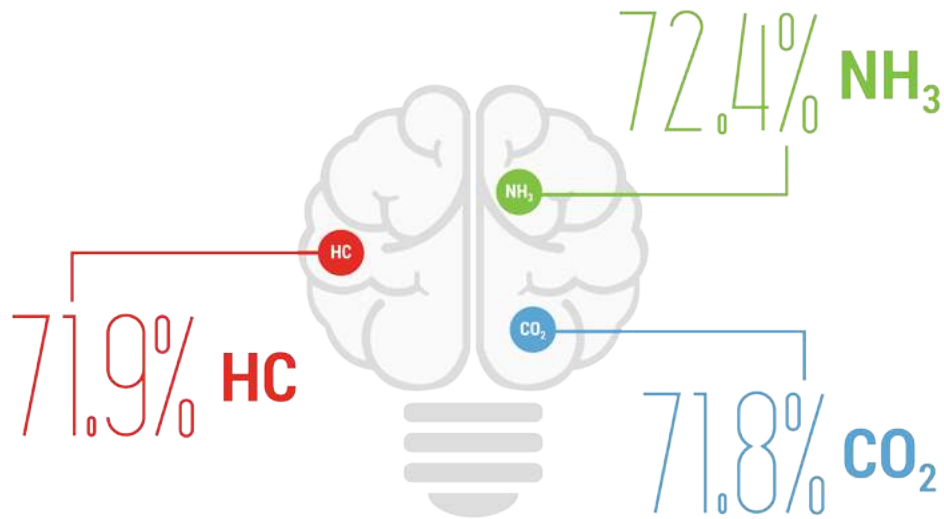

Number of respondents: 892

High level of familiarity with CO₂, hydrocarbons and ammonia

The three major natural refrigerants - carbon dioxide, ammonia and hydrocarbons - all share a high level of familiarity with 71.8% of respondents noting they are either 'familiar' or 'very familiar' with carbon dioxide, 72.4% with ammonia and 71.6% with hydrocarbons. Each respondent was allowed to choose more than one refrigerant.

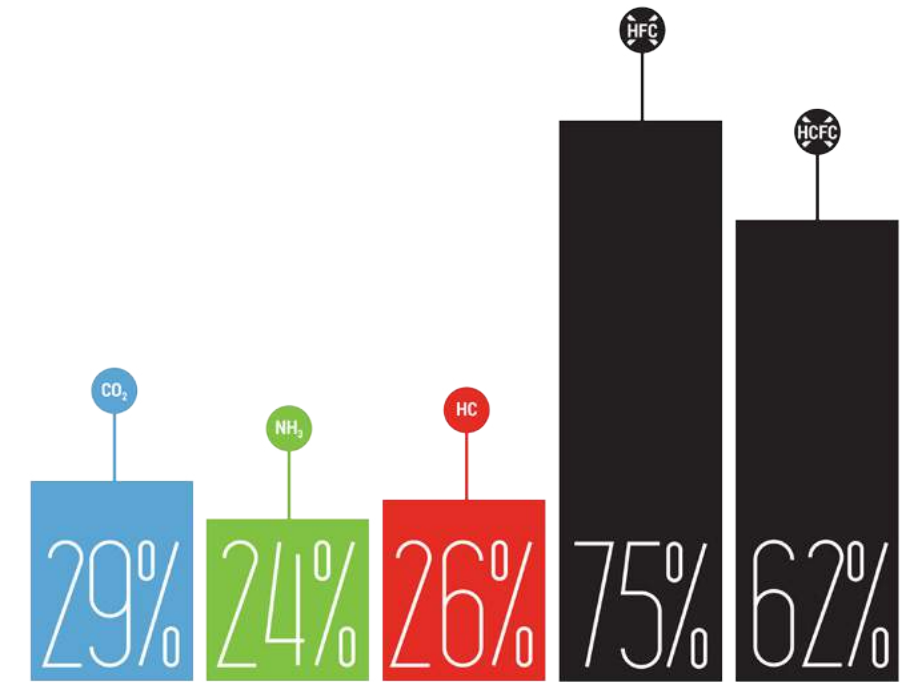

Number of respondents: 1,085

Considerable share of respondents already use natural refrigerants

Natural refrigerants in China today already have an established share across different sectors. Carbon dioxide is currently seen as the most popular, with 29% of respondents already using it as a refrigerant. CO₂ is followed by hydrocarbons in terms of popularity and use, with 26% of respondents noting they use this refrigerant and out of the three major refrigerants, ammonia currently has the lowest use with 24%, however, this is due to the limited application areas for ammonia compared to hydrocarbons and CO₂.

Nevertheless, HFCs (75%) and HCFCs (62%) remain the dominant refrigerants in China today. This usage is expected to diminish in the upcoming years; with China's plan to phase down HCFCs starting from 2015 with an aim to have them completely phased-out by 2030.

What are the drivers and barriers for natural refrigerants in China?

What are the drivers – current natural refrigerant users:

Companies currently working with natural refrigerant technology consider safety, followed by reliability, as the major reasons for providing such products and services. This goes hand-in-hand with the growing importance put on improving safety in China, especially in industrial refrigeration from 2013.

Reflecting the increased focus on environmental responsibility, the environmental impact of natural refrigerant technologies was ranked as highly important. In view of the national and global trends towards limiting the use of high-GWP refrigerants and promoting energy efficiency low carbon technologies, the legislation plays an important role for natural refrigerant technology providers.



What are the barriers – current non-natural refrigerant users:

For those who currently do not work with natural refrigerants, the major concern for their implementation is safety, followed by reliability and efficiency & performance. These three factors also ranked the highest when respondents were asked about the reasons for providing natural refrigerant solutions. Thus, safety, reliability and efficiency & performance of natural refrigerant technologies need to be better conveyed towards current non-natural refrigerant products providers.

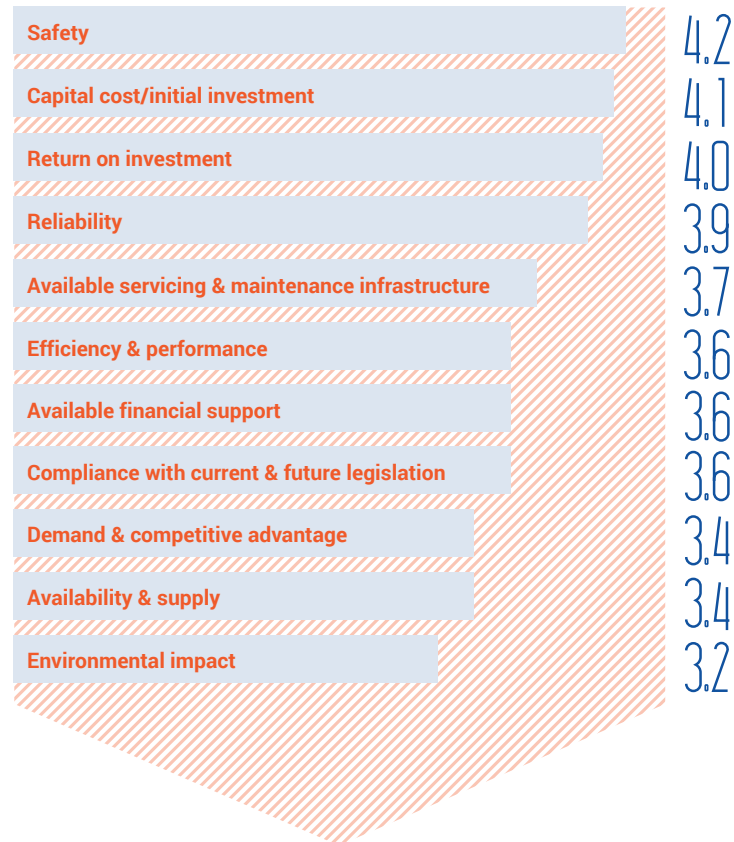

Number of respondents: 498



Exclusive interviews - Market trends & drivers

WHAT DO YOU THINK IS THE MAJOR MARKET TREND IN REGARD TO NATURAL REFRIGERANTS IN CHINA TODAY?

Professor Ma Yitai, Tianjin University:

The traditional natural refrigerant in China is ammonia, which is mainly used in large volume in industrial refrigeration and in cold storage, as well as in meat and seafood processing facilities. Most cold storages use an ammonia direct evaporating system. In order to ensure further safety in cold storages and cold chain processing facilities, the trend of using CO₂/NH₃ cascade systems is developing strongly in China. For R290 in room air conditioning, there are already a number of production lines converted to this refrigerant, with the government stating in April 2014 that they will provide subsidies to the production and sale of R290 RACs

Professor Shi Lin, Tsinghua University:

In 2014, CO₂ had the most stable growth in the Chinese natural refrigerant market. According to statistics, the application of CO₂ in cold storage is increasing. Some research institutions and companies in China are gradually developing CO₂ heat pump water heater products. In the Mobile Air Conditioning (MAC) area, Chinese companies and organisations are discussing with EU organisations about the potential of CO₂ in such systems. For NH₃, as some accidents have occurred in China, its development has been prevented in potential NH₃ applications. Hydrocarbons still have a dominant position in domestic fridges and its application in small volume RAC is ready to be promoted to the market. Already, key technical standards and related regulations have been developed to ready the market developed and related regulations are ready.

Wang Xunchang, China Refrigeration and Air Conditioning Association (CRAA):

After 2014, the trend for natural refrigerants in industrial, commercial and residential application in China is becoming clearer. The speed of development depends on the government policy and technology transfers from European, American and Japanese companies.

Professor Yang Zhao, Tianjin University:

R290 is entering a good development phase and many Chinese manufacturers already have the ability to commercially use R290 as a refrigerant in RAC.



HOW DO YOU EVALUATE THE MARKET FOR NATURAL REFRIGERANT TECHNOLOGY IN CHINA UNTIL TODAY IN YOUR AREA OF EXPERTISE?

Nobuo Yoshida, Panasonic:

Panasonic's area of expertise is in CO₂ compressors used in heat pumps, small-scale refrigeration and cooling applications. Currently in this market, CO₂ technology and R&D is still in its infancy in China. Panasonic is one of the few compressor manufacturers that mass produces CO₂ compressors in China. At present, our CO₂ compressors are mainly being sold in Japan. In China, we are currently providing CO₂ compressors for testing to some clients; these are mainly applied in heat pump water heaters and small refrigeration applications. Since CO₂ as a refrigerant has significant differences in both physical features and controlling logic, our clients are still in the R&D phase. Recently, however, due to an increase in client enquiries, we can tell that there is a growing interest in CO₂ technology and it seems the development phase is being transformed to the practice stage.

Tommy Angback, Alfa Laval:

We have had a backlash towards synthetic refrigerants from ammonia in the industrial refrigeration field after the severe accidents in recent years. This is hopefully resulting in better regulation of approved components for high-pressure systems with ammonia. We also see a bigger market for indirect NH₃ systems with brine or CO₂ as a secondary refrigerant.

Massimo Casini, Dorin:

Through promotion of CO₂ in refrigeration equipment, the allocation of subsidies would help incentivise CO₂ heat pump water heater technology. For ammonia as a refrigerant, the standardisation and training of technicians can increase the application of ammonia. To improve hydrocarbon risk assessment in limited operation and maintenance environment, there should be an analysis of an incident probability tree.

Stephan Luerssen, BITZER:

Today in China, natural refrigerant technology is mainly applied in industrial refrigeration, which uses ammonia. In the air conditioning and commercial refrigeration segment, HFCs are still used in most applications. From the end user point of view, the benefits of natural refrigerants are not yet well understood and not among the key decision criteria for projects.

Jefferson Li, Haier-Carrier:

In China, we have the expertise for CO₂ solution for commercial refrigeration and although this application is still in its infancy in China, the market is heading in a positive direction. We can see there is an increasing number of our customers who are exploring the option of CO₂ systems for their supermarkets and cold storages.

An Jingai, Danfoss:

Danfoss is ready to supply R290 and R600a technology and components in different applications. Since China's safety standard BG9237 is not renewed yet, the Chinese market is still behind other countries. Component supply and technology in China is ready and waiting as soon as the regulation is renewed. The key factor for CO₂ and NH₃ remains training in safety.

In recent years, CO₂ has become an increasingly important refrigerant in a number of applications. From an environmental and safety point of view, CO₂ is one of the few sustainable refrigerants for supermarket systems. However, CO₂ is not a drop-in replacement for existing refrigerants, and its suitability for each application should be evaluated against total equivalent warming impact (TEWI) and life-time cost.

**Lin Rujie,
Snowman:**

Since its establishment, Snowman has been committed to the development of natural refrigerant technology. Until today, we obtained strong competitiveness in application fields such as food, chemical industry, ice making, cold chain, pharmaceutical, and industrial heat pumps with system design, contracting, maintenance and after-service of systems. In recent years, we put emphasis on screw compressor development using natural refrigerants to be applied in different fields.

In today's industrial refrigeration market, NH₃ is still the most popular solution and has been applied in various refrigeration projects that have been operated safely for many years and we expect this to continue to be the case. In recent years, we have also developed CO₂ refrigeration technology for secondary and cascade systems in industrial refrigeration. This technology has been adopted in some projects and we will increase the promotion of CO₂ technology from now.

**R. Abel Gnanakumar,
Emerson Climate Technologies:**

On September 15th 2014, during the International Ozone Layer Protection Day, the Chinese Government announced the closure of five HCFC production lines, which represents the earnestness of the Government's determination to reduce the use of HCFCs. 2015 will also be an important year, as China will reduce HCFC production by 10%, a trend that will continue until 2030. These developments will create a huge challenge to find a replacement refrigerant.

In addition to this, the 1997 Kyoto Protocol aims to curb all greenhouse gases, therefore natural refrigerants like CO₂, NH₃, and hydrocarbons, which have zero ODP and low GWP have received more focus in the industry, and are going to be promising alternative refrigerants. Comparative research and test projects have been launched recently, however, due to the higher cost of the new generation of products, and the lack of public awareness and policy support, it will need time for transition.

**Frank Xia,
Carel:**

We consider China the world's largest refrigeration and air conditioning market. In the last few years, China has already started to jump from synthetic refrigerants to more environmentally friendly, low-GWP alternatives such as CO₂. International players and domestic companies have already started to explore the benefits and the opportunities coming from the introduction of this technology i.e. by investing in research, laboratory and prototype units. However, our assessment of the current market is that it seems to be still in an early stage. Barriers, such as initial investment costs and a lack of knowledge remain.



WHY HAVE YOU DECIDED TO INVEST IN NATURAL REFRIGERANT TECHNOLOGY IN CHINA?

Jefferson Li, Haier-Carrier:

CO₂ is a natural refrigerant that has zero ODP and a GWP that is practically zero and it is also 10% more energy efficient than conventional systems. CO₂ as a refrigerant has been widely accepted by food retailers around the world, with a proven track record in Europe over the last 10 years. Therefore, Haier-Carrier has a lot of experience in CO₂ systems, with our CO₂ solutions being installed in nearly 2,000 supermarkets in Europe.

Over the last few years, we have been training our design, installation and service teams in China who are now prepared to support customers in making the switch to CO₂ solutions to help reduce their environmental impact.

Tommy Angback, Alfa Laval:

We have expertise in supplying heat exchangers for air conditioning and refrigeration to achieve high energy efficiency of systems. A natural step is to promote this technology with additional features to fit natural refrigerants.

Lin Rujie, Snowman:

Snowman positively responds to the requirements of the international community and the Chinese government's plans to phase-out refrigerants that have a high negative environmental impact. We develop our products with a focus on natural refrigerants-based technology to increase its share in the market. Choosing natural refrigerants means they will not be phased-out and also means they do not create potential problems for end users in the future if they have to convert or rebuild projects. Due to these reasons, Snowman will lead the drive for natural refrigerant-based technology to be applied in different application fields in China.

John Sears, Unilever:

Our core purpose at Unilever is 'making sustainable living commonplace', so investing in natural refrigerants is a part of Unilever's global policy and as such, China is not treated any different than other countries. In fact, implementation in China is perhaps easier due to the capabilities of the manufacturers there.

Nobuo Yoshida, Panasonic:

Panasonic is a global leader in CO₂ technology and has had CO₂ products on the market for many years. We have applied this technology widely, from freezing to refrigeration and water heaters, and have used Japan as the testing ground to understand the market better before providing for the bigger Chinese market. Based on our findings we have decided to invest in natural refrigerant technology for China. In 2012, we began mass-producing CO₂ hermetic rotor compressors for residential heat pump water heaters, vending machines, and refrigeration equipment.

R. Abel Gnanakumar, Emerson Climate Technologies:

Along with the implementation of the Montreal and Kyoto protocols and the growth of China's economy, the increasing focus is being paid to global environmental protection. These factors mean that the application of the refrigerants with zero ODP and low GWP will become the future trend. The expected replacement of refrigerants will bring a great challenge for the related industrial chain in the industry and succeeding in this transition often relies on reacting well to difficult issues, or better yet, anticipating the next hurdles before they arrive.

Stephan Luerssen, BITZER:

When it comes to compressors, BITZER is the leading research, design and manufacturing company in the world, and this includes natural refrigerant technology. Currently, BITZER has over 43,000 CO₂ compressors installed across the world. We are driving our technology and applications towards natural refrigerants, not only because BITZER has the technological know-how and advanced expertise in this area, but because we believe it is BITZER's responsibility to protect the environment. This same concept also applied when we decided to invest in natural refrigerant-based technology in China.

Massimo Casini, Dorin:

We are convinced that Chinese policy will help the local industry to develop systems and applications with CO₂ for both the domestic and export markets and our investment in China also reflects our global strategy; as we invest in CO₂ in other countries.



FROM AN END USER PERSPECTIVE, WHAT ARE THE KEY DRIVERS FOR YOU TO INVEST IN NATURAL REFRIGERANT TECHNOLOGY IN CHINA?

Linda Zhang, The Coca-Cola Company:

At Coca-Cola, we believe that we can make a difference and that is why the company has committed to bold 2020 Sustainability Goals, which focus on water stewardship, climate protection, packaging and agriculture. Reducing the carbon footprint of 'the drink in your hand' by 25% through our full end-to-end value chain by 2020 is Coca-Cola's Goal for Climate Change. One of the imperative actions to achieve the goal is to use natural refrigerant fluids to phase out the use of HFCs in cold drink equipment. Our goal is for newly purchased cold drink equipment to be 100% HFC-free by 2015 globally.

With an investment of more than \$100 million in research and commercialisation initiatives, and an ongoing, ten-year commitment, our CO₂-powered coolers help pave the way to a greener future.

In China, we started the HFC-free refrigeration project in 2005 and have been working with Sanden in developing the CO₂ compressors in Shanghai since 2010. Today, we have tested and certified their CO₂ compressors with small and medium cooling capacity, which is compatible with our single and double door coolers, vending

machines and fountain equipment. Starting from 2015, more than 90% of cold drink equipment that we purchase in China will be HFC-free models certified by The Coca-Cola Company.

Holger Guss, Metro:

Metro Cash & Carry, as a global operating wholesale organisation, is aware of its responsibility to act in a sustainable manner. Hence we follow a clear policy as regards the use of refrigerants, which exceeds the national minimum standards in terms of environmental impact. We therefore go for the implementation of natural refrigerants in China, as well. Here our focus is initially set on CO₂ applications in the low temperature range.

WHICH COMPONENT / SYSTEM OR OTHER INNOVATION HAVE YOU AND YOUR CHINESE PEERS WORKED ON IN THE LAST FEW YEARS THAT PROMISES HIGH INNOVATION POTENTIAL?

Professor Ma Yitai, Tianjin University:

I have always believed that CO₂ is an important working fluid in the refrigeration and heat pump industry. However, when CO₂ is used in a simple refrigeration cycle through a throttle valve, the system energy efficiency is lower and the compressor discharge temperature is high. Through the carbon dioxide system cycle analysis, we know that the energy efficiency can be improved in two aspects: reducing throttle loss and enhancing heat transfer. Our research team has been exploring expanders to replace the throttle valve technology in CO₂ refrigeration cycle since 1997. We have independently designed and developed CO₂ expanders to replace the throttle valve, increasing energy efficiency by more than 50%.

In addition to this, taking into account the prospect of CO₂ being used in a larger capacity in future, we carry out theoretical research and experimental studies in special heat exchangers for a CO₂ system, particularly for a variety of shell and tube evaporators.

Professor Shi Lin, Tsinghua University:

Among the key research areas are the thermophysical properties and transport properties of natural refrigerants and its mixtures, working fluids for moderate and high-temperature heat pumps and the performance of micro channel heat exchangers.

Professor Yang Zhao, Tianjin University:

The research focus is especially on reducing the dependency on electricity and instead using clean and renewable energy technology.



FROM AN END USER PERSPECTIVE, ARE THERE DIFFERENCES IN DEPLOYING NATURAL REFRIGERANTS TECHNOLOGY IN CHINA AS COMPARED TO OTHER COUNTRIES?

Holger Guss, Metro:

Our sustainability policy is valid globally. Due to this, China is no different for us than are other countries. The aim is to minimise the environmental impact caused by our business globally. From a technical point of view the availability of competent and skilled suppliers has to be taken into account. Besides this, China stretches across several different climate zones, which needs to be considered in the selection and design of plant concepts.

Linda Zhang, The Coca-Cola Company:

CO₂ technology is our HFC-free technology of choice. In China, we are fully aligned with our overall global direction and have been focusing on CO₂ technology for the majority of the cold drink equipment.



HOW CAN NATURAL REFRIGERANT TECHNOLOGY BECOME MORE AFFORDABLE IN CHINA?

Professor Ma Yitai, Tianjin University:

Natural refrigerant-based technology is still in its early development phase. China has a lack of Chinese brands and key components have to be imported so the cost is going up. By developing technology and further development of the commercialisation of products, I believe in the near future the cost will decrease gradually. For instance, Yantai Moon have developed their own CO₂ screw compressors, the price of which is not different from those based on conventional refrigerants. Except the need to strengthen safety protection, the price difference for R290 heat exchangers is not large.

Wang Xunchang, China Refrigeration and Air Conditioning Association (CRAA):

For natural refrigerants, the price is not about the refrigerants itself. It is more about when China can really master natural refrigerant technology in different applications. If China can make the progress sooner rather than later, then the price will fall earlier and applications will be widely used sooner.

Professor Yang Zhao, Tianjin University:

Compared with blended refrigerants, natural refrigerants do not require (or very little) patent licensing fees. As a result, natural refrigerants have an advantage in the cost of the refrigerants themselves. In addition to this, using mineral lubricating oils is cheaper than using ester oil but the real costs come in production line conversion. The best way to reduce overall technology cost is to enforce international co-operations to optimise resource distribution.

IN WHICH APPLICATIONS CAN R290 BE APPLIED AND WHAT ARE THE KEY FEATURES OF SUCH EQUIPMENT?

Lin Rujie, Snowman:

Snowman focuses on environmentally friendly technology with comprehensive solutions. Refcomp recently developed the first R290 screw compressor to be applied in central air conditioning, high temperature refrigeration, supermarket cabinets, process air conditioning, daily hot water provision, heat pump for space heating: traditionally areas where R290 is not used. R290 screw compressors are safe, reliable, intelligent and have a high energy efficiency. However, elsewhere in the market, R290 is typically used in residential room air conditioning.

Therefore, the technology Snowman-Refcomp possesses can fill in the gaps for applications in central air conditioning and other areas.

Policy trends

China's changing stance in global talks on HFCs

National and international policy plays an important role in driving the decisions of the Chinese industry and end users away from HFCs and HCFCs. Before 2013, China had been a strong opponent of a global reduction in HFC production and consumption under the Montreal Protocol, an international legally binding treaty with a mandate to phase out ozone depleting substances (ODS). Following the rising levels of HFCs as replacement to ODS and the growing momentum on reduction of HFCs built across different regions, China had relaxed its strong opposition and agreed to move towards a global phase down of HFCs. In June 2013, Chinese President Xi and US President Obama agreed to work together to phase down the production and consumption of HFCs. The agreement was a historic

step towards building a global consensus for an international agreement to phase down these potent climate changing gases under the Montreal Protocol. In November 2014, President Xi and President Obama reconvened to set out a plan to cut greenhouse gases. The deal includes a new commitment by China to peak carbon emissions by 2030 in addition to obtaining 20% of its energy from non-fossil fuels by 2030.

Results from the survey among close to 1,100 experts also indicate that the industry recognises that a future agreement on a global HFC phase down would have a great impact on the investment decisions and the move towards natural refrigerants.

Opportunity to leapfrog HFCs in China's HCFC phase-out

As a signatory to the Montreal Protocol, China has agreed to gradually phase out the production and consumption of HCFCs by 97.5% by 2030, while allowing the remaining 2.5% for servicing of existing refrigeration and air conditioning systems during the period between 2030 and

2040. Achieving the HCFC phase out compliance targets will be a significant task that requires the involvement of a multitude of industries and sectors, but also presents opportunities to the market to replace HCFCs with natural refrigerants.

1 National legislation restricting the use of HFCs

2 Global agreement on HFC phase-down

3 Standards to allow wider use of natural refrigerants

4 Financial incentives

5 Awareness raising

6 Increased availability of training

7 Voluntary initiatives

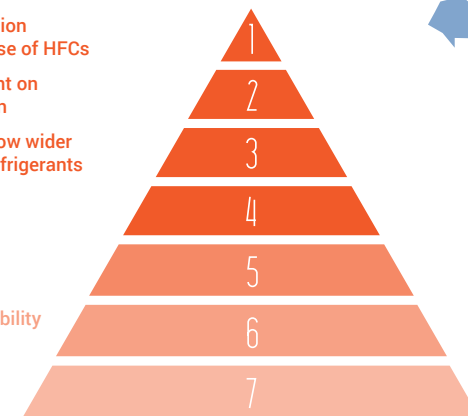

Number of respondents: 587

National and international policy seen as key drivers for natural refrigerants

Industry representatives were asked what is needed to accelerate the move towards natural refrigerants. The survey results indicate that regulations and standards at national and international level are necessary for the Chinese industry to move away from HCFCs and high GWP HFCs. On the other side, voluntary initiatives are not considered to have a far-reaching impact on the Chinese industry.

In order to help China freeze the production and consumption of HCFCs in 2013 (baseline 2009-2010) and achieve the first reduction step by 10% by 2015, funding was provided by the Multilateral Fund of the Montreal Protocol. As part of the first stage of the HCFC phase out management plan, 40 production lines for air conditioning and compressors, as well as 50 manufacturing lines for commercial and industrial refrigeration equipment, are being converted from R22. Additional activities to support the switch to climate-friendly alternatives such as hydrocarbons, CO₂ and ammonia include training and awareness raising, capacity building, monitoring and verification. Moreover, the Chinese Ministry of Environmental Protection provides technical assistance to study replacement technologies, including those using natural refrigeration, and to revise standards for new technologies. Starting in 2015, the government will take additional measures to promote heat pump technologies and CO₂ technology

Short-term target to reduce HFCs by 280 million t CO₂eq

The industry survey found that national legislation on the use of HFCs / HCFCs is amongst the strongest drivers to shift to natural refrigerants. Besides the long-term phase out target for HCFCs, in May 2014 China's State Council announced a short-term target to reduce emissions of HFCs by 280 million tonnes of CO₂ equivalent by 2015, as part of its 2014-2015 Energy Conservation, Emissions Reduction and Low Carbon Development Action Plan. In addition, China announced that in its next five-year plan starting,

in supermarkets. In preparation for the second stage of the HCFC phase out plan, the government is conducting a survey to gather information on the cold chain industry.

In addition to conversion of equipment manufacturing facilities, China has agreed to close and dismantle the production of HCFCs for uses controlled under the Montreal Protocol, by 2030. The country has agreed to ensure that any HCFC plants that will receive funding do not switch to producing HCFCs as industrial feedstock; a use not controlled by the Montreal Protocol. The latest data shows that China produces 92% of the total HCFC production of developing countries. China's HCFCs are supplied to the world's refrigeration, air conditioning and foam manufacturing sectors, also used as solvents and to some extent for fire protection equipment and the sterilisation of medical devices. The phase-out of HCFC production in China is therefore fundamental to ensure the global HCFC phase out.

in 2016, it will for the first time include controls of CO₂ emissions by an absolute quota. The Action Plan supports the installation of energy-saving technologies in industry, construction, transportation and public facilities, and encourages the reduction of HFC emissions through the accelerated destruction of these gases and replacement with alternative refrigerants, used in refrigeration and air-conditioning.

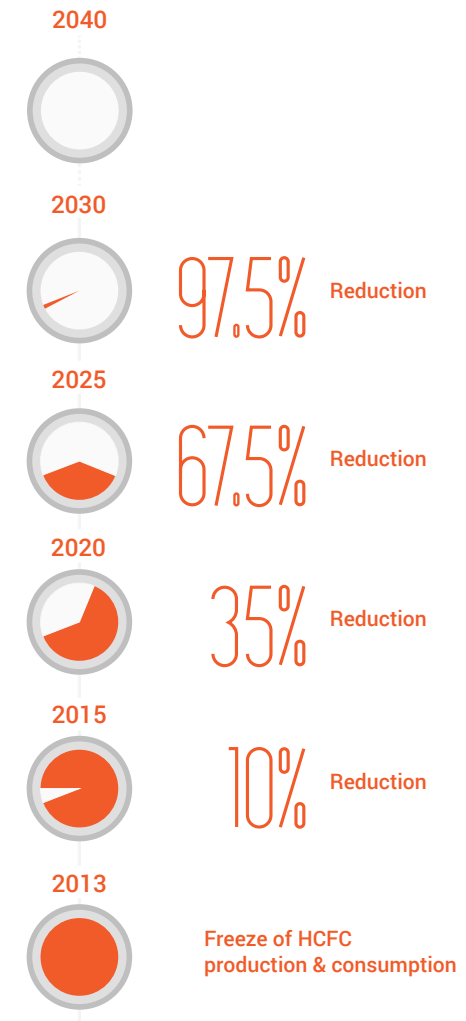

HCFCs in China to be a thing of the past by 2030

China has agreed to completely eliminate the production of HCFCs by 2030. Between 2030 and 2040 2.5% of HCFCs (compared to 2009-2010 baseline) will be allowed to service the existing equipment. As China currently manufactures 92% of HCFCs in developing countries, the phase out will have a global impact.

Pilot carbon market in Chongqing covers fluorinated gases

In June 2014, China's southwestern city of Chongqing launched the country's seventh and final pilot carbon scheme, in line with Beijing's plans to set up market mechanisms to cut carbon intensity. China has pledged that by 2020, it will reduce its carbon intensity – the amount of CO₂ produced per unit of economic growth – by 40-45% from 2005 levels. The government has also

promised to set up other mechanisms to reduce emissions, including the introduction of a national carbon scheme by 2017. Unlike the other pilots, the programme in Chongqing covers six greenhouse gas emissions apart from carbon dioxide, including methane, nitrous oxide and man-made fluorinated gases.

Increasing accountability of polluters and government for environmental issues

In 2014, China completed the revision of its Environmental Protection Law for the first time in 25 years. The updated, which officially entered into force in 2015, imposes significantly greater controls and reinforces responsibilities of corporations and local government bodies in respect to environmental protection. It strengthens the monitoring and level of punishment for those that break the law while simultaneously encouraging the public and media to help report corporations that fail to comply with the law.

In addition to imposing stricter controls and punishment, the Environmental Protection Law provides incentives to enterprises that comply with the new regime, or to those that are active in the industry related to environmental technologies. Such companies can be awarded tax breaks and fiscal assistance to further encourage improving the environmental quality. Financial incentives were identified as one of the key drivers for the HVAC&R industry to adopt natural

refrigerant-based technology according to the industry survey.

The updated Environmental Protection Law sends a clear message to the industry in China and abroad - China is getting serious about protecting the environment. The industry has positively reacted to the new environmental law and its requirements, increasing the demand for R&D staff in HVAC&R by 38.7% in May 2014, compared to the previous year. The industrial upgrading of environmentally friendly technology makes economic sense and according to the Foreign Economic Cooperation Office of the Ministry of Environmental Protection, the shift to climate friendly refrigerants gives China the chance to overtake other countries in regard to HVAC&R industrial development. As a result, the Ministry of Environmental Protection specifically encouraged the industry to pay attention to newly developing fields, such as heat pumps.



Low-GWP Label promotes natural refrigerants in RAC and heat pump water heaters

In March 2015, the Foreign Economic Cooperation Office of the Ministry (FECO) of Environmental Protection launched the Low-GWP Label together with the China Household Electrical Appliances Association (CHEAA), UNEP, UNIDO and GIZ to promote room air conditioning and residential heat pump water heaters using natural refrigerants and other low global warming potential (GWP) substances. The eligible products have to use refrigerants with no ozone depleting potential and GWP below 150.

Government puts increasingly more emphasis on energy efficiency

Due to the rapid economic development China is experiencing today, energy efficiency has become an increasingly important part of the government's policy. Over the last few years, there has been a concerted effort by the government to induce a more sustainable and environmentally friendly economy to coincide with the continuing industrialisation of China. This can be seen in the following publications and legislation, such as China's 12th National Energy Technology Plan 2011-2015, where there was a clear focus on "safety, high efficiency and low carbon emission" as the direction for future energy technology development.

In August 2013, the State Council published 'Opinions of the State Council on Accelerating Development of Energy Saving and Environmental Protection Industry' where the goal is to increase energy saving while also creating an environmentally sustainable industry. It encourages investments in sustainable industry and promotion of environmentally friendly products to consumers. It also emphasises the importance

for the industry to master key technologies to help increase China's global competitiveness in this sector. The government was also implored to improve the policy climate for environmentally friendly technology to develop.

In June 2014, the State Council released their 'Energy Resource Development Strategic Action Plan 2014-2020'. In this plan, there is again a clear focus on saving energy and reducing carbon emissions in order to develop an energy economy that is a clean enterprise. This is planned to be achieved by increasing technological progress to enhance the competitiveness of the Chinese industry.

In January 2015, the Chinese National Development and Reform Commission along with six other commissions, released the 'Practice Plan for Energy Efficiency Top Runner System' to further increase the public awareness of the virtues of energy efficiency, while offering policy support to companies with highly efficient products and encouraging more investment for an increase in energy efficiency in the Chinese industry.

Natural refrigerants could give China competitive edge in global market

In the Chinese HVAC&R market, innovation in natural refrigerant-based technology has important implications for the economy. Therefore, the government is putting increased emphasis on

maintaining a competitive edge in the world market by improving energy efficiency and keeping up with technology advancements around the globe. At the Freezer Energy Saving Technology



'Top Runner' Label encourages high energy efficiency

In December 2014, the National Development and Reform Commission published the 'Top Runner' Energy Label with six other government bodies: Ministry of Finance, Ministry of Industry and Information Technology, National Government Offices Administration, National Energy Administration, General Administration of Quality Supervision, Inspection and Quarantine and Standardisation Administration.

The label aims to increase public awareness of energy efficiency and encourage companies to invest in high energy efficient products in the Chinese market. This label is currently applicable to residential appliances, high energy consumption industries and public facilities. Eligibility for the label will be extended to additional products in the future. In Japan, the Top Runner programme has successfully helped to promote Eco Cute, residential CO₂ heat pump water heaters, due to its high energy efficiency.

and Standardization Forum, which took place in Beijing in September 2014, the Ministry of Environmental Protection's External Co-operation Centre confirmed that natural refrigerants present the Chinese industry the opportunity to surpass other countries.

In addition to these important connotations for the technical competitiveness, the increasing cost of labour is reducing China's cost-competitiveness as well; as foreign investors shift their production bases to Southeast Asia, where wages are cheaper. In order to address this issue, technological sophistication in the Chinese industry is the key to help the economy continue its growth.

One of the drivers for China's changing stance on HFCs was the changing HFC policy landscape in Europe, North America and Japan. In response to the introduction of the EU F-gas Regulation in 2015, the Chinese HVAC&R industry has warned

manufacturers to pay closer attention to natural refrigerants in order to meet export standards. When the global market - particularly Europe, Japan and North America - make the move to adopt natural refrigerants solutions, Chinese industry will have to follow the trend in production. The Chinese Government has noted that future technology developments should focus on safety, high efficiency and reduced carbon emissions, of which all natural refrigerants address.

Moreover, the government is putting increased emphasis on maintaining a competitive edge in the world market by improving energy efficiency and keeping up with technology advancements around the globe. This means that as China's export markets - particularly Europe and North America - adopt natural refrigerants, the Chinese industry will follow this trend in production.



Energy Efficiency Label for absorption chillers to boost adoption of water as a refrigerant

In March 2015, the National Development and Reform Commission published the Energy Efficiency Label for Lithium Bromide Absorption Chillers using water as a refrigerant, in collaboration with the General Administration of Quality Supervision, Inspection and Quarantine and Certification and Accreditation Administration. The label aims to enhance the awareness of energy efficiency of absorption chillers with the view of increasing the market potential for such equipment. It encourages companies to place a globally accessible QR code on the label. The label will enter into force as of December 2015 and applications can be made via a dedicated website www.energylabel.gov.cn.



Exclusive interviews - Policy

WHAT CAN THE CHINESE GOVERNMENT DO TO PROMOTE A FASTER TECHNOLOGY DEVELOPMENT OF NATURAL REFRIGERANTS IN CHINA?

Professor Ma Yitai, Tianjin University:

In Japan, the use of CO₂ as a refrigerant received government subsidy support. As a result, CO₂ heat pump water heaters have increased their market share since entering the market in 2001. In China, the government can take similar measures as the Japanese government to provide incentives for end users and manufacturers to promote the use of natural refrigerants in refrigeration and air conditioning systems.

Air source heat pumps are in fact energy saving products and have an important impact on CO₂ emissions reduction and increase of the share of non-fossil energy sources. Many manufacturers that produce air source heat pumps suggest that air is a renewable energy source, hoping to get support and subsidy from the government. In China, the 'Renewable Energy Law' regulates clearly that renewable energy could be wind-, solar-, water-, bio-, ground- and sea-sourced. But 'air source' is not included in the regulations. I suggest that when an air source heat pump uses solar energy, air source could be considered solar source in a broader definition. Air source can therefore be eligible for government support. The Chinese government is already providing subsidies towards R290 in RACs. This would help R290 increase market penetration and enhance its recognition.

Professor Yang Zhao , Tianjin University:

In the current climate, it is not sufficient to merely suggest the need to accelerate the development of natural refrigerants. In refrigerators, natural refrigerants have been used for a long time and the development phase is going well. The areas that need more government support would be reduction of safety risks.

Wang Xunchang, China Refrigeration and Air Conditioning Association (CRAA):

For systems that are already technologically developed and can be applied widely, for example NH₃/CO₂ cascade systems in cold storage and supermarkets application, the country should practice tax exemption policy for manufacturers, and provide subsidies to end users.

Professor Shi Lin, Tsinghua University:

There is need for increased investment in R&D, potential financial and technical support from the international community, as well as an accelerated process for introduction of related regulations and standards. The national policy should provide investment directions for the industry. For instance, the application of CO₂ in refrigeration application has accelerated as a result of the introduction of key technology and regulations, and this uptake is growing gradually.

IN RECENT YEARS, THE CHINESE GOVERNMENT HAS BEEN CLEAR ON THE SHIFT TOWARDS NATURAL REFRIGERANTS IN CERTAIN APPLICATIONS. WHAT HAVE BEEN THE KEY FACTORS FOR THIS DECISION?

Zhong Zhifeng, FECO:

Both the Chinese government and Chinese industry place great importance on environmental protection and international conventions. The Chinese government is encouraging the use of environmentally friendly refrigerants in accordance with the decisions taken by the Parties to the Montreal Protocol. The Chinese industry also seeks innovation toward natural refrigerants to allow for further market development.

WHICH KEY STANDARDS APPLICABLE TO NATURAL REFRIGERANT APPLICATIONS IS THE GOVERNMENT PLANNING TO RELEASE IN 2015?

Zhong Zhifeng, FECO:

For the use of R290 in RAC, there are several standards that are expected to be issued this year, these are: standards on installation and servicing process, transportation and storage process. The safety standards for industrial and commercial refrigeration and air conditioning are also expected to be drafted and should allow for the use of flammable refrigerants.



WHAT KIND OF POLICY MEASURES DO YOU BELIEVE WOULD BE THE MOST EFFECTIVE IN DRIVING THE INTRODUCTION OF NATURAL REFRIGERANTS IN CHINA?

Frank Xia, Carel:

Regarding national policy measures, the most effective one would be to ban HCFC refrigerants and move onto more environmentally friendly lower GWP alternatives. Tax incentives could also be used to accelerate the transition to natural refrigerants in China. Moreover, because a CO₂ system can achieve very high levels of COP, the use of CO₂ systems could also be a way to improve the energy consumption in line with national policy.

Stephan Luerssen, BITZER:

For the Chinese market, most end users are still at the stage of primarily considering the initial costs of a project. From this point of view, if policy can promote more natural refrigerant-based applications from a financial perspective, it would surely help to encourage the application of further NR systems. Alternatively taxes should be levied on non-NR-based systems. We can learn from the experiences of other countries, such as the Scandinavian countries, Australia and Japan.

Nobuo Yoshida, Panasonic:

Firstly, I would note that regulating related standards is of urgent concern. Secondly, I believe the provision of government subsidies when a natural refrigerant product comes on the market would be effective. Thirdly, I would encourage the promotion of natural refrigerants through industry associations to promote technical integration and communication.

An Jingai, Danfoss:

It is important to accelerate the development of safety regulations such as GB9237/GB4706. From a policy perspective, quotas, taxation and banning of HCFC and HFC in certain applications would be effective. Training for installation and servicing staff on refrigerants and system maintenance would be vital. The revised EU F-Gas Regulation is a potential game changer for the industry. It is a signal that policies will lean towards more climate friendly refrigerants in the future. I believe that this decision will also encourage a market transition to natural refrigerants such as CO₂ and ammonia in China. Danfoss, as a leader in the climate and energy industry, is prepared with the right products and solutions.

Massimo Casini, Dorin:

China's national policy will have a huge impact on the introduction of new solutions such as CO₂ in refrigeration and heat pumps. Policy will help the local industry to develop systems and applications with CO₂ for both domestic and export markets. We also believe that a planned policy for an HFC phase-out combined with financial support for end users that invest in new low-carbon emission solutions (like some municipalities are already doing for CO₂ heat pumps systems) will be the most beneficial action to speed up the introduction of CO₂ technology to the market. An official mass media campaign would also be very useful.

WHAT ARE THE STEPS THE FOREIGN ECONOMIC COOPERATION OFFICE (FECO) IS TAKING TO ENCOURAGE THE CHINESE INDUSTRY TO INVEST IN NATURAL REFRIGERANT TECHNOLOGY?

Zhong Zhifeng, FECO:

The decisions taken by Parties to the Montreal Protocol as well as those of the Multilateral Fund support the development of natural refrigerant technology and encourage the industry to move in that direction. Other ways FECO together with the China Household Electronics Application Association provide support to stakeholders is through risk assessment, technology and standards development and the conversion of production lines to natural refrigerants, amongst other initiatives organised with the support of other stakeholders.

Abel Gnanakumar, Emerson Climate Technologies

- 1) Strict limitation for HCFCs and high-GWP refrigerants.
- 2) Improving CO₂ and hydrocarbon refrigerant product standards certification
- 3) Training for CO₂ and hydrocarbon refrigeration application
- 4) Consider national subsidies for projects that use environmentally friendly refrigeration systems.

An ecosystem approach

The purpose of the 'ecosystems' is to highlight the recent developments in a variety of natural refrigerant-based products and technologies currently in use in China. The examples mentioned aim to provide insights into the experiences of a range of Chinese manufacturers, suppliers and contractors, as well as end users that drive the adoption of natural refrigerant-based technology. The cases highlighted also allow for a deeper analysis of the different business models currently used in various HVAC&R sectors in China.

CITY & BUILDINGS: Natural refrigerants can be used in a variety of applications in public and commercial buildings, data centres, district heating and cooling and private residential housing. This section provides an overview of the latest application examples across China.

INDUSTRY, SPECIAL APPLICATIONS & SPORTS: Natural refrigerants are also applied in larger scale applications such as industry processing in laboratories, pharmaceutical, petrochemical industry, agriculture and power plants. Sports facilities such as ice rinks and ski halls in China use natural refrigerants such as ammonia and CO₂. Natural refrigerants are selected for their effectiveness and stable cooling and heating properties.

FOOD CHAIN: Natural refrigerants are widely adopted in food and beverage storage, distribution, production and processing, and supermarkets. This section highlights different examples available, which use natural refrigerants.



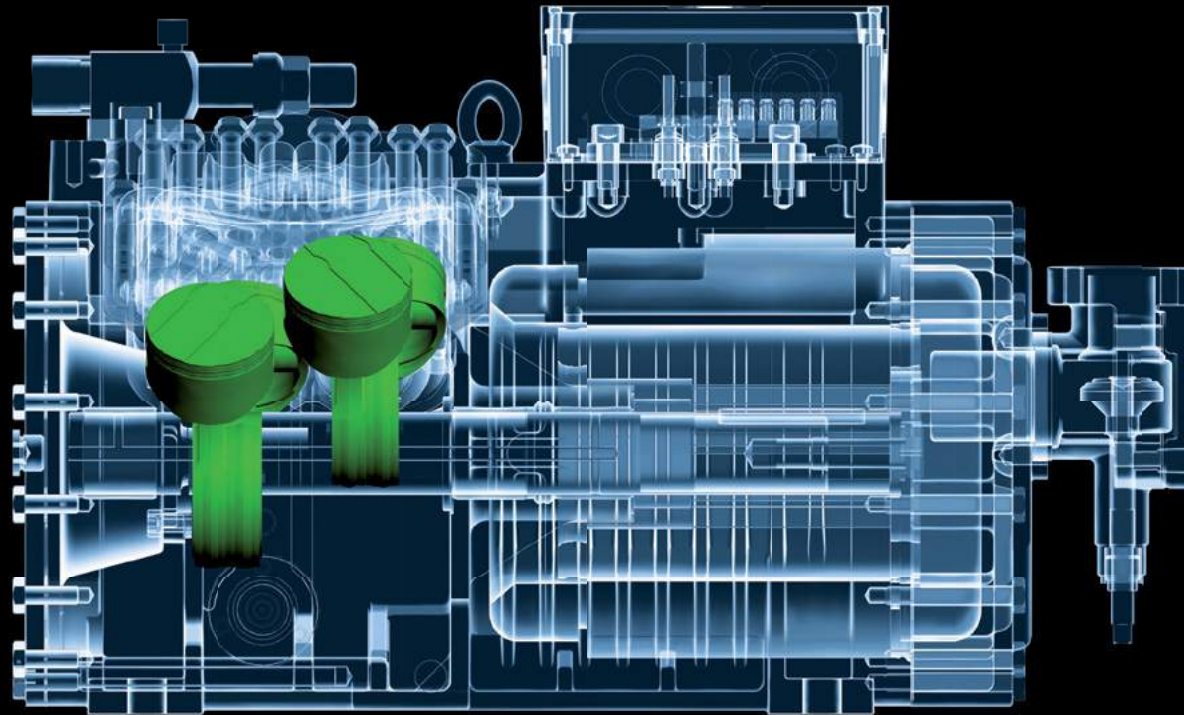

OCTAGON CO₂

CO₂ AS A REFRIGERANT?
ABSOLUTELY!

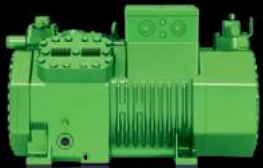

The compressor is the heart of every refrigeration system. This heart now beats for the environment – with CO₂. At these high pressure levels you need a product you can rely on. As the market leader in CO₂ reciprocating compressors, BITZER offers quality and peace of mind – plus a broad product portfolio and services to match. When you turn to BITZER, a strong heart ensures a better life. Learn more about our products at www.bitzer.de



THE HEART OF FRESHNESS

City & buildings

PUBLIC & COMMERCIAL BUILDINGS: OFFICE & GOVERNMENT BUILDINGS, UNIVERSITIES, HOSPITALS, HOTELS, TRAIN STATIONS

CO₂

In 2011, Shenyang's Children's Hospital installed a combined heating system with two CO₂ heat pumps and 200m² of solar thermal collectors to cater for the hospital's relatively high space heating and sanitary hot water needs. The CO₂ heat pumps are capable of supplying 40 tons of hot water at 60°C per day to the hospital, including when temperatures hit lows of -28°C during the winter.

In October 2011, Wuhan University installed a CO₂ heat pump water heater, providing hot and clean drinking water for the students. The combination of a CO₂ heat pump and an electric boiler saves the university 50% in energy usage compared to just an electric boiler. By firstly heating water to 80°C with the CO₂ heat pump, and then to 100°C with the electric boiler, the system is able to efficiently provide students up to five tons of hot drinking water per day.

A hotel in Shanghai introduced a CO₂ heat pump installation. Compared to their conventional fuel boiler, the CO₂ heat pump system reduced the running cost by 80% and returned the investment in eight months.

A 3,000m² office building for the Beijing TongZhou District Bureau of Quality and Technical Su-

pervision in Beijing installed four CO₂ heat pump units in 2011 to provide heating and cooling. In the 800m² dining facility of the bureau, another CO₂ high temperature heat pump is used to provide space heating during the wintertime.

Bumade railway station uses three 50kW CO₂ heat pumps to provide space and water heating for its 3000m² maintenance area. The project is especially notable because the railway station stands 4800m above sea level. However, it is not just the height which is extreme; the heat pumps work well even during Bumade's winter period when the outside temperature can be as low as -30°C - the coldest operating temperature for this type of a project in China. Because of the high energy savings and stable performance of the project, 24 CO₂ heat pump units were installed to provide space heating in another five railway stations on the Qinghai-Tibet railway line.

CO₂ heat pumps are also installed in Dandong city's railway station to replace an electric boiler. The CO₂ heat pump provides daily hot water and space heating during the winter period. The COP reaches 3.2 with outside temperatures of 12-17°C and even at a temperature of -25°C, the COP was measured at 1.36, with the system achieving energy savings of 49.67%.

H₂O

By the end of 2013, over 310 million m² solar collectors had been put into use in mainland China, which accounted for approximately 70% of the global solar collector area. Given that China is already the biggest market for air conditioning, with rapidly increasing demand, solar air conditioning is expected to play an important role and is already registering a lot of interest. Lithium bromide-water absorption chillers are estimated to have a market share of more than 8%. Absorption chillers have been widely used in China for central air conditioning in commercial, office buildings and universities.

A solar cooling system is applied at a university campus library in Hainan Island, which is the southernmost province in China. The solar cooling system was designed to offer 25% of the

total cooling energy consumption of the building. The mechanical room is located on the first floor of the library. A single effect lithium bromide absorption chiller with capacity of 316 kW and an electric screw chiller with a capacity of 1044 kW were selected as the cooling source.

A solar powered adsorption air conditioning system was installed in the Shanghai Jiao Tong University, in a 460m² building. The system included 150m² solar panels and two adsorption chillers with a refrigeration capacity of 8.5 kW. The operational performance of the system showed that the average refrigeration output of the system was 15.3 kW, during an 8-hour operation, and the maximum value exceeded 20 kW, which meets the air conditioning demands of the whole building.

Hydrocarbons

In 2010, a project utilising R290 wall and cassette split systems as well as air-cooled water chillers, was completed at a high-tech R&D centre for a global PLC Company. The split sys-

tems use only 440-600g of refrigerant, while the chillers use 1.2kg per circuit.

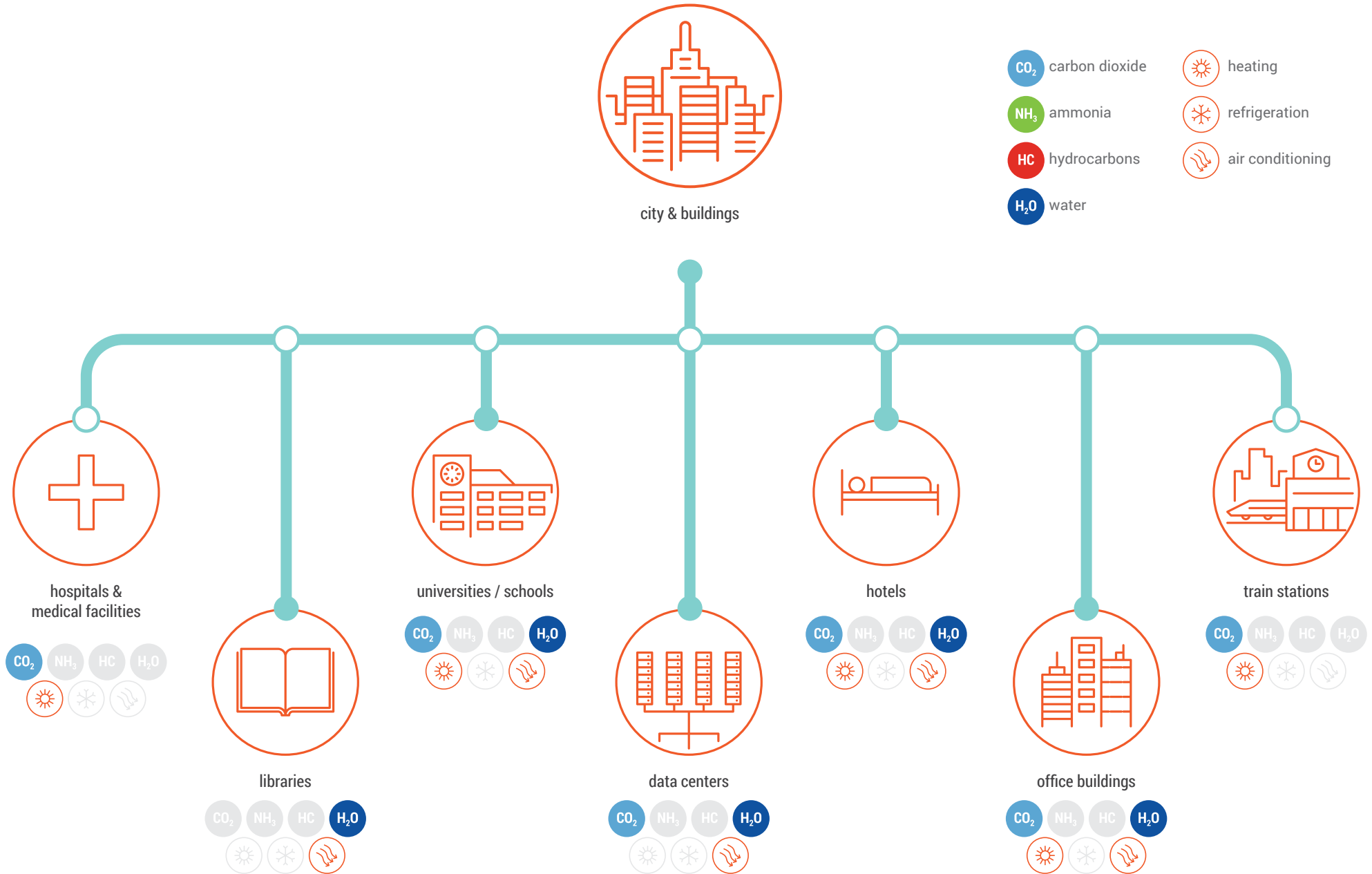

DATA CENTRES

CO₂

Beijing Topnew Info & Tech Co. has installed cooling systems which use CO₂ in two of their Beijing large-scale data centres with a combined area of 2,000m². The CO₂ system improves the data centres' overall operational efficiency by roughly 11% and consumes 25% less energy. The customised design of the data centre also helps by reducing the height of the room, sub-

sequently reducing the installation cost of machine rooms and reducing the initial investment of the project. The CO₂ solution's environmental benefits include helping to reduce energy consumption significantly and avoiding risks associated with water leakage in the conventional system.

DISTRICT HEATING & COOLING

CO₂

Thirty CO₂ heat pumps have been installed in a military base in Kunming city in Yunnan, Shangri-La region. Due to a scarcity of coal in Shangri-La, heating has been a big issue for the military, so the CO₂ heat pumps have effectively solved the heating issue for the 25,000m² base.

In a 1,000m² military base in Qingdao, a CO₂ heat pump system was installed in 2010, which now provides heating for the entire area. The system has achieved high energy savings and also improved the ease of management and control of the system.

H₂O

In another project in Dogsheng utilises absorption heat pumps to exhaust steam (8kPa) to generate residential district heating (50–82.5°C). The same technology is used by a local manufacturer in Nanjing, Jinling to generate steam from available waste heat, thus saving 12

million RMB a year (EUR13.8 million).

RESIDENTIAL / PRIVATE HOUSING: RESIDENTIAL AIR CONDITIONING, HOT WATER HEAT PUMPS, REFRIGERATORS

Hydrocarbons

In China, the development of R290 technology for residential room air conditioners is already underway and has been supported by the Multilateral Fund of the Montreal Protocol as part of the HCFC Phase Out Management Plan. Overall, three compressor production lines and 18 RACs production lines are being converted to R290-based technology. As China accounts for 70% of global RAC production, the conversion to R290 will have a huge impact globally. While the production for some export markets has already started, the commercialisation of RACs

using hydrocarbons as a refrigerant for the domestic Chinese market is likely to be initiated in 2015.

With the increasing emphasis on environmental protection in China, the sales of R600a refrigerators is continually growing and more manufacturers are beginning production. Currently, almost all new domestic refrigerators in China use hydrocarbons as a refrigerant.

CO₂

In 2014, the first residential CO₂ heat pump water heater (HPWH) was launched by a local manufacturer. The HPWH technology was then recognised as a leading technology by China's National Light Industry Council. In 2015, other leading manufacturers plan to launch their CO₂ heat pump water heaters. The HPWH produces hot water with temperatures as high as 90°C, whilst conventional heat pumps can only reach 55°C. Another advantage is the heat pump's ability to work efficiently in different climates, being able to work temperature ranges from -25°C to 43°C, meaning it can be widely applied in northern and southern China.

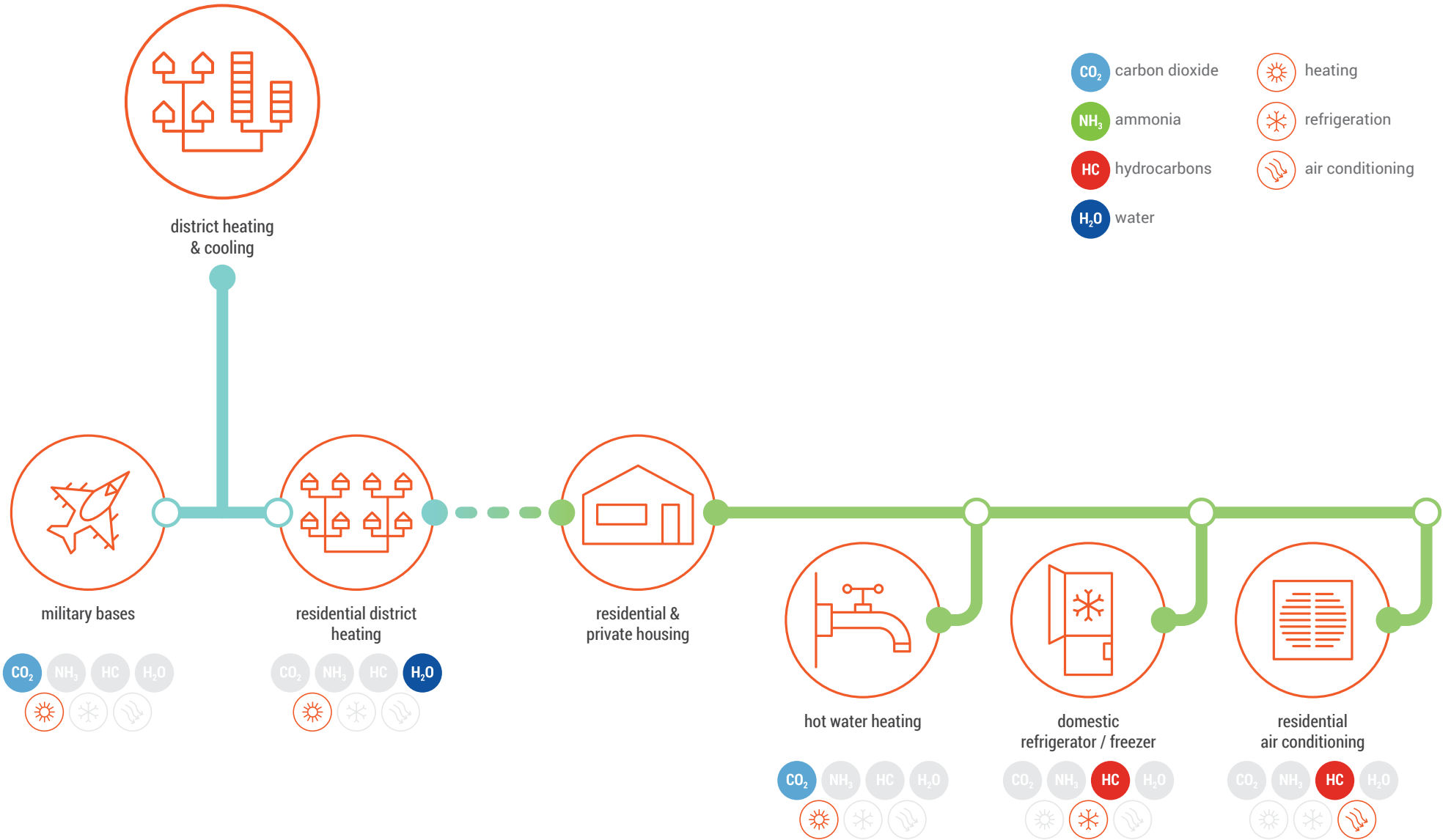

Industry, special applications & sports

INDUSTRIAL PROCESSING

NH₃

Novo Nordisk, a pharmaceutical company, introduced an ammonia-based refrigeration solution into its Tianjin factory, a global production plant based in China. Eight units of ammonia refrigeration compressors were installed for cooling insulin in a flame-proof area. According to the feedback from Novo Nordisk, the ammonia refrigeration system has an effective and stable cooling performance.

A refrigeration station of a methylethylketone (MEK)-benzene dewaxing unit at Beijing Yan Shan Petrochemical Corporation Refinery Business Division was built in 1969. Using ammonia as a refrigerant, its main duty is to provide cold source for the MEK/benzene crystallisation

section. Five ammonia refrigeration compressors were installed at the refrigeration station: two for -20 °C evaporation system with refrigeration capacity of 10.5 MJ/hr/unit ammonia refrigeration compressor; and three for the 42 °C evaporation system with refrigeration capacity of 5.6 MJ/hr/unit ammonia refrigeration compressor.

NH₃/CO₂

A NH₃/CO₂ cascade cooling system has been installed in the plant of Jiangsu Zhongneng Polysilicon Technology Development Co, Ltd., the world's third largest polysilicon manufacturer, located in Jiangsu province. The system has proved successful when working at low temperatures.

LABORATORIES

Hydrocarbons

A hydrocarbon refrigeration system was installed in an edible-mushroom research institute in China's Fujian Province in 2012. The system was manufactured by a local refrigeration engineering firm and from experiments conducted involving two growing cycles of mushroom, the hydrocarbon refrigeration system has proven to use 19.8% less energy compared to the old

HFC-based refrigeration system equipment in the institute.

AGRICULTURE

NH₃

In August 2013, YUNNAN Asean Agricultural Product's 6,000-ton ammonia distribution centre was completed in the Yunna province. The distribution centre, the largest in the area, uses ammonia in its refrigeration system. To ensure the quality of agricultural products and consumer security, safety is one of the most important concerns in the design and build of this cold store. In order to ensure safety, the manufacturer has implemented monitoring and detection devices to measure and alert about potential ammonia leakage.

H₂O

Solar-powered adsorption chillers have been installed in four grain storage facilities in China's Jiangsu Province. Usually the middle and bottom grain layer temperatures in a storage facility are maintained below 15–20°C. The temperature in the upper layer usually increases quickly, and sometimes the temperature exceeds 30°C. These adsorption chillers are used to maintain low temperatures in grain storage during hot seasons by cooling only the headspace inside the bin. The corresponding electrical COP of these systems is between 2.6 and 3.4, which is far higher than that of the usual mechanical vapour compression chillers. Solar adsorption air conditioning systems could therefore be considered an alternative for low-temperature grain storage in other provinces of China.

POWER PLANTS

NH₃

Off the coast of Hainan in southern China, an Ocean Thermal Energy Conversion (OTEC) power plant is being constructed, with an expected completion date of 2017. OTEC represents a sustainable and continuous energy source that is capable of producing high levels of electricity.

To do so, it utilises the temperature difference between the warmer water found at the surface and the cooler water found at the depth, that forms the basis of this technology. The power plant will be configured as a closed-cycle system and will be the world's largest OTEC facility. Without using fossil fuels, and using ammonia as a refrigerant, the system meets electricity demand by harnessing solar energy that the seawater has absorbed. The completed power plant will generate electricity that will be supply a resort built by the Reignwood Group on the Hainan Island.

SPORTS FACILITIES

NH₃

Ammonia refrigeration was selected by the Government of Daqing to develop the Daqing Speed Olympic Park project. The project was completed in 2014 in what was one of the largest ever refrigeration projects launched in the sport sector in Asia. A tailor-made ammonia refrigeration system, with a cooling capacity of 2860 kW, was designed for the facility. The speed oval covers 23,385.5 m² and holds a Grade A certification in architecture. The system is comprised of four sets of screw compressors connected to two PHE ethylene glycol coolers. For cooling purposes, the ethylene glycol is circulated between the condenser and provides high efficient refrigerant condensation, close-loop cooling, combined with thermosyphon cooling system. The ice rink and speed oval includes a control system that enables the user to adjust the temperature of the ice surface between -2°C and -8°C, depending on the activity on ice. The refrigeration plant and its energy consumption, the lighting, heating, air conditioning, ventilation and dehumidification systems, as well as the ice thickness and harness, could be also monitored and controlled.

H₂O

Datang Harbin thermal power plant is equipped with two sets of 300 MW generating units as well as six 38.77 MW absorption heat pumps, which extract heat from circulating water; increasing the total heating capacity of the power plant.

Datang corporation, a Chinese power-generation company, introduced absorption chillers to Sanmengxia thermal power plant in Sanmengxia city, Hainan province. The planned power capacity of the plant is 3840 MW and the first absorption chiller will start its operation in September 2016.

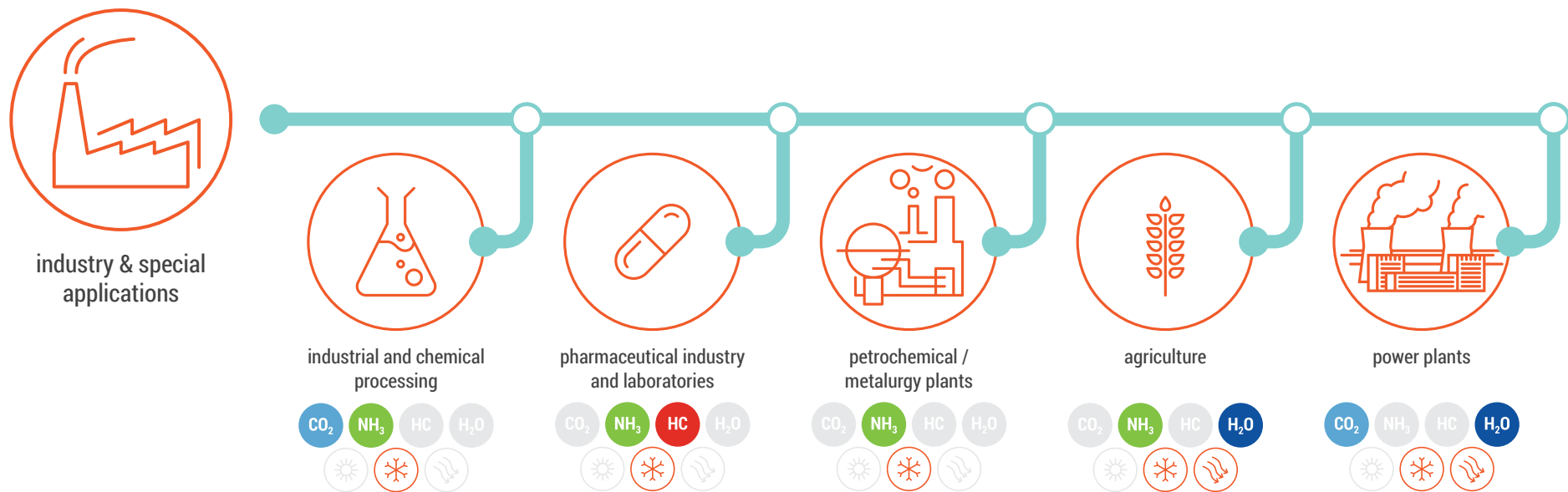
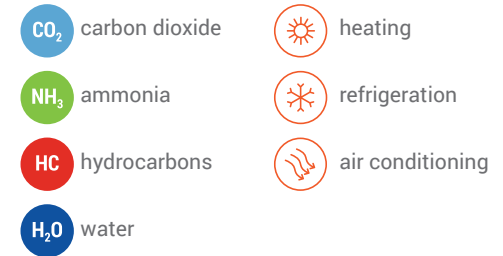
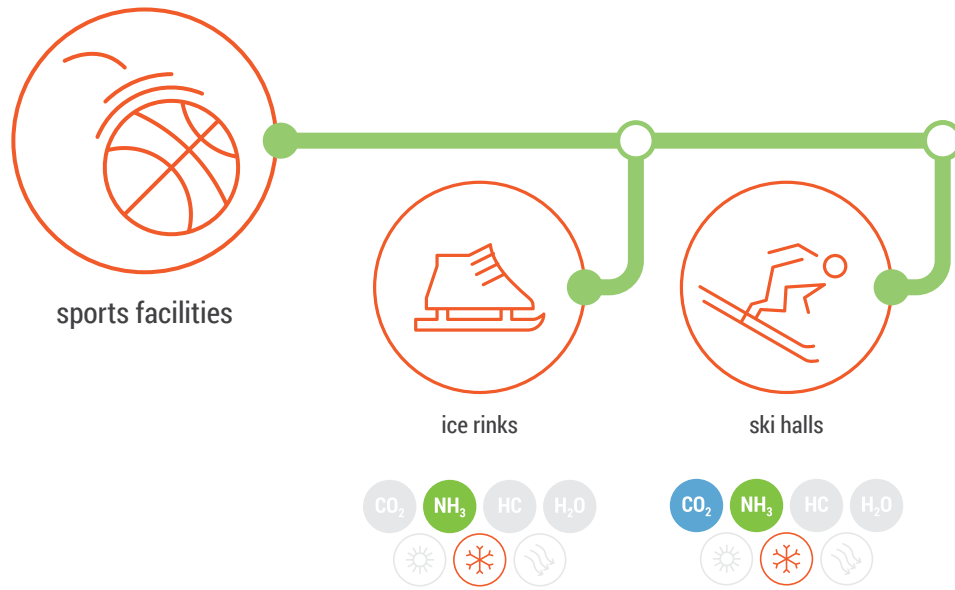

THE POWER OF BRAINS

A machine is only as good as the engineer who built it



CD300 SERIES CD 1900H MODEL

Compressor CD1900H from the CD300 series, is ideal for the optimisation of space thanks to its extremely contained size and weight.

Specifically suggested for refrigerated transport and heat pump applications, it is the largest 2-piston model of the CD range characterised by a displacement of 11.62 m³/h and Pss of 100bar.



OFFICINE MARIO DORIN SINCE 1918

DORIN[®]
INNOVATION

www.dorin.com | dorin@dorin.com

Food chain

BREWERIES & WINERIES

NH₃

In 2013, Snow Beer, a large Chinese brewery, completed its new plant in Kaili, Gui Zhou province. Automatic control solutions have helped its ammonia refrigeration system in the entire process of brewing: wort processing, yeast propagation, fermentation, beer cooling, and more. The compact design led to significant space savings for the system and increased efficiency with high security of maintenance. In addition to this, the automatic control solution has helped the Kaili plant reduce the possibility of human error. The set of solutions applied in the refrigeration system of the Kaili plant has become a successful template for Snow

Beer in its new plants around China.

The first production base of Budweiser in Southwest China, the Ziyang factory in China Sichuan province, adopted an ammonia refrigeration system. A series of innovative ammonia industrial refrigeration components greatly reduced the costs of the project - 50% cost savings in valve installation and more than 30% cost savings in valve maintenance and operation costs, were achieved.

FOOD PROCESSING

NH₃

In 2013, the Grand Farm, a leading slaughtering and meat processing company in China, invested in building one large-scale livestock product processing plant, which applied an ammonia refrigeration system with the accurate temperature control to meet the strict quality product standards to ensure the freshness and nutrition preservation of the meat. A customised hot gas defrosting system with more than 50 ammonia valve station components was installed, guaranteeing high efficiency and cost savings, as well as reducing low pressure drop and downtime for the refrigeration system. Moreover, the project is located in Hei Longjiang province, where the average temperature drops to -20°C in winter. Despite this challenge, the system was successfully installed and works very well.

NH₃/CO₂

Yantai Feng Run Logistic Company installed a NH₃/CO₂ cascade refrigeration system for the processing and storage of canned fruit. The NH₃/CO₂ cascade system has reduced the company's annual electricity consumption by 10%. The comprehensive refrigeration solution provides the company with a safe and fully automated control system.

INDUSTRIAL COLD STORAGE, WAREHOUSES

NH₃

Ammonia systems have been traditionally used for large capacity plants in the industrial refrigeration sector. In recent years, increased focus has been put on measures to ensure better safety in ammonia refrigeration plants, such as automatic controls. Tianyuan Foods installed an automatically controlled ammonia refrigeration system in a large-scale cold storage in Liangyungang City, Jiangsu province. The project was the first ammonia installation with an automatic control system that aims to ensure the system's reliability, energy efficiency and safety. The overall cooling capacity of the facility is 19,500 tonnes. In the first year of operation, over 25% electricity consumption reduction was achieved compared to a conventional cold storage.

NH₃/CO₂

NH₃/CO₂ system have been widely applied in different application sectors in China. So far, there are more than 34 projects in industrial refrigeration using CO₂ as the refrigerant, with NH₃ mostly used in cascade or secondary refrigeration system. Current application fields are in ice making, slaughter processing, logistics and cold storages, aquatic products processing, artificial ski halls, fruit and vegetable processing, processed good and in the ice cream industry.

Rushan Huaxin Food Company, a Chinese producer of seafood, fruits and vegetables for export, installed a NH₃/CO₂ refrigeration system in its cold storage in Weihai, in Shandong Province. In 2013, the Chinese Ministry of Environmental Protection (MEP) named the cold storage 'Demonstration Project for NH₃/CO₂ Environmental Friendly Alternative Refrigerant Technology for the Chinese Commercial Refrigeration Industry'.

In June 2014, Jiangsu Tianyuan Group started operating their cold storage using two sets of NH₃/CO₂ refrigeration systems. The cold storage features some of the newest technology, such as dual-temperature design and air passage, using nylon fabric.

In June 2014, the first CO₂/ammonia secondary cold storage in northwest China, with a refrigeration capacity of 100,000 tonnes, was signed to be installed in Lanzhou.

CO₂

A large logistic company in China is in the process of building a 150,000-tonne CO₂ transcritical distribution centre in Beijing. The owner of the distribution centre insists on using only CO₂ as a refrigerant in the project to ensure the quality of food stored in the distribution centre. According to the company, the 30,000m² distribution centre will consist of eight independent cold storages with temperatures as low as -25°C. The facility will also have a -60°C ultralow temperature cold storage. Once established, the distribution centre will be the largest CO₂ transcritical project of its kind in China, in terms of capacity.

Nestlé chose to install CO₂ systems in its low temperature cold storage in Harbin. In the

FISH PROCESSING

NH₃/CO₂

In June 2013, the largest cold storage facility for aquatic products in northeast China was established in Dalian. The Zhangzi Island project is the first large-scale cold storage logistics base to adopt a NH₃/CO₂ cascade refrigeration system in China. The project is seen as a milestone for CO₂ refrigeration in the country, as it is the first combining both CO₂ cascade and CO₂ brine systems. The freezing plant lowers the NH₃ charge amount by over 90% and limits the NH₃ refrigerant inside the refrigeration control room, fully satisfying the safety requirements of Zhangzi Island group. The cold storage plant utilises a CO₂ brine system and abundance of surrounding sea water as the cooling medium for the high level ammonia refrigeration.

Ocean Star Aquatic Products CO., LTD, a Chinese seafood processing company, built a

108m² frozen storage room, there are three CO₂ refrigeration systems with a total cooling capacity of 40kW. The CO₂ refrigeration systems use 2°C chilled water produced from food processing.

CO₂/ HFC

In August 2013, the Care Cold Chain International inaugurated its logistic park project in Chongqing China. The project has attracted much attention as it was the first R404A/CO₂ cascade refrigeration system installed in China. The cold storage covers an area of 45,995m² and can reduce operation costs by about 30%. This CO₂ cascade refrigeration system also features dynamic ice-bank technology, using the systems to meet the refrigeration needs of the 100,000 tonnes storage capacity. The new cold chain logistics park became the benchmark project and leads the trend in China.

300,000-ton ammonia cold storage in 2012. The seafood processing facility is located on a 49.4 acre in Zhangzhou, Fujian Province, China. The facility contains a 1,000m² refrigeration engine room with an ammonia refrigeration system. The cold storage has 12 production lines with an annual seafood processing capacity of 800,000 million tons.

SUPERMARKETS

CO₂

China has been making strides in the use of CO₂ in supermarket applications. As the number of stores using CO₂/HFC cascade system continues to increase, the industry is also exploring the use of CO₂ transcritical solutions for supermarkets in China. Currently, there is one supermarket in Dalian trialling a CO₂ transcritical system. Once the testing phase is complete, it is expected that more CO₂ transcritical stores will be developed in China.

CO₂/NH₃

Since 2013, the use of CO₂/ammonia has been growing rapidly in industrial refrigeration in China, and the solution is recognised as suitable for commercial applications. There is currently one store in Shandong province using a CO₂/ammonia system. This trend is increasing the amount of options available for end users to adopt natural refrigerants.

CO₂/HFC

In August 2011, Tesco opened the first store using CO₂ as a refrigerant in China (Shanghai). In the CO₂/HFC store, a series of energy saving technologies are used. The store has adopted an advanced Environmental Management System (EMS) and many energy reduction measures such as LED lights, and a heat reclaim system. The store captures waste heat to produce hot water and reduce fossil fuel use. With the CO₂ cascade system and other measures, the store can save up to in of its energy use, with an annual reduction of 9.7 million kilowatt hours in power and savings of 1560 tonnes in carbon emissions.

On January 2013, Tesco opened its third CO₂ supermarket in China in the southern city of Xiamen. The CO₂ system is expected to save the supermarket up to 25% in annual electricity costs. With a series of energy saving technologies and equipment like CO₂ refrigeration and LED lighting, the store can save up to in energy consumption. This reduction equates to an annual reduction of 1.22 million kilowatt hours in power and savings of 1770 tonnes in carbon emissions.

In December 2014, Metro opened its first CO₂ /HFC store in China, in Weifang, as part of their environmentally sustainable growth in China. From the data so far, Metro is very satisfied with energy saving results of 30%-40% compared to a conventional system.

LIGHT-COMMERCIAL SYSTEMS: BOTTLE COOLERS, CABINETS, ICE CREAM FREEZERS AND VENDING MACHINES

CO₂

Coca-Cola has incorporated CO₂ refrigeration technology in its business strategy in China since 2008. From 2008-2009, Coca-Cola introduced 13,300 units of CO₂ coolers to China. In 2010, another 5,000 units were placed on the market and in 2011, another 13,566 CO₂ cold-drink equipment units were purchased. From the beginning of 2015, The Coca-Cola Company has placed more than 25,000 units of CO₂ based equipment in the China. Coca-Cola aims to reduce the carbon footprint of “the drink in your hand” by 25% through end-to-end value chain by 2020. As a method to achieve the goal, Coca-Cola aims to phase out the use of HFCs in cold drink equipment. The goal is to use 100% HFC-free equipment by 2015.

HYDROCARBONS

As the leading ice cream manufacturer in China, Unilever is committed to using hydrocarbons in their units. In 2012, the overall number of hydrocarbon ice cream freezers in China reached 18,000 units. In 2013, the overall number had nearly doubled, reaching 34,000 units. Unilever’s goal is to continue to accelerate the use of hydrocarbons ice cream freezers.

Chinese dairy product maker Mengniu reached a partnership agreement with local manufacturers to produce and launch 20,000 cabinets using R290 as refrigerant. The R290 model was developed with local manufactures and has energy-saving and low-noise benefits including reducing electricity costs by more than 30%.

Red Bull switched to ECO-coolers using hydrocarbons as a refrigerant at the end of 2013. ECO-coolers combine the use of hydrocarbons and cooler technical improvements by using energy efficient fans. The model can save up to 45% more energy compared to previous cooling equipment. In China, Red Bull only uses hydrocarbons as a refrigerant in its new coolers has 2,275 stand-alone ECO-coolers in China.

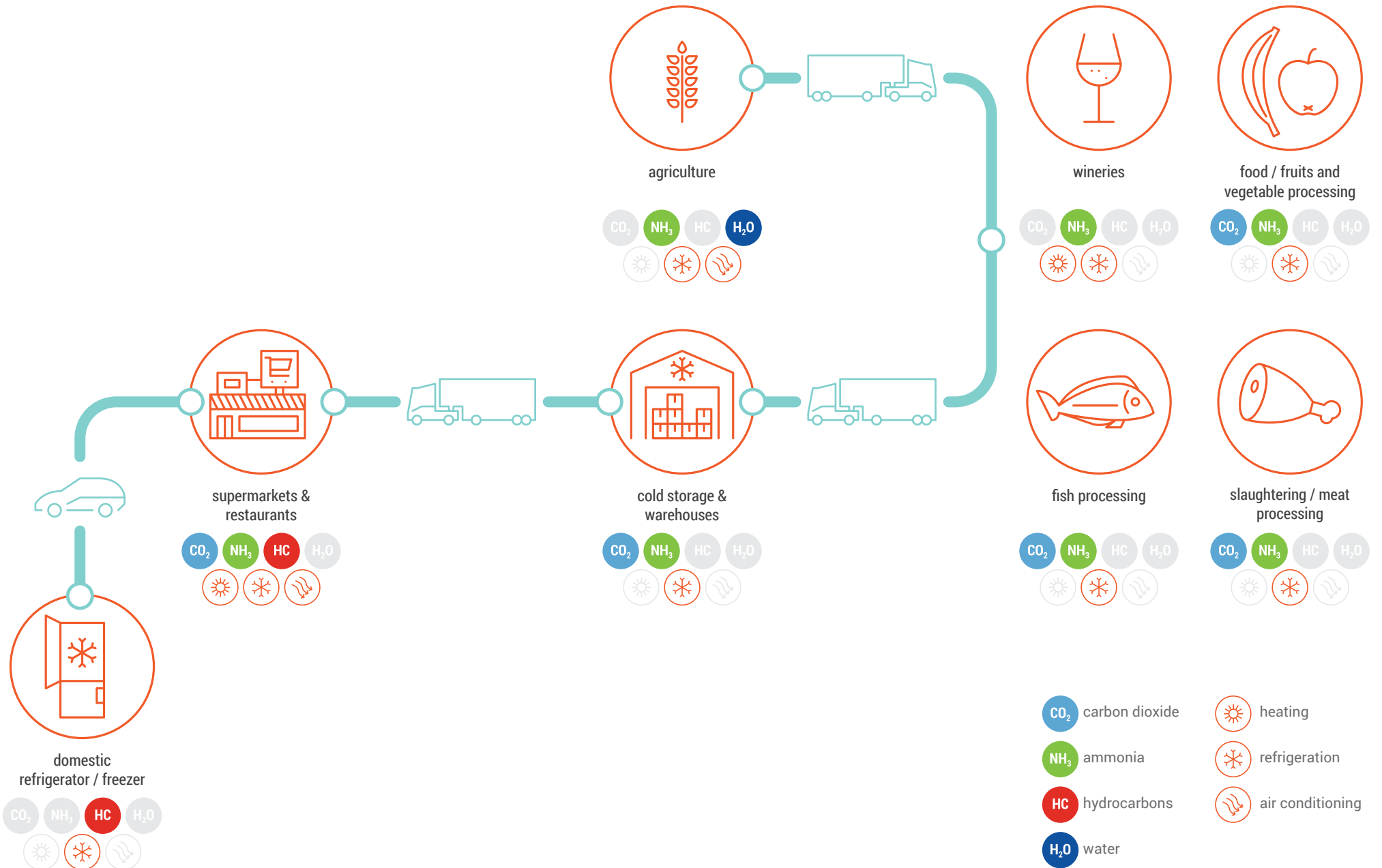

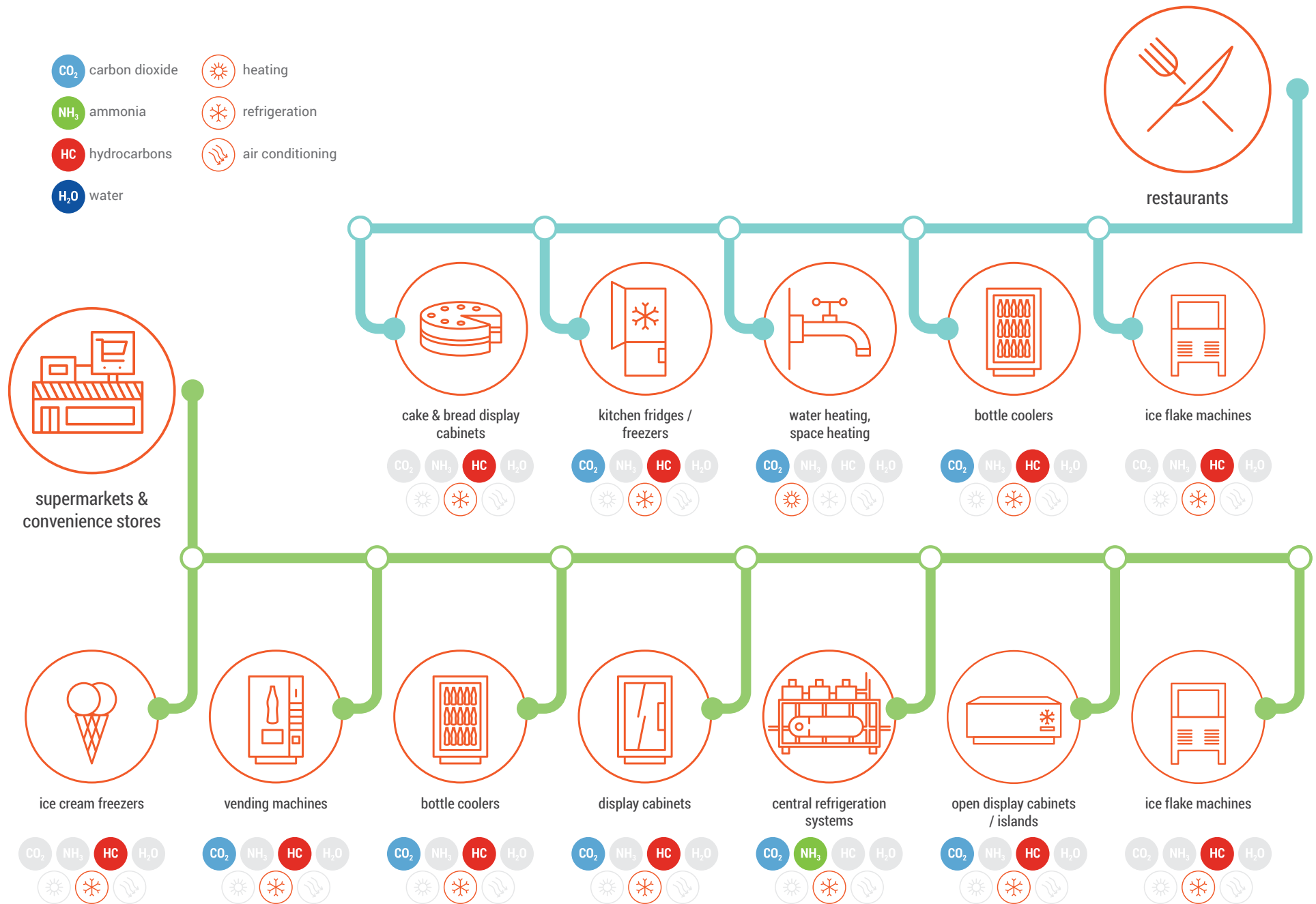

UNLOCK THE MARKET FOR CLIMATE FRIENDLY TECHNOLOGIES



- Market outlook based on industry surveys
 - Technology & market maps
 - Interviews & case studies
- Free to download on publications.shecco.com

For more information please contact:
Nina Masson, Deputy Managing Director, research@shecco.com, +32 2 2303700



Market potential for natural refrigerants in China TOMORROW

Introduction

The survey results reveal that the natural refrigerant market in China will grow in both supply and demand. Within this anticipated growth, CO₂ is perceived as the refrigerant that will have the highest growth potential in all application areas; from industrial, to commercial and light commercial, in refrigeration as well as heating. Hydrocarbons also have a very promising future in commercial and light-commercial applications in addition to recent developments in RAC applications. The last of the 'big three' natural refrigerants, ammonia, has the highest potential for adoption and growth in the industrial refrigeration sector, but already has a secure market share.

To complement our findings from the survey, the interviews that follow reveal potential policies for phasing down HFCs, as well as detailing the progress of technological development in the industry and what the market potential will be in the future from academics, industry and end users. Lastly, the recommended action plans from the interviewees depict how China can best accelerate natural refrigerant-based solutions in the Chinese market in the coming years.

Future trends for natural refrigerants

Growing number of new entrants contributes to market transformation in the future

When current non-natural refrigerant users were asked about their future implementation of natural refrigerants, 50% stated that they plan to provide natural refrigerant products and/or services. Around 32% of respondents said they were yet to make up their minds, indicating that almost a third of the market potential for growth lies with these companies. 18% have decided that they will not introduce products and services with natural refrigerants in the future.

When these future adopters were asked about which refrigerant they will adopt and when, it is clear that there is a preference for the year 2020 for the adoption of hydrocarbons (26%) and CO₂ (34%). Nevertheless, a large portion of those who wish to provide natural refrigerant products and services have not yet decided on the exact timeline - Of this portion, 42% want to invest in CO₂ products in the future, 49% want to work with hydrocarbons, while a significant number intend to use technology utilising ammonia (79%). The uncertainty could come from companies waiting for government action or increased demand in China, and abroad, before investing. Still the message is clear - a large amount of companies will be entering the natural refrigerants market in the near future.

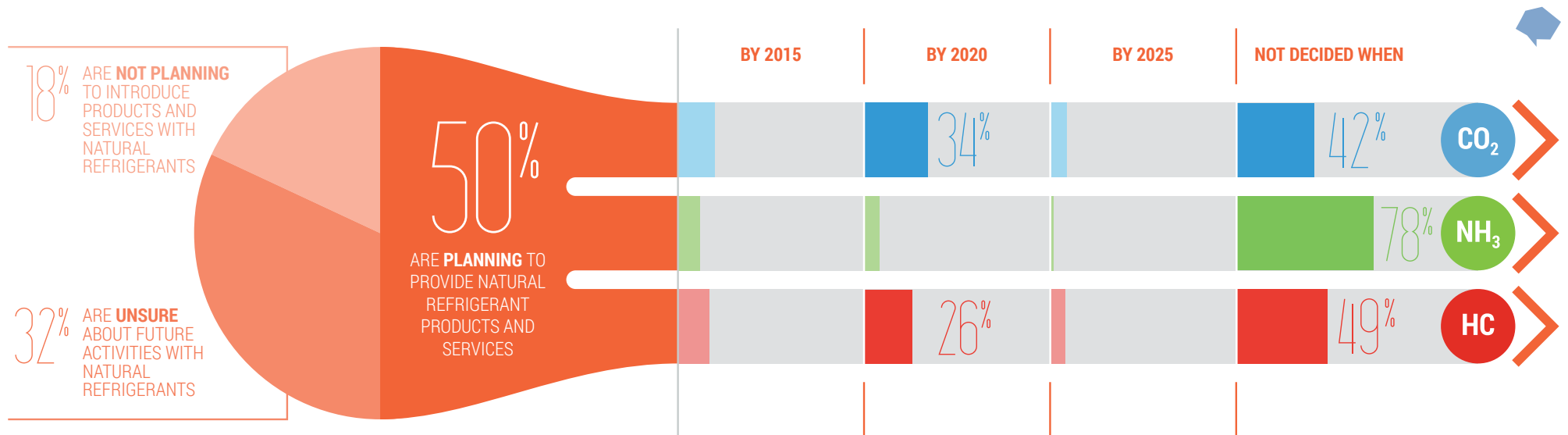

Number of respondents: 373

FLEXIBILITY OF CO₂ ENSURES A GROWING MARKET SHARE UP UNTIL 2030

The increase in suppliers entering the CO₂ refrigerant market will have a clear impact on the total market share of CO₂. By 2020, over a third of respondents expect the share of CO₂ to make up between 10%-20%. This immediate rise can be seen as a response to many recent developments, including the increasing use of CO₂ in commercial refrigeration as foreign supermarkets prove that potential efficiency gains are possible without harming the environment. But more substantially, the use of CO₂ in industrial refrigeration is expected to become the biggest advancement in the use of any natural refrigerant, in any application, according to the industry survey. There is also a clear trend for the use of CO₂ in light commercial refrigeration, with industry expecting demand to outstrip that of hydrocarbons for this application by 2020.

Forecasts for the use of CO₂ in 2030 show a subtle shift towards a more solid market share, with a third of respondents still believing that CO₂ will have a market share of 10%-20%, but perhaps more importantly, another third expect CO₂ to possess a 21%-50% market share in 2030,

compared to just 8% of respondents in 2020. Outside of the aforementioned applications, CO₂ is also beginning to make waves in the heat pump market as Japanese firms continue to eye up the Chinese market, and local manufacturers start to commercialise their products.

Other explanations for the solidification of market share by 2030 come from the drop in price that is expected as a result increased market saturation for CO₂-based technology. Other expected progress, such as an increase in training, turn the progress CO₂ has made into a concrete market share.

For the future, these predictions are exciting and show a gradual evolution that will see CO₂ become a mainstream refrigerant within China, which aligns with other major economies such as the U.S. and Europe. With the wide range of applications that CO₂ can be used efficiently in, there could soon be a prevalence of the natural refrigerant that would not have been anticipated 10 years ago.

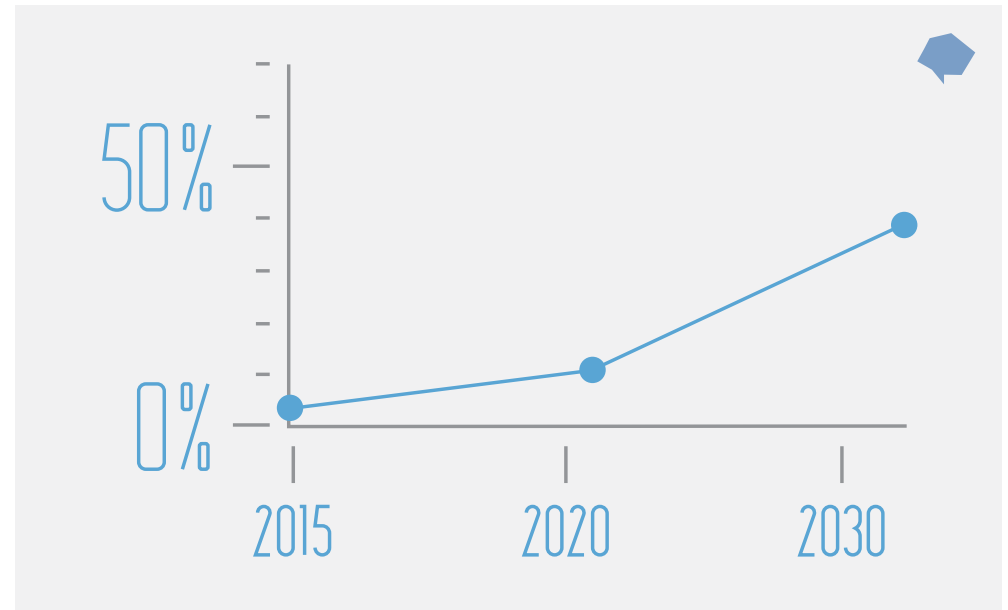

Number of respondents: 1,054

NH₃ SHOWS MARKET MATURITY IN THE COMING DECADE

For ammonia, the market share remains mostly unchanged between 2020 and 2030. As China has a long history of using ammonia that stretches back 60 years, we can infer that this stagnation is due to the established place ammonia already has in the market. This contentment can be seen by the industry survey that ranked ammonia in industrial refrigeration as the best current application using natural refrigerants, in terms of business and policy climate.

forecasts. Expectations for the market share of ammonia in both 2020 and 2030 show that 70% of the industry believe the market share will be beneath 20%. Nevertheless, a relatively high percentage of respondents believe that the market share will be in the range of 20-50% by 2030. The developments in ammonia refrigeration will mostly focus on safety advancements; such as ammonia charge reduction, as well as the renovation of ageing machines.

When comparing 2020 and 2030 expectations, it becomes clear that there is little difference in

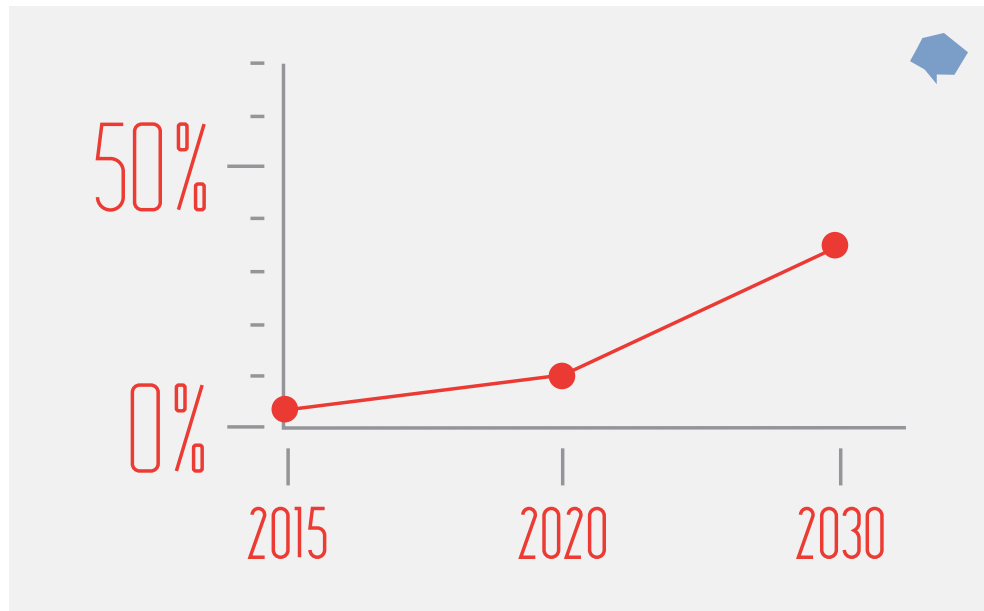

Number of respondents: 905

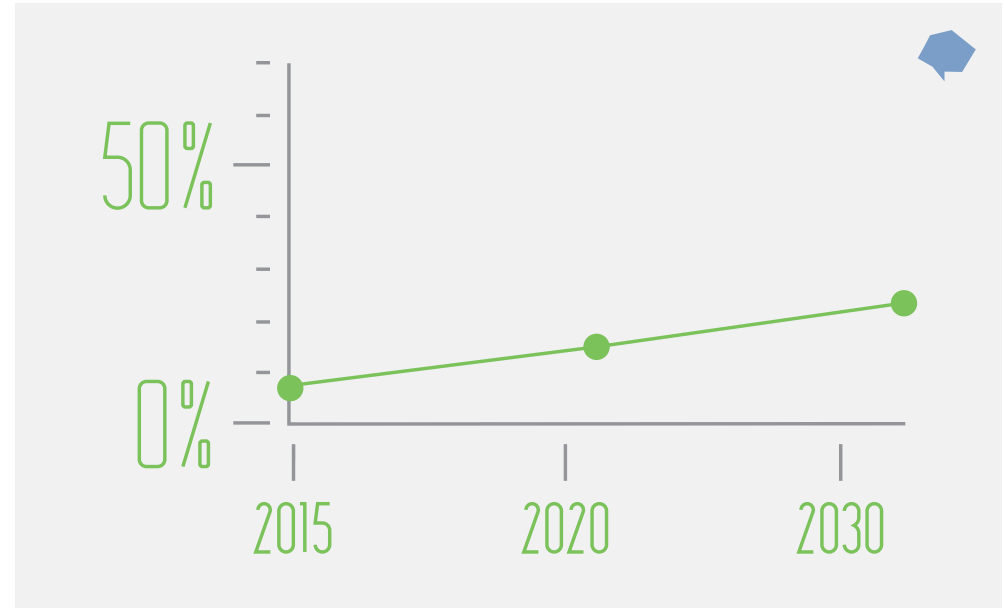

Number of respondents: 805

A MUCH LARGER ROLE FOR HYDROCARBONS ENVISAGED

In a similar vein to CO₂, the use of hydrocarbons is expected to increase exponentially over the next 15 years. The ongoing conversion process of RAC systems, that will use R290, shows the potential scope of application hydrocarbons could find if this conversion process becomes absolute in the market. Another clear application area hydrocarbons is set to consume a higher market share is in light commercial refrigeration.

As is the case in other regions around the world, the use of hydrocarbons is already common in domestic refrigeration. This is also the case in China where the use of R290 and R600 in domes-

tic refrigerators is accepted as a clear alternative. And as China's standard of living continues to increase, the demand for domestic refrigeration will continue to grow in accordance with wages and general development, with hydrocarbons continuing to serve this application.

All of these explain the anticipated leap from an expected 1%-10% market share for hydrocarbons in 2020, to an expectation of closer to 20%-50% in 2030. The contribution of government subsidies and an increase in training should give hydrocarbons the necessary boost to achieve such impressive forecasts.

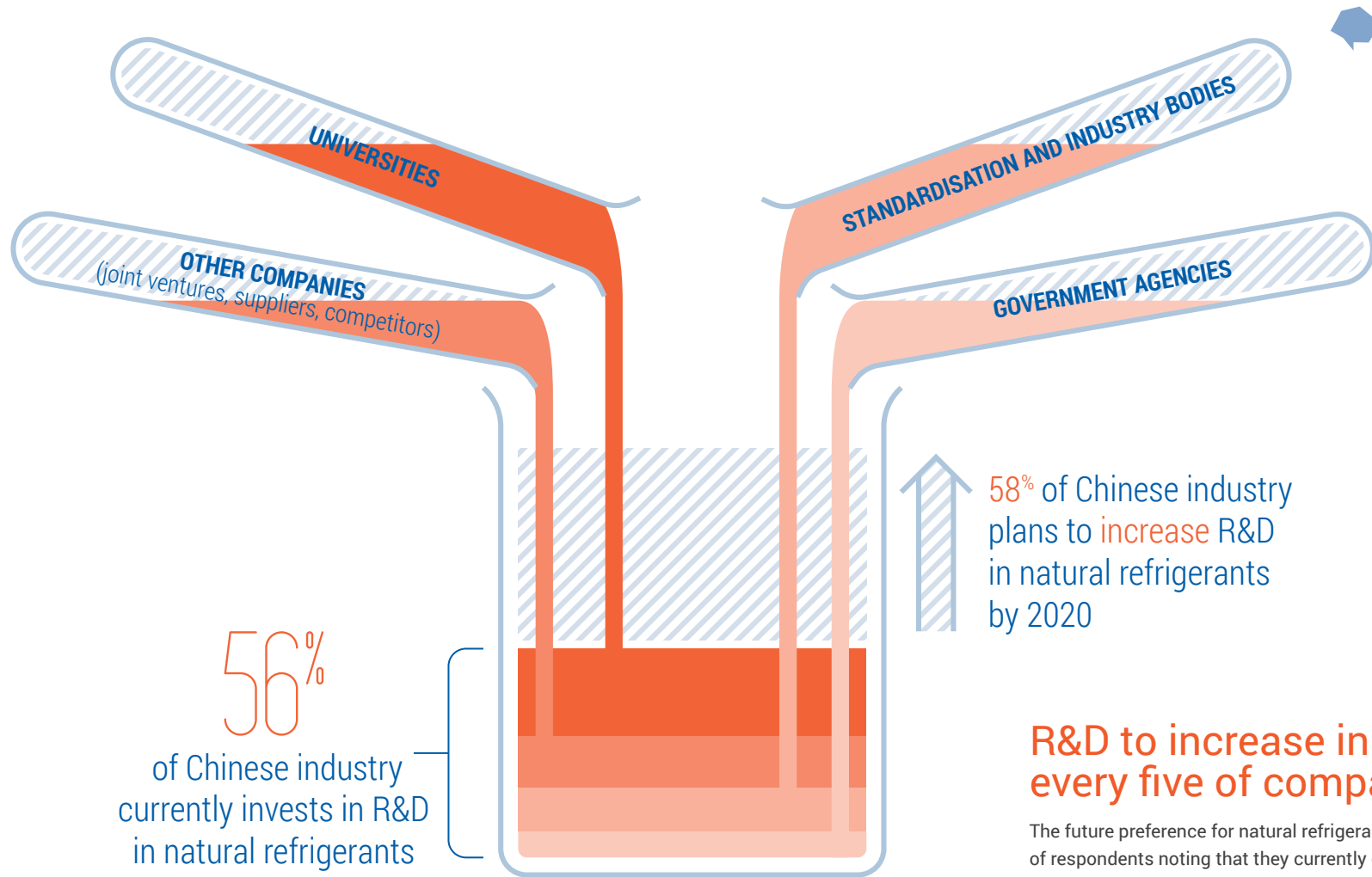

56%
of Chinese industry
currently invests in R&D
in natural refrigerants

58% of Chinese industry
plans to increase R&D
in natural refrigerants
by 2020

R&D to increase in nearly three in every five of companies surveyed

The future preference for natural refrigerants is becoming clearer to see, with 56% of respondents noting that they currently conduct R&D in natural refrigerants, and 58% forecasting that their R&D expenditure will increase by 2020. When asked with whom they currently collaborate with in R&D - allowing for more than one selection - the most frequent response was universities (43%) followed by other companies (34%). Other common collaborators were standardisation and industry bodies (29%), government agencies (18%), as well as lesser-used R&D such as were private laboratories (7%) and contractors (5%). This shows that the future development of natural refrigerant technologies in China requires cooperation from a range of sectors, such as government and research institutions.



Exclusive interviews - Market for the future

HOW DO YOU EVALUATE YOUR PROGRESS IN DEPLOYING NATURAL REFRIGERANTS IN CHINA SO FAR AND WHAT ARE YOUR PLANS FOR THE NEXT FIVE YEARS?

**Linda Zhang,
The Coca-Cola Company:**

We have been working closely with CO₂ compressor and cooler suppliers in deploying CO₂ refrigeration in China in the past 10 years. Starting from 2015, more than 90% of the cold drink equipment that we purchase for China will be commercially available HFC-free models, that are certified by The Coca-Cola Company. Thus, we are ready to go full speed in our implementation of our HFC-free Cold Drink Equipment Strategy in China and deliver our sustainability commitment.

**John Sears,
Unilever:**

We have fully rolled out hydrocarbons in our equipment for several years now in China. This means that all of our new units, which are purchased, are utilising hydrocarbons as a refrigerant.

**Holger Guss,
Metro:**

We successfully opened our first hybrid-refrigerated store in November 2014. For the upcoming new store openings and the planned remodeling under our global F-gas exit programme, this type of refrigeration should become our standard concept in China. Furthermore, we are aiming to install the first transcritical CO₂ system in China in the coming years and Metro would also like to introduce R290 operated plug-in cabinets as we have done in plenty of other countries that we operate in.

WHAT WOULD BE YOUR ADVICE TO FOREIGN COMPANIES LOOKING TO INVEST IN THE CHINESE MARKET IN THE FIELD OF NATURAL REFRIGERANT TECHNOLOGY?

**Zhong Zhifeng,
FECO:**

China is a huge market, so investment in advanced technology is encouraged and more attention should be paid to this within the market. I would recommend to prospective investors who have good technology that working with local partners will help the promotion in the Chinese market.



WHAT WILL THE CHINESE MARKET FOR NATURAL REFRIGERANT USE LOOK LIKE IN 2020? WHICH TECHNOLOGIES AND APPLICATIONS ARE THE MOST PROMISING?

Professor Shi Lin, Tsinghua University:

I predict that in 2020, due to the improvement of R&D skills within Chinese companies and the wider application of natural refrigerants in foreign markets, CO₂ in industrial refrigeration, will achieve roughly a 10% market share. CO₂ heat pump water heaters will also appear in the Chinese market and Chinese MAC companies will be developing CO₂ for use in MAC applications. In particular, high-pressure CO₂ compressors, micro channel heat exchangers and research in mixed refrigerant thermal properties, look to have a bright future. With the development of regulation for flammable refrigerants and improvement of regulation and training, ammonia in industrial refrigeration is expected to reach about a 40% market share. Hydrocarbons in small RAC applications are also expanding and becoming mainstream solutions.

Wang Xunchang, China Refrigeration and Air Conditioning Association (CRAA):

In 2020, I expect that natural refrigerants will have a significant (around 50%) market share in new projects and new products in Chinese industrial, commercial and residential applications.

Professor Ma Yitai, Tianjin University:

China is actively regulating the 19th Amendment regulation for Montreal Protocol and is phasing down HCFCs. HCFCs will be by 35% in China by 2020. At the APEC meeting held in Beijing in November 2014, China and US announced that they will work together on phasing down HFCs. These two decisions will have important impacts on alternative refrigerants for HCFCs (R22 and R123) and HFCs (R134, R407C, R404A and R410A).

China is a large producer of room air conditioning (RAC) units and the phasing out of R22 in RAC it already finished in some production lines, with conversion to R290. In Commercial air conditioning and larger applications such as in chillers and water source heat pumps using natural refrigerants such as ammonia, hydrocarbons and CO₂ are still in the research stage and I would not expect them to come to market before 2020.

When building heat pump facilities, ammonia, hydrocarbons and CO₂ can all be used as a refrigerant. For safe usage in residential applications, CO₂ is suitable for heat pump water heaters. However, China has not yet commercialised CO₂ compressor production and components, such as valves that can be used with CO₂. Therefore,

CO₂ heat pump water heaters have not achieved scaled production. Outside of China however, R290/CO₂ cascade systems in supermarket display cabinets are growing well and this technology is likely to be applied in China by 2020.

Professor Yang Zhao, Tianjin University:

The three major factors that would influence natural refrigerant market trends is first, the development of technology as currently there is insufficient technology, second, a bettering of the policy climate as there still remains some barriers in this respect and last, the development of mixed refrigerants. All the three factors have the potential to change the market, so it is difficult to predict the market accurately. But without a doubt, for natural refrigerants, to lower the risks for its flammability by reducing the charge amount, there needs to be more development.



WHAT DO YOU THINK WILL BE THE MARKET FOR NATURAL REFRIGERANTS IN YOUR AREA OF EXPERTISE BY 2020? WHICH OTHER APPLICATION PROMISES THE HIGHEST POTENTIAL FOR NATURAL REFRIGERANTS IN CHINA?

Nobuo Yoshida, Panasonic:

While it is difficult to provide a detailed market forecast for 2020, I believe the main areas of development will be in heat pump water heater and small-scale refrigeration equipment. Take the example of heat pump water heaters, sales in the Japanese market are around 500,000 units every year. This is interesting for China as the potential market size for residential heat pump water heaters is much larger than Japan's and the market is only just beginning. But no matter the size of the market or the development speed, this market is worthy of expectations. Similarly, with the increasing attention on environmentally friendly refrigerants from international chain supermarkets and the food industry, CO₂ as a refrigerant in small-scale refrigeration equipment is gradually becoming more mainstream.

Jefferson Li, Haier-Carrier:

By 2020, we believe that more and more food retailers and cold storage operators will adopt CO₂ systems. At this point, we do not see other natural refrigerants having the same potential impact as CO₂ within the commercial and industrial refrigeration sectors.

Stephan Luerssen, Bitzer:

In 2020, we believe natural refrigerants will play a much more important role than they currently do. Particularly in CO₂ applications, which can be applied in both commercial refrigeration and heat pump applications. China is in the middle of phasing out R22, which is still widely used and is also part of the international political discussions about reducing CO₂ emissions. So different refrigerants and system configurations for refrigeration and air conditioning will be tested and applied. This is similar to what happened in Europe a few years ago when the discussions about reduction of GWP started. Also in Europe, we saw a lot of different solutions and we expect to see the same in China in the coming years.

Frank Xia, Carel:

In the future, China's market will focus more and more on CO₂ technology. Especially in the case of rack applications, which are experiencing increased demand from logistic centres, cold storages and heat pump applications. The reduction of the leak of knowledge combined with the decrease of investment costs will further boost demand from local markets.

An Jingai, Danfoss:

If the related regulations can be released on time, there will be a huge potential in the Chinese market for natural refrigerants. For instance, in the field of refrigeration, hydrocarbons in domestic and light commercial refrigeration will prosper, ammonia will be the major refrigeration in industrial refrigeration and CO₂ will also be applied in some commercial and industrial refrigeration. In air conditioning, hydrocarbons will be increasingly applied in domestic room air conditioning.

Massimo Casini, Dorin:

Taking into consideration the Chinese authorities' new low-carbon footprint emission policy and their determination to reduce pollution, we are expecting a very rapid development of natural refrigerants. We believe CO₂ will be the first choice thanks to its safety and volumetric efficiency characteristics as well as its extremely low cost and availability. The increased attention on natural refrigerants also increased the attention on the use of other natural fluids even if the recent accidents occurred at some ammonia installations might have had a negative impact on the use of this refrigerant for non-industrial systems.

Lin Rujie, Snowman:

We expect that the use of natural refrigerants in industrial refrigeration will grow in China by 2020 due to the speed-up of the HCFC phase-out plan and the policy support from the Chinese government as well as associations promoting natural refrigerants. In addition to this, there is a huge potential for development in the Chinese market due to the current economic gap between some regions in China that has created a technology gap. Even in economically developed regions, there is still room for technological improvement compared to developed countries. Lastly, natural refrigerants are cheap, easy to obtain and an environmentally friendly solution with high energy efficiency. Besides industrial refrigeration, the use of ammonia in high-temperature heat pumps and heat pumps for air conditioning by 2020 are areas to keep an eye out for.

Tommy Angback, Alfa Laval:

CO₂ will be very slowly introduced in the commercial refrigeration market but CO₂ will come – mainly in cascade systems using HCFCs/HFCs.



Exclusive interviews - Action plan for faster introduction of natural refrigerants

IF YOU HAD TO FORMULATE AN ACTION PLAN FOR YOUR ORGANISATION TO BRING NATURAL REFRIGERANT TECHNOLOGY FASTER TO THE CHINESE MARKET, WHICH ACTIONS WOULD YOU PUT ON TOP OF THE LIST?

Stephan Luerssen, Bitzer:

- 1) Our first step is to provide enough training to people in this country and the industry so that they can design, install and apply NR-based systems professionally and safely.
- 2) The next step is to offer the right products for the local requirements and possibly adapt the product portfolio for the sizes of systems and system configurations used in China. In close cooperation with our partners, we will work on the right system designs and strategies for the various applications.
- 3) The third step is to further develop and enhance our service network so that we are ready to embrace the new challenges of NR-based systems.

Holger Guss, Metro:

In our opinion we have got a reasonable road map to implement natural refrigerants to our Metro stores. We believe that the use of natural refrigerant will be established in China, but like in many other countries, it will not happen overnight.

Linda Zhang, The Coca-Cola Company:

- 1) Engage with government agencies and industry peers to promote the application of our HFC-free system designs and CO₂ technology.
- 2) Optimise the design to lower the incremental cost, particularly for smaller sized cold drink equipment (50-250 L).
- 3) Develop solutions for smaller capacity cold drink equipment (<50 L).

Frank Xia, Carel:

- 1) Coaching. We continuously provide workshop and training session internally and externally to our customers/partners.
- 2) Flexibility to adapt our solution according to different customer needs.
- 3) To be able to do analysis on the system's safety at any time and from any location.

Massimo Casini, Dorin:

- 1) Continue the promotion of CO₂ technology in large companies and universities.
- 2) Create a well-skilled team located in China.

R. Abel Gnanakumar, Emerson Climate Technologies:

- 1) As a global company, we can use the experience and maturity of our foreign projects as a reference to help domestic contractors and end users to build or retrofit their new natural refrigerant systems
- 2) Introduce the relative products that fit the natural refrigerant system and provide technical and product support to the domestic market
- 3) Cooperate with the national department to improve the relevant standards and regulations created to help accelerate the implementation of the national policy process.

Nobuo Yoshida, Panasonic:

- 1) Provide 300W-7500W closed type compressors that can be widely applied into the market to meet clients' needs.
- 2) Bring a 1500W residential heat pump water heater compressor to the market and increase use of 7500W commercial water heater and commercial refrigeration.
- 3) In the freezing and cooling market, produce a complete product and bring it to the market.

Lin Rujie, Snowman:

- 1) Strengthen communication, particularly with the international community and with environmental protection organisations to increase the number of staff and engineers knowledgeable in natural refrigerants and its technology.
- 2) To define natural refrigerants (ammonia, CO₂, R290, air and water) as the main technology route for the company.
- 3) To expand Snowman's technological advantage in natural refrigerants to increase the product range of its compressors, including accompanying components and heat exchangers.

Jefferson Li, Haier-Carrier:

- 1) Provide the best CO₂ systems, solutions, and services to our customers to support their transition to CO₂ systems.
- 2) Provide CO₂ training to our customers, especially their engineers, installers and service technicians.
- 3) Work with the government to obtain more regulatory support to encourage the adoption of CO₂ based technology in China.



IF YOU HAD TO FORMULATE AN ACTION PLAN FOR RESEARCH INSTITUTIONS TO BRING NATURAL REFRIGERANTS FASTER TO THE CHINESE MARKET, WHICH ACTIONS WOULD YOU PUT ON TOP OF THE LIST?

Professor Ma Yitai, Tianjin University:

For research institutions, in refrigeration and the heat pump sectors, China currently does not possess strong institutions working on the development of advanced technology. Most companies introduce key technology or products (such as compressors) from abroad and utilise China's advantage of lower wages to achieve large-scale production. Therefore, I suggest asking foreign CO₂ compressor manufacturers to build production bases in China, so they can reduce the production costs. The second suggestion I have is to build component production bases for CO₂ refrigeration to produce different heat exchangers, electronic expansion valves and various control valves and meters. Thus different assembly plants can choose their products to produce different types of CO₂ refrigeration products and to participate in CO₂ refrigeration and heat pump installations. The last advice I have is to conduct training for CO₂ transcritical systems and promote the HVAC&R industry to write training material and to train teachers. In two to three years time, it is expected we would have a professional team who understand CO₂ refrigeration and can operate systems safely and understand the features of main components so as to be able handle both repair and maintenance.

Professor Shi Lin, Tsinghua University:

- 1) More analysis and research on natural refrigerants, their application trends and international alternative technologies.
- 2) Emission reduction potential analysis for natural refrigerants.
- 3) Create a reasonable alternative plan and natural refrigerant development plan.

Wang Xunchang, China Refrigeration and Air Conditioning Association (CRAA):

I hope that the Montreal Protocol can pass its plan for the HFCs phase-down amendment. Meanwhile, the Foreign Economic Cooperation Office of Ministry of Environmental Protection and CRAA can try to create an alternative policy and alternative technology development plan. In addition to this, I hope that European, American and Japanese companies in the HVAC&R industry can do business with China, with a mutual relationship which helps transfer technology to Chinese companies.

Professor Yang Zhao, Tianjin University:

- 1) Strengthen the research on flammable refrigerants' application base.
- 2) Ensure public education to inform the public about natural refrigerants and also about misconceptions regarding natural refrigerants.
- 3) To fully understand whether the Chinese market is prepared enough to introduce flammable natural refrigerants.



IF YOU HAD TO FORMULATE AN ACTION PLAN FOR OTHER STAKEHOLDER GROUPS TO BRING NATURAL REFRIGERANTS FASTER TO CHINESE MARKET, WHICH ACTIONS WOULD YOU PUT ON THE TOP OF THE LIST?

Linda Zhang, The Coca-Cola Company:

- 1) Seek sponsorship from government agencies and/or NGOs to promote our HFC-free system designs and CO₂ technology, i.e. lobby for incentive policies.
- 2) Engage with other stakeholders to encourage industry peers to apply CO₂ refrigeration and Coca Cola's system designs, i.e. share positive learning experiences and advice on CO₂ refrigeration.
- 3) Engage with our customers to jointly promote HFC-free CDE.

Wang Xunchang, China Refrigeration and Air Conditioning Association (CRAA):

I hope shecco can utilise this study to grasp some basic understanding about the natural refrigerants market in China in order to be the bridge between China and Belgium, and more widely, China and Europe. With good communication, shecco will be able to understand more about the industry and get more suggestions to cooperate.

Professor Ma Yitai, Tianjin University:

If this suggestion is for companies that are engaging in the production of CO₂ refrigeration and heat pumps, I can give three pieces of advice:

- 1) If there are large funds available to the companies, then the production of CO₂ compressors is very attractive, as CO₂ as a refrigerant is likely to remain a consistent trend for the future. Once the compressor manufacturers have formed large-scale production, it will form the basis of the market
- 2) They can enter from traditional products, such as CO₂ heat pump production and to form set packages for compressor, heat exchangers, components and refrigerator packages.
- 3) I suggest these companies set up their own R&D centre. If they do not have the base to set up, they can work with us. My colleagues and I can participate in solving technical issues.

Tommy Angback, Alfa Laval:

- 1) Share information on references and availability of appropriate technology in china.
- 2) Introduce clear regulations
- 3) Provide government subsidies to encourage natural refrigerants

Stephan Luerssen, Bitzer:

- 1) Have economically sound policies to promote NR-based systems
- 2) Encourage the development of key components, research and manufacturing in China – for example, through any kind of tax refund for NR research and applications for manufacturing.
- 3) Establish more hands-on regulations and instructions/guidance for applying NR-based systems, and enforce adherence to regulations to ensure the safety of such kinds of applications.

Massimo Casini, Dorin:

- 1) Advertising/information to the market about the worldwide trend for low-carbon emission tendency and on the environmental friendly alternative solutions.
- 2) Set up prototypes of the most utilised systems using natural refrigerants to demonstrate their performances/reliability and competitive running costs analysis
- 3) Collaborate with the authorities to be in line with new national regulations.

John Sears, Unilever:

My action plan for a company looking to bring natural refrigerants technology to China would be three-fold. Firstly, I would reiterate the importance of gaining the right service partner. Secondly, a controlled maintenance history is a must; and thirdly, have a supply of standardised spare parts to avoid potential problems in the future.

**Lin Rujie,
Snowman:**

- 1) Government and industry associations can provide the lead to promote policies that encourage natural refrigerant technology in refrigeration and air conditioning fields with favourable policies for the research and trailing process.
- 2) Strengthen end user knowledge about natural refrigerants to promote the advantages and necessity of natural refrigerant-based technology.
- 3) Create a national demonstration project to lead and promote natural refrigerant development and its use in applications in China.

**Professor Shi Lin,
Tsinghua University:**

- 1) Prepare for the future changes by having a good technical capability.
- 2) Help inform end users of the new refrigerant technology to allow for a smoother transition.

**Jefferson Li,
Haier-Carrier:**

- 1) Influential food retailers should speed up their CO₂ adoption plans
- 2) Governments should speed up the phase out plan for HCFCs as well as the adopt regulations that would encourage the adoption of natural refrigerants
- 3) Manufacturers should strengthen their training of installers and service technicians in CO₂
- 4) Suppliers should speed up the acquisition and provision of CO₂ components within China e.g. compressors, valves etc.



Exclusive interviews - Policy for the future

HOW DO YOU PREDICT THE REGULATION ON HFCS IN CHINA TO LOOK LIKE UNTIL 2020?

**Professor Ma Yitai,
Tianjin University:**

The Chinese and American government will strengthen the cooperation on phasing-down high-GWP HFCs. The EU and North America are starting to regulate HFCs and China might have to learn from the experiences of the EU. At this year's Paris climate summit, there might be detailed regulations ready for HFCs and I believe China will follow this regulation.

**Wang Xunchang,
China Refrigeration and Air
Conditioning Association (CRAA):**

It will depend on the Foreign Economic Cooperation Office of Ministry of Environmental Protection and CRAA's as to whether China can avoid the use of third generation fluorinated refrigerants following the transition away from CFCs. They could realise that phasing out high-GWP HFCs is unavoidable for China if they wish to leapfrog other developments and go straight to the use of low-GWP refrigerants. I expect in the current global climate, that around 2016 the Chinese Government will create a replacement policy and the necessary technical adjustments.

**Professor Shi Lin,
Tsinghua University:**

China is one of the major refrigerant users and producers. Due to the demands of economic development, China's HVAC&R industry will still maintain its developmental speed. However, the major refrigerant used in China is still HCFCs and the consumption of HFCs refrigerants is starting and is likely to increase. In the future, China will need to pay attention to international HFC phasing-down development goals in the background and to actively follow international R&D progress, to eventually phase out the use of HFCs.

**Professor Yang Zhao, Tianjin
University:**

The policy measure that may be created might be to partially phase down'. In the earlier stage of this policy - around 2020 - it should either phase out high GWP HFCs or have a schedule confirmed for phase outs. In the calculation for greenhouse effect parameters, we can take parameters such as GWP (global warming potential), TEWI (total equivalent warming impact) and LCCP (life cycle climate performance).



DO YOU EXPECT CHINA TO BECOME A WORLD LEADER IN ANY SPECIFIC NATURAL REFRIGERANT TECHNOLOGY?

Professor Ma Yitai, Tianjin University:

The production capacity of China's HVAC&R sector is already the highest in the world, but China is yet to acquire the most sophisticated technology in the world. The production of components requires advanced technology, such as compressors, electronics and low-GWP refrigerants. However, the core technology is all produced outside of China. But we can see that China is making great progress in this deficiency, such as the NH₃/CO₂ system produced by a Chinese manufacturer that is being exported abroad. Through the wide application of CO₂ as a refrigerant, from subcritical to transcritical systems, from large volume to middle and large volume, it can craft the refrigeration industry with Chinese idiosyncrasies and leading world trends. I believe that technologies like this will lead the global trend and if China can catch up fast, it might be areas such as natural refrigerants, in particular CO₂ where China will be the world leader. Of course, China also has the distinct advantage with regards to human resources and large low-cost steel, as well as large domestic market, meaning both supply and demand are well served.

Professor Shi Lin, Tsinghua University:

China could be a leader in the use of CO₂ in refrigeration equipment and the use of HCs in small RAC applications. But this depends on China's commitment to emission reductions, its development in safer technology and also its increased investment in R&D for key technologies, in addition to its cost advantages.

The key technologies that have a good development potential will be flammable refrigerants, flame retardant inert technology, combustion explosion control, and explosion protection technologies as well as heat exchangers with small diameter tubes, lower refrigerant charge technology and cryogenic systems using atmosphere as refrigerant. In addition to these, the use of air as a refrigerant in low temperature system applications and super heat pump technology, will also begin to appear.

Professor Yang Zhao, Tianjin University:

As the largest producer and consumer in the world, China has a huge responsibility to replace HCFCs. Through this replacement of HCFCs, it is difficult to know whether China will become a world leader as it would be dependent on the development of other countries. But the size of China's potential domestic market would be a huge advantage to supplying the large demand for alternative refrigerants abroad.

China's advantages also include its comprehensive ability in cost-controlling, its technological ability, its production and innovation, its industrial scale, amongst other factors. While China is not strong or a leader in every aspect, its comprehensive ability is very impressive.

Wang Xunchang, China Refrigeration and Air Conditioning Association (CRAA):

I hope that the Chinese industry can be honest and humble and absorb new technologies. At the same time, I hope that the foreign media can convey the information of the Chinese market to the general public correctly and not an 'idealised' image of Chinese technology. The only advantage for the natural refrigerants market in China is the size of the market, its intrinsic large demands and the urgency to catch up with technological advances that are occurring around the world.

Key applications for natural refrigerants in China

Industrial refrigeration

Introduction

Natural refrigerants in the Chinese industrial refrigeration industry are entering an important phase due to the rapidly increasing development of cold storage and cold chain infrastructure in China, as well as the increased attention on CO₂ as a refrigerant in industrial applications. Meanwhile, even though there is a focus on improving energy efficiency and upgrading to advanced technology and management, there are still challenges remaining for natural refrigerants within the industrial refrigeration market in China today.

Besides this, the long-term task still remains: to educate personnel to handle and manage the systems effectively and safely. This process would involve collaboration between the government, the industry and research institutions to educate the employees to meet the rapid demand in industrial refrigeration. In addition, more policy support from the government would help the industry to gain a better awareness of natural refrigerants and the provision of subsidies would encourage end users to invest in more energy efficient and environmentally friendly natural refrigerant solutions.

Ammonia is a standard refrigerant used in industrial refrigeration facilities and currently there are more than 30,000 end users in China using ammonia as a refrigerant. The rapid development of ammonia in large-scale refrigeration systems does not match the amount of trained personnel able to handle such technology. As a result of this, safety issues regarding ammonia usage in cold storage has attracted a great deal of attention from the government and the industry since 2013. The industry is gradually taking steps to ensure higher safety to comply with necessary requirements. In particular, reduction of ammonia charge and introduction of ammonia/CO₂ systems in industrial refrigeration, is gaining ground in China.

Data collected from leading manufacturers of natural refrigerant-based industrial refrigeration systems indicate that there are at least 30 projects in China that use CO₂ as a refrigerant in secondary or cascade systems, while construction of additional four projects is currently underway.

Currently there are more than 30,000 companies in China using ammonia as a refrigerant.

By 2017, China will likely surpass the capacity of the US cold chain, currently at 115 million m³ of space.

CO₂ industrial refrigeration projects

34 PROJECTS ACROSS CHINA USING CO₂ AS A REFRIGERANT BY DECEMBER 2015

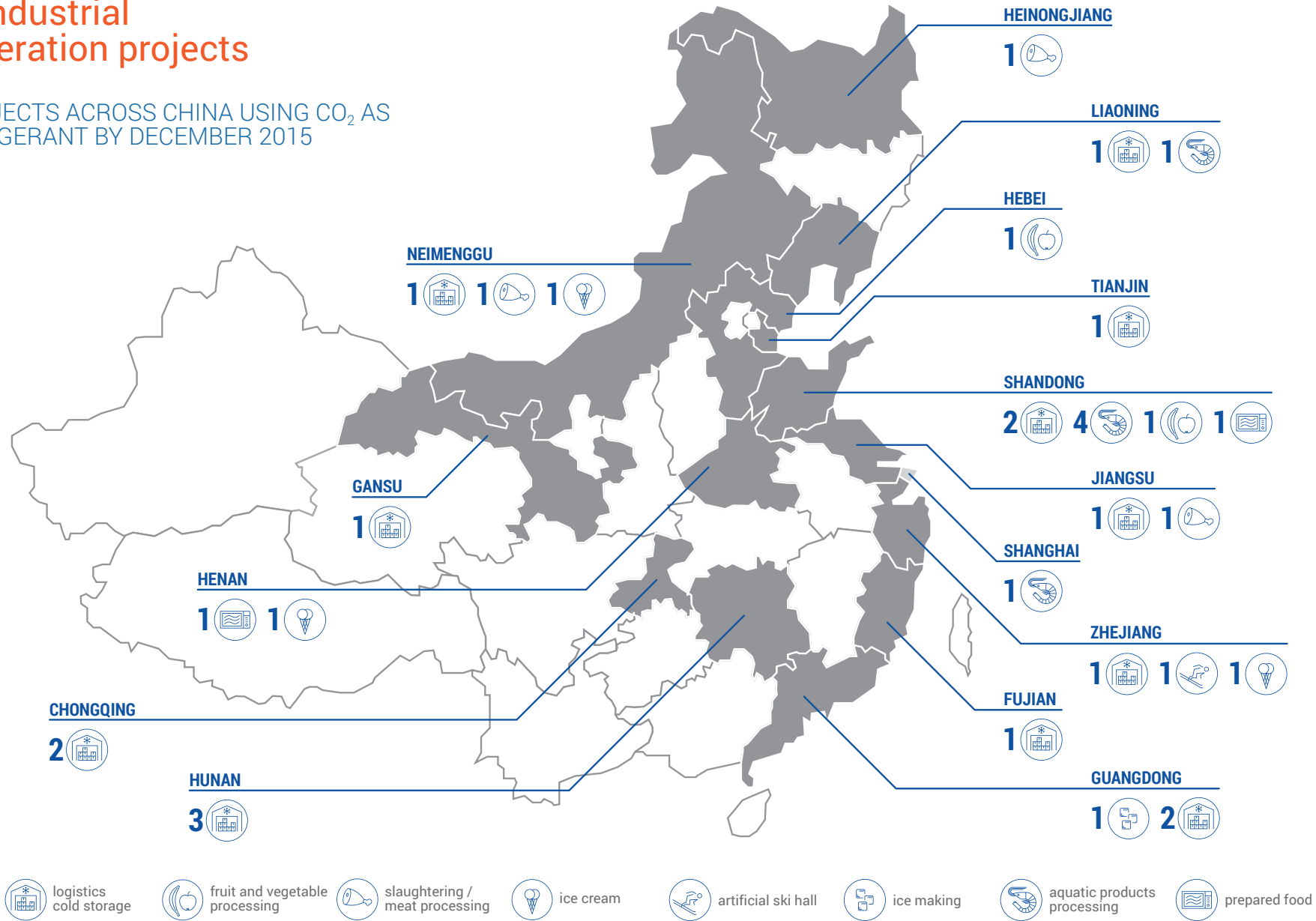

- logistics cold storage
- fruit and vegetable processing
- slaughtering / meat processing
- ice cream
- artificial ski hall
- ice making
- aquatic products processing
- prepared food

China's cold storage experiencing rapid growth

In 2014, China had the third largest cold storage capacity in the world, after India and the U.S., with 76 million m³ of space. The increase in cold storage construction in China has reached an all-time high as a result of urbanisation and change of lifestyle in cities. During 2008-2014, China was estimated to have experienced 34.67% in compound annual growth rate (CAGR) in refrigeration warehouse capacity. By 2017, China will likely surpass the capacity of the U.S. cold chain, which is currently at 115 million m³ of space.

The key driver for the food cold storage growth in China is the improvement of food safety and reduction of food waste as the demand for food rises. In order to meet the rapid demand for food cold storage infrastructure, the National Development and Reform Commission published the Agricultural Cold Chain Logistics Development Plan in 2010. The plan aimed to speed up the construction of the cold chain for food, including

meat, seafood, vegetables, fruits and eggs to be processed and stored in a cold environment. Until 2015, the plan aimed to increase the construction of cold storage by 10 million tonnes from the capacity of 8.8 million tonnes in 2010. The plan was devised to improve cold chain circulation rates for produce, meat and seafood by 20%, 30% and 36%, respectively, by 2015; and increase the refrigerated transportation rate by 30%, 50% and 65%.

The expansion of cold chain logistics is expected to continue its rise in parallel with increasing concern over food safety in China. In 2014, the government revised China's Food Safety Law in order to increase the quality of food.

Meanwhile, in the midst of this growth, the industry is also facing the crucial challenge to ensure proper refrigeration management procedures are adhered to.

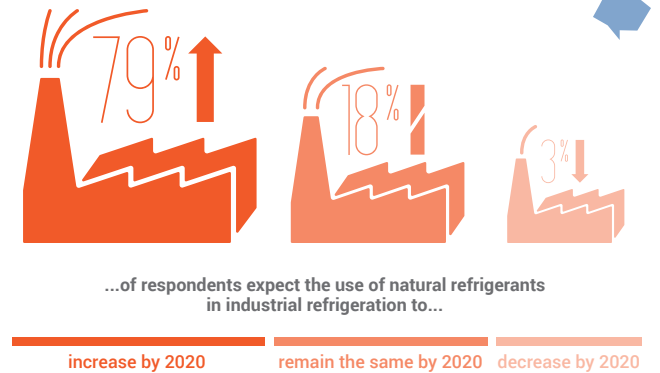

Number of respondents: 536

Industrial refrigeration to become a hotspot for use of natural refrigerants

When asked to predict the market for natural refrigerant technologies in industrial refrigeration by 2020, 77% of survey respondents predicted that it will increase either 'significantly or slightly,' 19% think that the market will remain the same as today and only 4% considers that it will decrease, either slightly or significantly.

The use of ammonia and CO₂ in industrial refrigeration is already a well established trend. In the face of the HCFC phasedown and the efficiency benefits of NH₃ and NH₃/CO₂ systems, the trend is set to continue and is set to take over China's rapidly expanding cold storage chain as well.

Huge potential for energy savings in state-of-the-art systems

The growth of cold storage in China is not always accompanied with the implementation of refrigeration best practices. In the majority of cold storage facilities in China today, over 70% of the energy is used for refrigeration. Due to the inefficiency of systems, this leads to high energy bills for operators. With an end-view of improving the energy performance in the cold storage sector, the government encourages the industry to move towards improved energy efficiency through incentives in its National Energy Source 12th Five Year Plan.

With increased knowledge and experience of control systems in industrial refrigeration, there

exists a huge potential to enhance energy efficiency in China's cold storage sector through the transition to state-of-the-art systems. One such example is the optimisation of controls in industrial refrigeration systems, as the technology offers significant potential for energy saving in large cold storages. Areas of improvement also include all the key components in an industrial refrigeration system, including: the condenser, evaporator and compressor. It is estimated that with more energy efficient technology users would see at least 20% energy saving compared to traditional solutions, while the potential for energy efficiency improvement promises a very short return on investment.



Number of respondents: 516

Use of ammonia and CO₂ in industrial refrigeration rated highly

In the survey, both ammonia and CO₂ in industrial refrigeration were rated extremely highly in current business & policy climate. Ammonia and CO₂ in industrial refrigeration are ranked 2nd and 3rd respectively out of 11 applications listed, and only 'hydrocarbons in domestic refrigeration and freezer', a standard application for the use of natural refrigerants in China, is ranked higher.

This shows the confidence the industry has in ammonia and CO₂ as well as a clear message that natural refrigerants can be the dominant refrigerants in industrial refrigeration applications.

Ammonia safety becomes a high priority for the industry

Ammonia has been successfully used as a refrigerant in China for more than 60 years and is widely applied in large-scale refrigeration systems all over the world. Since ammonia is toxic, it is crucial to ensure proper operation, maintenance and effective control of an ammonia refrigeration system.

The lack of professionally educated and trained personnel operating in ammonia facilities was identified as one of the main factors contributing to ammonia refrigeration accidents. In the first 50 years of ammonia use there were few casualties related to the use of ammonia thanks to operator education, which ensured a thorough understanding of the refrigeration system and the ability

to maintain and repair ammonia refrigeration systems. This has rapidly declined in the last few years. In the evaluation of 70 ammonia accidents in China over the past five years, almost half of these occurred as a result of ammonia release, due to a failure in the maintenance operations, while close to 40% of accidents resulted in a fire due to fire regulation violation or improper use of materials.

The focus of the industry on improving safety of ammonia industrial refrigeration facilities in recent years has resulted in technology developments to reduce ammonia charge, as well as in automatic control systems that lower operational mistakes while reducing cost.

Most potential for natural refrigerants in China by

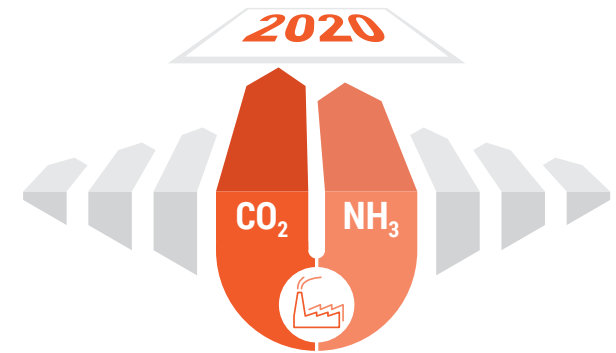

Number of respondents: 476

Future will see a cascade of natural refrigerants

When asked in the survey about which application sectors have the most potential by 2020, CO₂ in industrial refrigeration is ranked second and ammonia in the same sector third out of 11 applications, again, only after hydrocarbons in domestic refrigeration, which will continue to dominate.

CO₂/NH₃ cascade systems reduce ammonia charge, increase efficiency, are environmentally friendly and reduce cost. Therefore, it's a no-brainer that CO₂ and NH₃ in industrial refrigeration are seen as first and second best future applications, respectively, for natural refrigerants in the Chinese market.

Bright future for NH₃/CO₂ systems in China

The development of NH₃/CO₂ secondary and cascade refrigeration systems has been gaining popularity since 2013, when the technology was developed and tested by a Chinese manufacturer. A NH₃/CO₂ cascade system can effectively reduce the ammonia charge by as much as 90% compared to an ammonia-based one. This makes it possible to apply natural refrigerant-only systems even for large-scale cold storage facilities, where a direct ammonia systems are not feasible due to charge limitations. In addition to this, in a NH₃/CO₂ system, ammonia is confined to an engine room, with limited access for cold storage staff; increasing safety and lowering the risk of food contamination.

According to market data gathered from leading Chinese industrial refrigeration manufacturers, CO₂ as a refrigerant has been applied in more than 30 projects in China by the end of March 2015. In addition, at least four installations are

under construction in the first half of 2015. The installations vary from ice making facilities and cold storages through to meat, aquatic products and prepared food processing, to ski halls and ice cream production facilities. In the majority of facilities, CO₂ is used as a secondary coolant or as a low stage refrigerant in cascade systems with ammonia. A cascade refrigeration system developed by Chinese manufacturers can supply temperatures between 0°C and -52°C.

The use of the two natural working fluids combines the advantages of ammonia and CO₂, as the latter has good properties, in particular at low temperature, but is not a substitute for ammonia. An ammonia/CO₂ system provides advantages including low capital costs and higher efficiency, and it is one of the most suitable approaches for an environmentally friendly solution in situations where a direct ammonia system is not feasible.



Popularity of NH₃/CO₂ technology is a global trend

In North America, ammonia is used in over 95% of large industrial applications in food and beverage processing and storage. The case is the same in Europe where ammonia enjoys a high share of deployment in several European countries, as it is recognised as being economically viable, environmentally friendly and very energy efficient. As large facilities around the world are subject to increasingly stringent safety regulations, pressure is being placed on companies to reduce the size of ammonia refrigerant charges. Owners of large industrial plants are starting to use ammonia in conjunction with a secondary refrigerant - such as CO₂. In Japan, 10% of new cold storages systems installed from 2008-2012 use a NH₃/CO₂ technology. Such a system is particularly popular in larger capacity storages.

Focus on energy savings at the heart of China's national strategy

In China's rapidly changing economic landscape, energy efficiency has become key for the national strategy on sustainable development. In December 2011, the 12th National Energy Technology Plan 2011-2015, focused on "safety, high efficiency and low carbon emission" as the direction

for future energy technology development. More recently in June 2014, the State Council released the 'Energy Resource Development Strategic Action Plan 2014-2020'. The plan focuses on energy savings and carbon emission reductions to transform energy development to a cleaner

and greener one and by increasing technological progress in energy efficiency. China's competitiveness will also be positively impacted with this shift to energy efficiency.

Montreal Protocol kick started the development of NH₃/CO₂ system in China

As part of China's HCFC Phase Out Management Plan under the Montreal Protocol, a demonstration project of an NH₃/CO₂ cascade refrigeration system was implemented in China, through collaboration between the Foreign Economic Cooperation Office, the Ministry of Environment Protection of China and the United Nations Development Programme (UNDP). The objective was

to establish the suitability of the technology as a viable replacement for R22 in the manufacture of two-stage refrigeration systems for cold storage and freezing applications.

In the demonstration project, the existing product lines of compressor and pressure vessels were modified to meet the industrial production capac-

ity of NH₃/CO₂ cascade refrigeration systems. In 2013, the project was successfully completed, providing an environmentally safe and cost-effective alternative, enabling replication of the technology in similar applications in China's industrial refrigeration sector.

Safety codes – a precondition for safe use of ammonia and CO₂ in cold storage

Until recently, the lack of national safety standards was seriously impeding the introduction of ammonia refrigeration systems as many local governments and end users were reluctant to adopt the technology due, to potential safety risks. In China's fast-growing cold storage construction this led to a huge amount of missed opportunities for the manufacturers of ammonia systems.

Therefore, the adoption of the Safety Code for Cold Stores (GB28009-2011) at the end of 2012 alleviated a major market and policy barrier, and paved the way for the safe use of ammonia as a refrigerant in China's cold storage infrastructure. The standard sets out detailed safety rules and principles for cold storage design, construction, operation and maintenance management. It applies to both direct and indirect refrigeration systems using ammonia and fluorinated refrigerants

(HFCs and HCFCs) and includes detailed rules regarding safety management for the machinery room, refrigeration equipment and systems, refrigerating compressors and other auxiliary refrigeration equipment. In addition, according to China's Code for Design of Cold Stores (GB50072-2010), facility owners must carry out regular system maintenance to ensure the refrigeration system is in good condition and minimise the risk of ammonia leaks.

Similarly with the increased focus on using CO₂ as a secondary coolant or as a low stage refrigerant in cascade systems with ammonia, there is a need for a national safety standard that will pave the way for in-

creased use of such technology. A standard applicable to CO₂ compressors used in industrial refrigeration has been in place since 2012. Nevertheless, safety standards related to the design of cold storages using CO₂

as a refrigerant are currently in the process of being drafted and are expected to be completed in 2015.

Imposing stricter controls on ammonia facilities

In September 2013 the State Council Administration of Work Safety launched an initiative to improve safety in facilities using ammonia as a refrigerant. The initiative requires cold storages that use ammonia without related certification and basic operation conditions for safe operation, to shut down. Those that do not meet the safety requirement design in refrigeration equipment must stop production until approved by related

government departments.

In addition to this, the initiative required cities and regions with a large number of companies using ammonia refrigeration to organise training programmes for personnel in charge of safety and operation departments in cold storages. In particular, the programme trains personnel in Code for Design of Cold Stores (BG50072-2010), Safety Code of Cold Stores (GB28009-

2011) and regulations on handling dangerous chemicals in equipment management and fire management.

These steps will pave the way towards a safer use of ammonia refrigeration in China, which is vital if the country is to meet the rapid growth in the cold storage industry using natural refrigerants.

Ammonia training – key to ensuring safety

In September 2013, the State Administration of Work Safety published training material for ammonia refrigeration. The material provides a comprehensive overview of the basic knowledge regarding ammonia as a refrigerant and refrigeration system design, as well as design safety measures, management, operation, control and emergency measures on a daily basis.

Since 2013, there have been a series of training programmes organised by city and township governments titled 'Administration of Work Safety', which target companies using ammonia, government inspection officers and firemen for safety training and the inspection process for ammonia in industrial refrigeration. State Administration of Work Safety rewards certificates to those that successfully pass the test in the training programme.

In addition to government initiated training courses, a series of training programmes have been organised by leading system manufacturers and training institutes to educate end users about ammonia industrial refrigeration systems.

Safety training in industrial refrigeration will require a long-term investment from the government, system manufacturers and end users to observe the regulation in system design, personnel training and daily management process. The rapid increase in industrial refrigeration requires a speeding up of the education framework to catch up with the needs in training personnel to handle these systems on a daily basis.

Exclusive interviews - Industrial refrigeration



WHAT DO YOU THINK IS THE MAJOR MARKET TREND FOR NATURAL REFRIGERANTS IN INDUSTRIAL REFRIGERATION IN CHINA TODAY?

Professor Ma Yitai, Tianjin University:

In recent years, industrial refrigeration has been developing rapidly but there are some safety concerns due to old facilities and management issues. In 2013, some incidents occurred in the ammonia refrigeration process and these taught the industry an important lesson. The Government safety department analysed the incidents and began to regulate facilities that were not being managed properly, and the safety department also replaced old facilities with new ones as well as training people that were involved in the process. And as such, ammonia is still the major natural refrigerant being used in China today.

The introduction of CO₂ in subcritical cascade systems has just started and the corresponding components for CO₂ compressors and CO₂ heat exchangers are being developed little by little. This development is encouraging the use of NH₃/CO₂ systems and will play an important role for the development of CO₂ in transcritical systems.

An Jingai, Danfoss:

For the industrial refrigeration market, NH₃/CO₂ cascade systems are a very effective way to lower the ammonia charge as well to increase the refrigeration system's efficiency. CO₂ is also extremely efficient as a secondary fluid for medium temperature applications due to its low viscosity. As a DX refrigerant it is most efficient at low temperatures. The excellent heat transfer properties and high volumetric efficiency means that piping diameters can be reduced, whereby heat exchange becomes very efficient.

In China, all the large-scale industrial refrigeration systems using CO₂ adopt Danfoss components and solutions inside their systems. For the food retail market, Danfoss offers a complete range of CO₂ system solutions including the ADAP-KOOL® control and monitoring systems, regulation and injection valves, sensors (temperature, pressure, gas detectors), filter-driers and line components.

WHAT WOULD YOU ADVISE THE CHINESE GOVERNMENT AND INDUSTRY TO ENSURE THE SAFE USE OF NATURAL REFRIGERANTS IN CHINA?

Professor Ma Yitai, Tianjin University:

CO₂ is non-toxic and operates under high pressures. In the process of equipment production, the high pressure needs to be taken into consideration and industry standards for CO₂ equipment must be met. In the application process, equipment needs to be equipped with a pressure-monitoring device to prevent accidents.

Due to the rapid development of China's economy, and subsequently, its food cold storage technology, the existing national regulations and technology standards might not be sufficient in light of recent development trends. Experts should revise the relevant standards and regulations for ammonia refrigeration systems. Although ammonia is classified as highly toxic and a maximum charge limit is set, in reality the limit is exceeded by the storage and transportation of ammonia, which is unregulated. I suggest establishing a refrigeration safety committee across China, which should be in charge of refrigeration system safety, fire and leak prevention, as well as investigation of refrigerant-related accidents. Strengthening the knowledge of ammonia systems' safety is essential among those handling refrigeration systems, as well as among students at universities and other education institutions.

Professor Yang Zhao, Tianjin University:

The government and industry should ensure that when end users choose natural refrigerants equipment, they can rest assured that the safety risk is lower than in the case of conventional equipment. The overall advice I would give is to minimise the current risk in CO₂, ammonia and hydrocarbons technology by reducing the amount of charge and use of secondary systems.

Professor Shi Lin, Tsinghua University:

Through promotion of CO₂ in refrigeration equipment, the allocation of subsidies would help incentivise CO₂ heat pump water heater technology. For ammonia as a refrigerant, the standardisation and training of technicians can increase the adoption of ammonia. To improve hydrocarbon risk assessment in limited operation and maintenance environment, there should be an analysis of an incident probability tree.



WHAT ARE THE STEPS THAT YOUR COMPANY IS TAKING TO ENSURE THE SAFE HANDLING AND MAINTENANCE OF SYSTEMS BASED ON NATURAL REFRIGERANTS?

Stephan Luerssen, Bitzer

BITZER believes safe operation is always one of the top priorities when suggesting a system layout. To ensure this, BITZER China has invested in a first-class training centre at our new facility in Beijing, China. This leading industrial training centre will be capable of providing comprehensive hands-on training to our customers, end users, system operators and others with regards to handling and maintaining natural refrigerant based systems, including those that use CO₂. Besides internal courses, this training centre will also provide courses that people from the industry can participate in, which will train them to handle natural refrigerants in a safer and more professional way.

An Jingai, Danfoss:

Ammonia as a natural refrigerant does not have a negative environmental impact and possesses good thermodynamic properties. At the same time it is the most common refrigerant used in global large-scale refrigeration. On the other hand, ammonia is toxic and flammable. Having a precise understanding and effective control of ammonia is therefore the key to ensuring safety of a system.

One potential solution is to introduce automatic controls to enhance safety and reduce operation costs. In addition, using NH₃/CO₂ cascade systems is a mature solution to reduce ammonia charge and to enhance safety. The overall safety of refrigeration systems depends on the system's design, installation, maintenance and integrated safety measures. All procedures have to be handled properly to ensure 100% safety.

Lin Rujie, Snowman:

Snowman has always placed significance on the safe operation and maintenance of its natural refrigerant-based technology. We ensure quality and safety of products with a strict selection of material to meet not only the standards in China but also in other regions such as the EU and the United States. We have a comprehensive design and experimenting platform to consider how to control refrigerant charge to a minimum, SRM compressor developed cylinder explosion-proof technology and safe control system. Using the SRM ammonia semi-closed screw system, we were able to eradicate the risk for leaks from the seal. We also introduced advanced operating control technology with safety protection and an alarm function with a high level of self-modulated functions to avoid improper operation by operators. Finally, we organise training for end users' control and operating employees in operating and maintenance to increase awareness of the safety requirements.



Danfoss' award-winning valve station applied in a landmark CO₂ refrigeration project

INTRODUCTION

Danfoss' award-winning valve station for industrial refrigeration, called the ICF Flexline™, recently achieved a major milestone in China. The whole Flexline™ family of valves were applied in a landmark CO₂ refrigeration project at Dalian Zhangzi Island Fishery Group's scallop and sea cucumber processing centre. The Zhangzi Island is located to the north of the Yellow Sea, 56 nautical miles from the continent and as such, free from pollution. The natural environment of the island is well suited for aquaculture, which when combined with bottom-breeding technology yields high-quality seafood. Zhangzi Island's products are widely recognised as organic, green and pollution-free. Every year, Dalian Zhangzi Island distributes approximately 100 million seeds into the sea. At the bottom of the cultivation area there are so many marine creatures that it is often referred to as a "seabed bank". Three main products, Yezo scallops, trepan and abalone, all grow very well in this type of environment.

Overlooking the Zhangzi Island is a large silver building that many believe resembles a large ship. This building is the newly constructed seafood processing centre of Dalian Zhangzi Island group which combines seafood processing and cold storage. After comprehensively considering safety, the environment, and efficiency, the Zhangzi Island group decided to use CO₂ as the refrigerant for this project. Danfoss was subsequently selected as the valve supplier due to its leading CO₂ technology, vast experience with CO₂ and high quality products.

ABOUT THE SYSTEM

For this project, one major objective was to protect the environment since Zhangzi Island is located in the Changshan Islands in southern China, which are pollution-free. For the sake of environmental protection, the environmentally friendly refrigerants ammonia (R717) and CO₂ (R744) were chosen for this project.

Safety and energy savings were also major priorities for this project. With only 14.36 km² of land, the Zhangzi Island is highly concentrated and populated and safety of the local population is always a primary concern. In the newly developed seafood processing centre, the freezing plant utilises a NH₃/CO₂ cascade system for refrigeration, which lowers the NH₃ charge amount by over 90% and limits the NH₃ refrigerant inside of the refrigeration control room, fully satisfying the safety requirements of Zhangzi Island group. The cold storage plant utilises a CO₂ brine system and uses the abundant sea water as the cooling medium for the high-level ammonia refrigeration. The setting up of the condenser heat recovery appliance prior to the cooling process, realises a good balance between safety and environmental protection.

Danfoss

www.danfoss.com



Xiao Lun

xiaolun@danfoss.com

ABOUT THE COMPANY

The Danfoss group, one of Denmark's largest companies, operates in the HVAC&R and motion controls sector. Danfoss' refrigeration and air conditioning division is specialised in automatic controls, compressors and electronic sensors.



The reliability of the refrigeration system is an important element of the Zhangzi Island project, since the island is located far from the mainland and transportation is limited. Seafood processing depends heavily on reliable refrigeration systems and this is the main reason why Danfoss CO₂ solutions and components were used for the Zhangzi Island project. With leading TDR technology, Danfoss AKS 4100U series radar liquid level sensor was adopted for liquid level controlling of the NH₃/CO₂ cascade system, working together with the ICM series motor control valve for precise control of the refrigeration liquid level control. The feeding line of the freezing room uses the Danfoss premier product ICF series valve station, which compressed the installation area by 2/3 and reduced the welding time by 80%. The newly launched SVL Flexline™ series of refrigeration line components were also widely used.

Danfoss Industrial Refrigeration Flexline™ platform:

Flexline™ – a modular solution

Line Component - SVL

- » Using just two basic valve housings – a straightaway and an angleway – the platform offers 5 different functions
- » The backbone of the platform is the common housing, which is available as angleway or straightaway. All five function modules: stop, regulating, stop/check, check and filter fit the same housing
- » They all have the same high specification making selection, system design and mounting is simple and trouble-free

Valve Station – ICF:

- » Only two welding ensures the safety and fast installation with an improved efficiency
- » Innovative modular design can have the function modules assembled in the single housing

Control Valve – ICS:

- » Direct welding form is used without flange, reducing the leakage risk by up to 80%
- » The special V-port design in the ICS cone ensures optimum regulation characteristic to pilot operated main valves at partial load
- » The plug-in module adopts QPQ technology to realise excellent environmental adaptation

RESULT

Ammonia is an environmental-friendly refrigerant with excellent heat exchange efficiency. It has been successfully and widely applied in large-scale refrigeration systems all over the world. However, coming from the increasing focus on safety issues, effectively reducing the charge capacity of ammonia in the refrigeration system has become a clear trend in ammonia systems, of which the NH₃/CO₂ cascade system of Zhangzi Island has its proven advantages and is becoming popular.

What other solutions can be applied? CO₂ secondary refrigerant system, air cooler evaporators are also recommended solutions to fit to different applications. For each kind of refrigeration system including an ammonia-based one, the real safety also largely depends on the operation-reliable components, installation and maintenance. Only the success of each part makes 100% safety possible.

SUMMARY

For large-scale industrial refrigeration region of China, the Zhangzi Island's new processing plant is the first to combine both CO₂ cascade & brine systems. This is one reason why it is now considered a benchmark project in the green journey for Chinese industrial refrigeration. For the fishing and seafood processing industry, refrigeration is a key requirement for practically the entire process. Accurate and stable low temperature control is crucial in pre-processing, pre-cooling, quick freezing, post-processing and refrigeration. With vast experience in this field, Danfoss provides many leading marine companies across the globe with both components and technical support. Danfoss is rapidly becoming the leading refrigeration supplier to the fishery industry due to our reliable, efficient and environmental-friendly refrigeration solutions.

ENGINEERING
TOMORROW



Commercial refrigeration

Introduction

The market for the use of CO₂ as a refrigerant in commercial refrigeration in China is one that continues to grow in potential. Although CO₂ as a refrigerant is still in its developing stage in China, current users are already aware of the energy saving potential of CO₂ systems. The introduction of natural refrigerants in China is driven especially by global retailers that have implemented the technology in their stores in Europe and other regions. In line with their commitments to reduce emissions of their operations globally and based on their positive experience with the performance, cost effectiveness, and safety of natural refrigerant-based systems, these retailers are bringing the technology to China.

In the GUIDE survey, the industry responded with confidence that the use of natural refrigerants, in particular CO₂, in commercial refrigeration will grow significantly in the next five years.

Nevertheless, challenges remain in the Chinese market for the mass-adoption of CO₂ in commercial refrigeration, including the training of personnel, supply of components, and the initial cost barrier. In addition to this, and as can be seen from the experience of other regions, such as Europe and Japan, government policy and incentives can play crucial roles in accelerating market development and adoption of CO₂ technology. Thus, within the Chinese industry, there are expectations for increased policy and incentive schemes from the Chinese government for the technology to fully penetrate the market.

80% of components for CO₂ refrigeration systems and parts are now available within China.

China is the fastest growing world market for commercial refrigeration equipment.

CO₂-based supermarkets

MARKET DRIVEN BY INTERNATIONAL FOOD RETAIL BRANDS

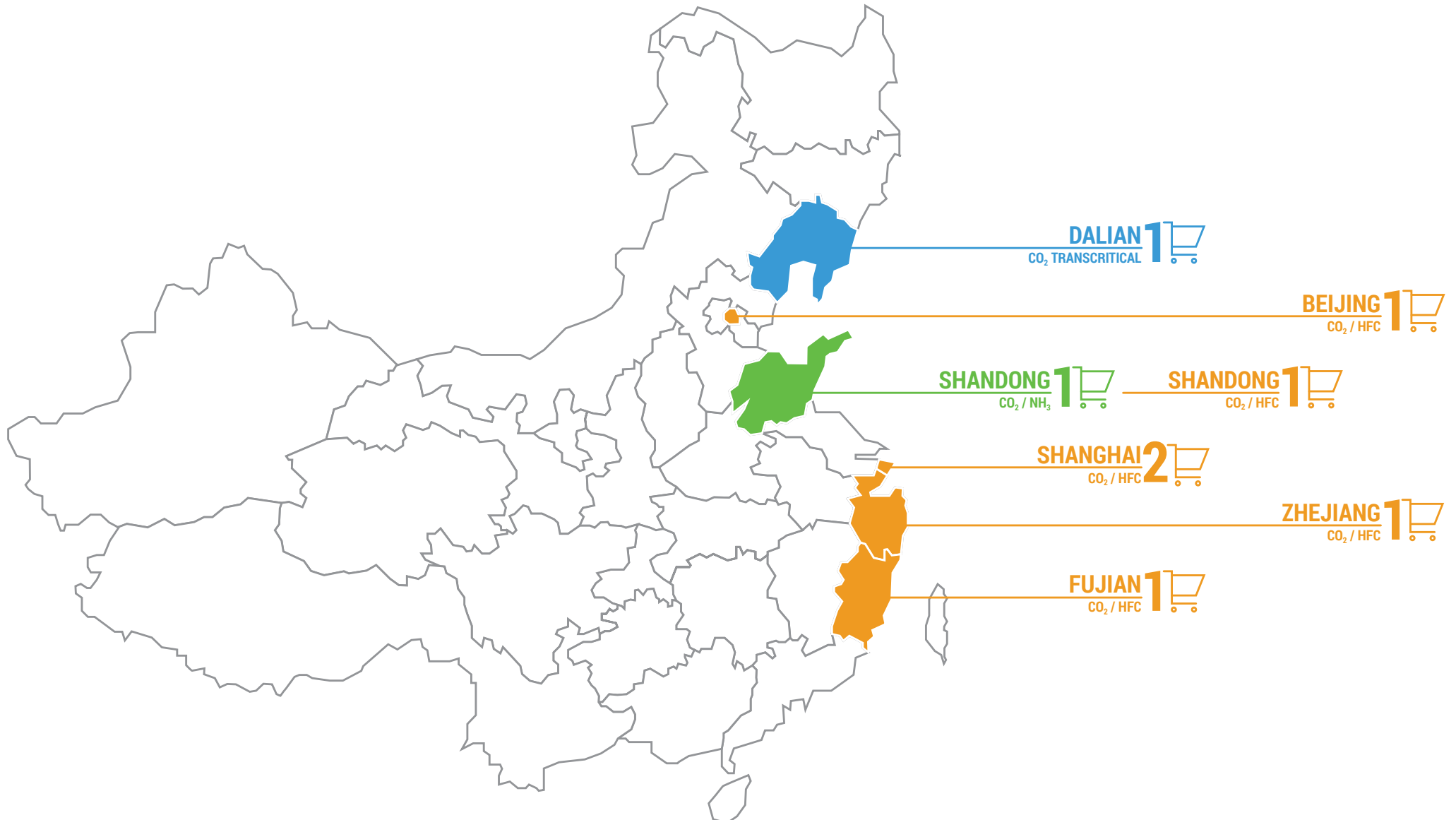

Untapped potential for CO₂ in China's supermarkets

Rapid economic development has made China the fastest growing market for commercial refrigeration. Between 2001 and 2011, China was by far the fastest growing world market for commercial refrigeration equipment, possessing growth in the double-digits during this ten-year period. However, as China's economic growth has slowed, the rate of demand for commercial refrigeration products is decelerating; nevertheless it still remains the fastest in the world.

According to shecco's research among system manufacturers, there are currently 8 supermarkets using CO₂ as a refrigerant. This confirms the notion that the market potential for CO₂ in commercial refrigeration is largely untapped in China. The transformation to modern refrigeration technology in China has only occurred very recently, with the first supermarket using CO₂ as a refrigerant in 2011. The market potential is still building but is expected to gain continued growth in the coming years as a result of regulatory pressure and increased demand for climate friendly technologies.

Although natural refrigerant-based technology in commercial refrigeration is still new in the

Chinese market, there is already a good mix of technology represented. Besides CO₂/HFC stores, there is a CO₂ transcritical supermarket as well as a CO₂/ammonia installation among the 8 CO₂-based stores currently in place. The CO₂ transcritical system is currently being trialled in Dalian city in Liaoning province. Once the testing phase is completed, it is expected that more CO₂ transcritical stores will appear in China.

The use of CO₂/NH₃ systems has also been quickly developing in industrial refrigeration in China, and the solution is recognised as ideal for commercial applications. Currently there is one store in Shandong province utilising a CO₂/ammonia system. Indicative of the future growth of CO₂-based technology, Metro China, as one of the most active retailers in sustainable refrigeration today, plans to use CO₂ hybrid stores as their standard, starting from 2016. In 2015, the retailer plans to open one CO₂ new store and remodel five other stores using CO₂ hybrid technology. In 2016, Metro has plans for opening another 5 new stores together with six remodels. Moreover, Metro is aiming to complete its first CO₂ transcritical supermarket in China in 2016-2017.

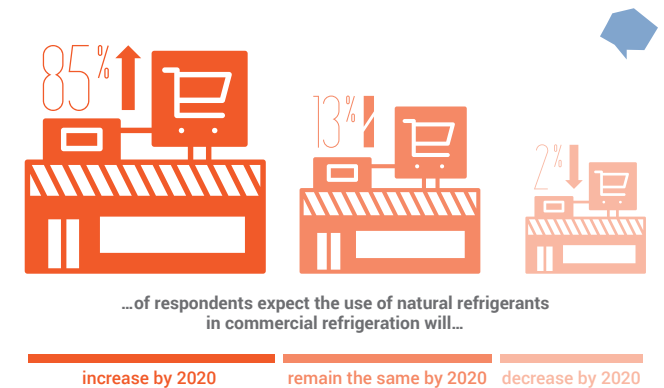

Number of respondents: 536

Natural refrigerants have a central role in commercial refrigeration in store

When survey respondents were asked to predict the market for natural refrigerant technologies in commercial refrigeration applications by 2020, 83.9% of respondents predicted that it will increase either significantly or slightly; 13.5% thought that the market will remain the same as today, and 2.6% believed that it will decrease either slightly or significantly.

There was a unanimous verdict on the future of natural refrigerants within commercial refrigeration, showing that foreign companies' efforts to introduce the technology have been accepted by the Chinese industry. The increase in demand will also lead to a drop in initial cost, inciting further demand in a virtuous circle.

International food retailers driving introduction of CO₂

Driven by the global commitments to reduce the carbon footprint of their stores, food retailers with international operations have been the first to introduce natural refrigerant-based technology to Chinese supermarkets. So far, two retail chains, Tesco and metro, have introduced CO₂ refrigeration systems in their stores in China. Their decisions were strongly influenced by positive experiences with such technology in other markets, especially in Europe. Both retailers

see the benefits of applying CO₂-based technology, such as energy savings, the short return on investment and CO₂'s low environmental impact. Other retailers with operations in markets where CO₂ has been widely adopted are considering opening a natural refrigerant-based store in China. With the growing focus on environmental sustainability, retailers will be taking steps toward becoming socially and environmentally responsible corporations.

CO₂ components becoming increasingly available

The limited number of local component suppliers of CO₂ technology represented a major obstacle for the introduction of the technology, as importing of components had negative implications for the cost. The first CO₂ store was built with substantial support from partners in Australia, who, besides manufacturing the refrigeration rack, also provided support to the local supplier with design, installation and commissioning of the system. Within the last four years, availability of components in China has noticeably improved. 80% of components for CO₂ refrigeration systems and parts to service the technology are now available within China. Compressors and related parts still need to be mostly imported, but availability

within China is on the rise, increasing market competitiveness and giving system suppliers greater choice. The majority of component suppliers are still foreign-owned enterprises or joint venture companies.

With the support of the government, a greater range of industry leaders have come to recognise the potential benefits of CO₂ technology and the positive impact it can bring to the supermarket and other industries. The market demand for CO₂ technology will increase exponentially, which will fuel extensive investment into the area, thus resolving the current shortage of equipment and supply in the industry.

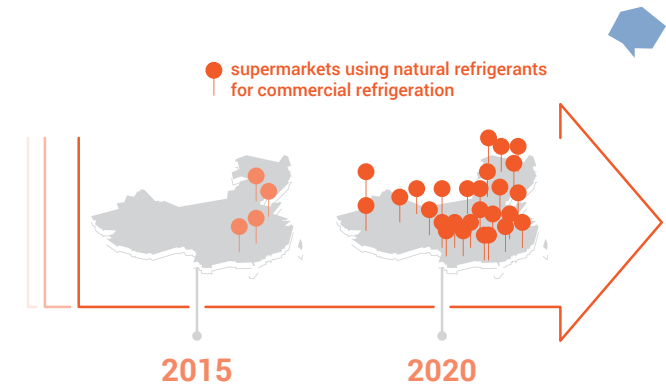

CO₂ is likely candidate to take up the increase in demand in commercial applications

In the survey, CO₂ in commercial refrigeration is ranked fourth out of 11 applications in regards to the current business and policy climate, receiving an average of 3.4 out of 5 from the respondents. When asked about the potential by 2020, the respondents confirmed that CO₂ in commercial refrigerant will continue to grow, again ranking it fourth of 11 applications, with an improved average rating of 3.7 out of 5, compared to the 3.4 given for today's business and policy climate.

The use of CO₂ in commercial refrigeration is seen to have one of the best current business and policy climates for natural refrigerants it is also one of the applications with the highest growth potential in China in 2020. Therefore, it is expected that R744 will fuel the forthcoming surge in demand for natural refrigerants in commercial refrigeration.

Initial cost and lack of trained personnel impede faster CO₂ rollout

Higher capital cost of CO₂-based technology compared to traditional HCFC or HFC-based systems is one of the key obstacles in accelerating the adoption of HFC-free technology in China. While price gap is narrowing with the increased availability of components and equipment in China, as is the case with any new technology that has not yet reached higher production capacities, the investment cost currently remains higher. This is due to lack of servicing infrastructure, as well as availability of CO₂-based equipment and parts. Without subsidies or support schemes from the government, there is not enough incentive for end users to invest in the technology, which would,

in turn, enhance its competitiveness within the Chinese market. The competitiveness of the technology within the Chinese market.

The lack of staff educated to service and maintain CO₂ based technology in China is another important barrier. Increased focus on CO₂ training for the CO₂ systems is an important step that end users and system manufacturers must introduce to complement the technology. With end users' awareness of environmental benefits and the energy efficiency of CO₂ systems in China, there is a growing demand for increasing investment and training of staff to meet the CO₂ system requirement.

CO₂ provides 25-40% energy saving benefit to China's supermarkets

The energy efficiency benefit of a CO₂ refrigeration system is already receiving acknowledgment in existing stores.

In the first CO₂/HFC cascade store opened by Tesco in Shanghai in 2011, the store consumes 25% less energy compared to a conventional HCFC-based system in a standard store design. In Tesco's second CO₂ cascade store that opened in Beijing in 2012, the system achieved 35% energy savings compared to conventional stores. And due to the success of the previous systems, Tesco opened a third CO₂ store in Xiamen, which

achieved a 25% reduction in annual energy costs, even in China's warmer southern climate.

Similar energy savings have been reported by Metro that opened its first CO₂ cascade store in 2014. The store is located in Shandong Province where there is a lower ambient temperature. From the data so far, the new system saves 30-40% of energy compared to a conventional system. Metro is very satisfied with the result and is looking to open up a second CO₂ cascade store in 2015.

Besides the energy efficiency benefits of CO₂



CO₂ commercial refrigeration booming in markets abroad

In markets abroad, the number of CO₂ stores is growing fast in regions such as Europe, Japan and North America. In Europe, CO₂ transcritical stores grew by 117%, from 1,330 stores in 2011 to 2,885 in 2013. Industry sources now predict that starting from 2016, more than 6,000 CO₂ transcritical racks will be added to the European market each year. Following that rationale, in 2020, there will be more than 32,000 CO₂ transcritical systems. By 2025, and within just five years, the number could double to more than 64,000. As of February 2015, there are more than 118 transcritical CO₂ stores and an estimated 200 CO₂/HFC stores in operation in North America.

In Japan, the market is led by end users such as Lawson and AEON. By the end of February 2015, Lawson, aiming to become the world's number one natural refrigerant retailer, has 570 CO₂ transcritical stores. In addition to this, AEON is planning to exclusively use CO₂ as a refrigerant in new stores from 2015 and gradually replace systems in their existing 3,500 stores with CO₂-based systems. According to data collected from end users and system manufacturers, the number of CO₂ transcritical stores has increased to 763 by March 2015, from 190 in March 2014, which is a 400% increase in just one year.

systems, lower maintenance costs are also seen as one of the drivers for adoption of the technology. Moreover, the end users see the HFC-free

technology as a future proof solution that will not be affected by potential restrictions on the use of HFCs and HCFCs.

Active government support could speed up CO₂ introduction

The HCFC phase out schedule in China, starting from 2015, encourages the industry to invest in environmentally friendly technologies, such as natural refrigerants. In addition to this, the government puts an increasing emphasis on energy efficiency in China's 12th Five Year Plan. Nevertheless, clear support for natural refrigerants in commercial refrigeration that would incentivise end users to purchase such technology has not yet been implemented. More active government support in the form of subsidies or incentive programmes could play an important role in accelerating the availability of CO₂ compressors and other components as well as raising awareness of technology and increasing training.

Outside China, other regions around the world have set a precedent for supporting the adoption of natural refrigerant solutions in the commercial refrigeration sector. In 2015, the EU F-Gas Regulation came into force, specifying that by 2030, the supply of fluorinated gases (manufactured in as well as imported to the EU) shall be reduced by 79% compared to the average of 2009-2012 levels. The Regulation also sets bans on the use

of HFCs, including in commercial refrigeration sector. Similarly, in Japan, the revised F-Gas Law that aims to phase down HFCs and to promote alternative technologies entered into force in 2015. In addition to this, the government has provided financial subsidies to end users to install natural refrigerant technology in industrial and commercial refrigeration facilities. In North America, the U.S. Environmental Protection Agency (EPA) has approved the use of CO₂ as a refrigerant for different applications, including food retail refrigeration, under the Significant New Alternatives Policy (SNAP) Programme.

The variety of policy actions in these regions have resulted in increased interest in CO₂ technology, which has driven availability. Subsidies and incentive programmes are essential to supporting the adoption of CO₂ technology. Government programmes to increase the awareness of environmental protection and energy efficiency of the general public would become important incentives for end users in China to commit to natural refrigerant-based solutions.

Exclusive interviews - Commercial refrigeration



WHAT ENERGY AND COST SAVINGS CAN BE ACHIEVED BY USING CO₂ AS OPPOSED TO HFCS OR HCFCs IN COMMERCIAL REFRIGERATION?

**Tommy Angback,
Alfa Laval:**

A modern cascade system will be more efficient than older systems. Moreover, heat recovery for transcritical systems will enable big energy savings.

**Massimo Casini,
Dorin:**

The latest developments in refrigeration systems (like parallel compression and ejectors) are providing very interesting results in terms of annual COP and running costs. However, it is quite difficult to give fixed figures of energy / costs advantages due to the impact of design concepts and ambient temperatures.

WHAT STEPS ARE YOU PLANNING TO TAKE TO ADDRESS THE LACK OF TRAINED PERSONNEL AND ENSURE SAFE OPERATION OF NATURAL REFRIGERANT-BASED SYSTEMS?

**Holger Guss,
Metro:**

Indeed this is a very important point to consider as the reliable and error-free operation of the refrigeration system is one of the key factors to guarantee our business. Therefore we are planning to start with more advanced plant concepts in first-tier cities in China. We assume that the skills of service companies will improve and grow as market penetration does, but this process might take some time - like in other countries before. However, all in all we are confident that we have the right and competent partners in China, who are committed and devoted to joining us on our path to implementing more environmentally friendly and sustainable technical concepts.

HOW DO YOU ASSESS THE PROGRESS WITH CO₂ TECHNOLOGY IN DIFFERENT APPLICATIONS IN CHINA UNTIL TODAY AND WHAT CAN WE EXPECT BY 2020?

**Zhong Zhifeng,
FECO:**

All new technologies - including CO₂ - need time to be accepted by the market, so it will take some time to see the full results of CO₂'s integration into the market. In this process, FECO/MEP will try its best to promote these environmentally friendly and energy efficient technologies. In terms of expectations, I believe that in 2020, more refrigeration and air conditioning systems will use natural refrigerants and good progress will be made not only in China but across the world.

室内安装 Indoor Installation



室外安装 Outdoor Installation



中温制冷能力 MT capacity 35 - 185 kW / CO₂
低温制冷能力 LT capacity 3 - 100 kW / CO₂



COOLtec Range Mini

MiniCOOL₂

特点/选项 Features / Options

- 中温 / 低温多头机组合机组，中温CO₂跨 / 亚临界制冷以及低温CO₂亚临界制冷
Combined MT< multi-compressors racks with CO₂ transcritical / subcritical medium temperature - and subcritical low temperature refrigeration
- 安装于室内或室外，可选室外安装机罩
Indoor or outdoor installation with optional weather protection housing
- 专为CO₂跨 / 亚临界制冷开发的开利控制器（控制机组及气冷器）
Mounted Control panel with Carrier controller, especially developed for CO₂ transcritical and subcritical operation (rack & gas cooler)
- 中温压缩机2至3台，可选变频控制
2 to 3 MT compressors, VFD option
- 低温增压压缩机1至2台，可选变频控制
1 to 2 LT compressors booster, VFD option
- 前方及侧面维护，节省机房空间
Ability to service from front and side only saves machinery room space





FROM AN END USER PERSPECTIVE, WHAT ARE THE REMAINING CHALLENGES SLOWING DOWN OR IMPEDING THE ADOPTION OF NATURAL REFRIGERANTS IN CHINA?

Holger Guss, Metro:

The lack of well-educated and experienced staff and suppliers is an important point to consider. Due to the low market penetration in China, the additional costs for the implementation of natural refrigerant systems are more substantial than in other countries where natural refrigerants are more established. Moreover, we are facing obstacles with the implementation of energy efficient and environmentally friendly R290 plug-in cabinets in our stores in China.

HOW DO YOU ASSESS THE SITUATION REGARDING THE AVAILABILITY OF COMPONENTS FOR CO₂ REFRIGERATION SYSTEMS IN CHINA?

Jefferson Li, Haier-Carrier:

Haier-Carrier has already implemented several CO₂ projects in China and is in the process of installing other new projects using CO₂ solutions. Currently all the necessary components are avail-

able within the Chinese market, however many additional components still have to be imported. This creates the issue of increased lead-time and cost, but we believe that with the expected increase in demand for CO₂ units, this will speed up the components localisation by suppliers.

WHAT ARE THE NEW NATURAL REFRIGERANT SOLUTIONS YOU ARE BRINGING TO THE CHINESE MARKET?

An Jingai, Danfoss:

For the food retail market Danfoss offers a complete range of CO₂ system solutions including the ADAP-KOOL® control and monitoring systems, regulation and ejection valves, sensors (temperature, pressure, gas detectors), filter-driers and line components. To date, Danfoss components have been used in hundreds of subcritical CO₂ systems and more than 1,000 transcritical systems.

WHAT IS THE TOTAL COST OF OWNERSHIP OF A STORE USING CO₂ REFRIGERANT IN CHINA, AND WHAT ARE THE REASONS FOR INVESTMENT IN SUCH A TECHNOLOGY DESPITE HIGHER UPFRONT COSTS?

Jefferson Li, Haier-Carrier:

The lifecycle cost of a CO₂ system is lower than a conventional R404A system, but of course the exact level of savings depends on the store format. So while the initial cost will be slightly

higher, a CO₂ system can provide up to 10% in energy savings and of course, has close to zero environment impact.

The clear path to a smaller carbon footprint.

Emerson offers a future-proof solution through CO₂ technologies

Commercial refrigeration users throughout the world are moving towards phasing out harmful refrigerants and are looking for alternatives. Emerson CO₂ technology leads the trend to efficiency. This refrigerant's non-ozone depleting, non-flammable and near-zero global warming potential properties create an ideal solution towards reducing your environmental footprint.

The efficiency, reliability and liquid-handling advantage of Copeland Scrolls, coupled with Emerson Climate Technologies controls, components and transcritical compression architecture makes it ideal for exploiting the positive characteristics of CO₂ refrigeration systems.

Learn more about the future of refrigerants through the podcast audio below or read the white papers under CO₂ Solutions at EmersonClimate.com



*Scan to listen to
the podcast now*

Emerson Climate Technologies is a trademark of Emerson Electric Co. © 2014. All Rights Reserved



EMERSON. CONSIDER IT SOLVED.™



Alfa Laval's CO₂ refrigeration system at the S-Market building in Helsinki, Finland

INTRODUCTION

At the new S-Market building in Helsinki, Finland, cooling and terminal rooms are full of evaporators labeled and manufactured by Alfa Laval. Alfa Laval was able to help S-Market become one of the few supermarkets in Finland to use CO₂ refrigerant.

"In this very interesting project our customer, the S-Group, gave us a few prerequisites for the type of cooling equipment they wanted. The most crucial requirement was carbon dioxide, which had to be used as the refrigerant," says Taisto Tolonen, project manager at Norpe Finland, the company that installed the supermarket's cooling system. "You know, the most commonly used refrigerant in Finnish supermarkets is still artificial. The challenge is that it does not meet the upcoming F-gas legislation, which will be enforced in a few years."

Currently there are no more than 50 supermarkets in Finland where carbon dioxide is used as a refrigerant. According to Tolonen, Norpe and Alfa Laval have been cooperating since the 1970s. This latest project started with a visit to Alfa Laval Italy in December 2011, where the carbon dioxide evaporators are manufactured. "Although carbon dioxide is nature's own gas, it does not act like traditional, more commonly used refrigerants," says Hannu Viikilä, Alfa Laval Nordic and project owner.

ABOUT THE SYSTEM

S-Market's cooling system includes an Optigo CC air heat exchanger in their freezer, and Optigo CD coolers in their fish, chicken, ready-food, fruit and vegetable cold storage rooms. Both models are part of Alfa Laval's Optigo range of energy efficient and environmentally friendly air heat exchangers.

There are currently three models available in the range, which have been optimized for CO₂ and are easy to install, making them ideal for small to medium commercial applications, such as supermarkets, restaurants and chilled food storage.

Optigo CD

For cooling and freezing rooms where high activity demands increased airflow, the Optigo CD provides double airflow, but low air velocity and noise levels. As with the other products in the Alfa Laval Optigo product line, the CD model is easy to install and clean and follows HACCP guidelines for food safety.

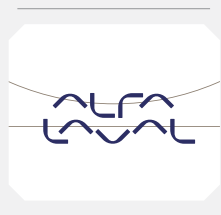

Alfa Laval

www.alfalaval.com

Alireza Rasti

ali.rasti@alfalaval.com

ABOUT THE COMPANY

Alfa Laval is a leading global provider of specialized products and engineered solutions. The company's equipment, systems and services are dedicated to helping customers to optimize the performance of their processes. Condensers, evaporators and gas coolers from Alfa Laval make transcritical CO₂ and cascading systems responsible, efficient, reliable and safe. Alfa Laval has the products and expertise, from air coolers to complete transcritical CO₂ solutions with heat recovery. Alfa Laval's worldwide organization works closely with customers in almost 100 countries to help them stay ahead.



S-Market's cooling system consists of one Optigo CD cooler in the fish cold room (0-2°C or 32-35.6°F), chicken cold room (0-2°C or 32-35.6°F), ready-food cold room (3-5°C or 37.4-41°F), fruit and vegetable cold room (6-8°C or 42.8-46.4°F), as well as three coolers in the terminal area (2-4°C or 35.6-39.2°F).

Optigo CC

Optigo CC is the perfect single flux choice for larger-volume applications.

It has a clever design with a new highly efficient coil (for reduced refrigerant content) and the same footprint as the previous series. This makes it easy to install and connect, while high energy efficiency gives low lifecycle costs. An Optigo CC has been installed in S-Market's freezing room (-20 to -18°C or -4 to -0.4°F).

RESULTS

"In order to guarantee the highest possible quality for our products, we tested certain units and then created design programs with which to secure exact capacities," says Hannu Viikilä. Carbon dioxide has good heat exchanging ability, but its drawback has always been its 'high working pressures'. However, Viikilä points to the isolated bunker that Alfa Laval has built at its manufacturing site in Alonte, Italy, where long gas coolers can be pressure tested with 172 bar.

"I can proudly say that our clear strength is the ability to combine theory and praxis," adds Hannu Viikilä. "We are able to show how carbon dioxide reacts at different pressures and our global development team was strongly committed to the correct CO₂ calculation methods."

Norpe also knows that Alfa Laval has a long reference list concerning challenging refrigeration environments, including supermarkets. "us, as an installer and contractor, it was of great importance to have a reliable and experienced component supplier," states Lasse Silvan, project engineer from Norpe. "We also appreciate the quick service in our native language, as well a high level of technical know-how on the part of Alfa Laval's contact persons."

According to Silvan, the project did not meet any significant challenges. Supplies came as agreed, and there were no surprises during the pressure and leak tests, which Norpe carried out after installation in November 2012. "

SUMMARY

Lasse Silvan, Project Engineer, Norpe Finland:

“Alfa Laval's high commitment to new environmentally friendly cooling solutions is admirable. After many years of close co-operation I can say that they are honestly interested in customers' needs and are ready to fulfill those to the smallest detail.”

Hannu Viikilä, Segment Manager, Alfa Laval Nordic:

“I appreciate Norpe's openness to the new and sustainable solutions we can offer. When operating with such a challenging refrigerant like carbon dioxide, it is rewarding that our partner also wants to see our R&D environment with all of its frills.”





Haier-Carrier pump CO₂ system installed at Ningbo store

INTRODUCTION

In recent decades, with the increasing awareness of the negative impact of HCFCs on the ozone layer and the role of HFCs in increasing greenhouse gas emissions, the environmentally friendly natural refrigerant CO₂ has continued its emergence. CO₂ is being used in more and more applications and is now a well-adopted refrigerant in commercial refrigeration. Haier-Carrier's pump CO₂ system is a technology principally designed to use CO₂ in a bid to reduce the selection of HCFCs and HFCs as refrigerants.

NINGBO CO₂ STORE

Ningbo store was opened in January 2013 with Haier-Carrier pump CO₂ system. The system has a cooling capacity for MT (medium temperature) of 341.8kW and for LT (low temperature) of 90.4kW. The mechanical room area is up to 90m² space.

Medium temperature equipment:

- » 27 multideck and semi-multideck systems with capacities of 87.1 kW
- » 15 service counters with capacities of 14.4 kW
- » 5 cold rooms with capacities of 26.7 kW
- » 4 preparation rooms with capacities of 28.3 kW

Low temperature equipment:

- » 5 glass door freezers with capacities of 6.6 kW
- » 17 island freezers with capacities of 15.54 kW
- » 3 cold rooms with capacities of 17.06 kW
- » 2 ice makers with capacities of 21.8 kW



Haier-Carrier

www.haier-carrier.com

Linda Li

Linda.li@haiercarrier.com

ABOUT THE COMPANY

Qingdao Haier-Carrier Refrigeration Equipment Co., Ltd. is a joint venture by Haier and Carrier, which began in 2001. In the last ten years the venture has developed a global-scale production factory and is ISO9001 and UTC ACE certified. Its products include supermarket display units (more than 1000 models), compressor units (scroll, screw, and heat exchangers (air cooled condenser and air cooler), which all provide comprehensive refrigeration solutions for clients. With the support of R&D centres in Mainz, Germany, and in Shanghai, Haier-Carrier boasts R&D labs recognised by the Chinese government.

TECHNOLOGY BACKGROUND

Traditionally, CO₂ refrigeration systems work under high pressures, and from a system safety and energy saving standpoint, supermarkets commonly adopt cascade refrigeration systems, using a secondary refrigerant to abate these concerns. In a cascade system, CO₂ provides a condensing function at a relatively low temperature in a refrigeration system used in high temperature refrigeration system, essentially solving the challenge that high-pressure CO₂ faces in high ambient temperatures. In conventional cascade refrigeration systems used in supermarkets, medium temperature refrigeration systems often use HFCs as the secondary refrigerant, which still have a high environmental effect.

KEY FEATURE OF PUMP CO₂ SYSTEM

With current technology, most medium-temperature refrigeration systems use large quantities of refrigerant and CO₂ is only used in low-temperature refrigeration systems.

In a CO₂ pump system, LT refrigeration systems use CO₂ direct expansion systems and MT refrigeration systems use a pump to send CO₂ in an indirect refrigeration cycle. At the same time, it combines water-cooled condensing systems to circulate the cascade high-temperature HFC refrigerant only in the machinery room, in order to reduce the use of HFCs significantly.

In January 2013, Haier-Carrier designed the first system using this technology in a supermarket in Ningbo, China, utilising all-CO₂ equipment. The system uses a CO₂ pump system in medium temperatures. In low temperature refrigeration and the ice-making application, the system utilises the CO₂ direct expansion system. The system has functioned without problems since operation commenced, with pressure and other factors all meeting design requirements. The supermarket using this system has so far attracted many customers and cold storage clients as visitors to learn about the system's operation.

RESULTS

As mentioned, units utilising natural refrigerant CO₂ do not contribute to ozone depletion or environmental pollution. In addition, CO₂ has excellent heat exchange efficiency, which can reduce the refrigerant charge by almost 50%. Systems using CO₂ can also be compact, saving on machinery room space for clients. The energy efficiency of this system is 10% higher compared with a conventional system using other refrigerants and also saves operation cost for clients. As a leader in the commercial refrigeration industry, Haier-Carrier always endeavours to follow the green refrigeration path while providing products with higher energy efficiency for its clients.



Haier 

Carel's solutions for transcritical CO₂ system installed in Carrefour in Italy

INTRODUCTION

Thanks to the partnership among Carel, Carrefour and Enex, a new supermarket in Aosta has become fully green. Installed in September 2013, the refrigeration system now uses carbon dioxide as the sole refrigerant for cold food storage.

Carrefour, committed to replacing its HFC systems, first with hybrid CO₂/ R134a solutions, and then with refrigeration systems that only use CO₂, inaugurates this new hypermarket that stands out for its size and the specific configuration with three suction lines - MT1, MT2 and LT.

ABOUT THE SYSTEM

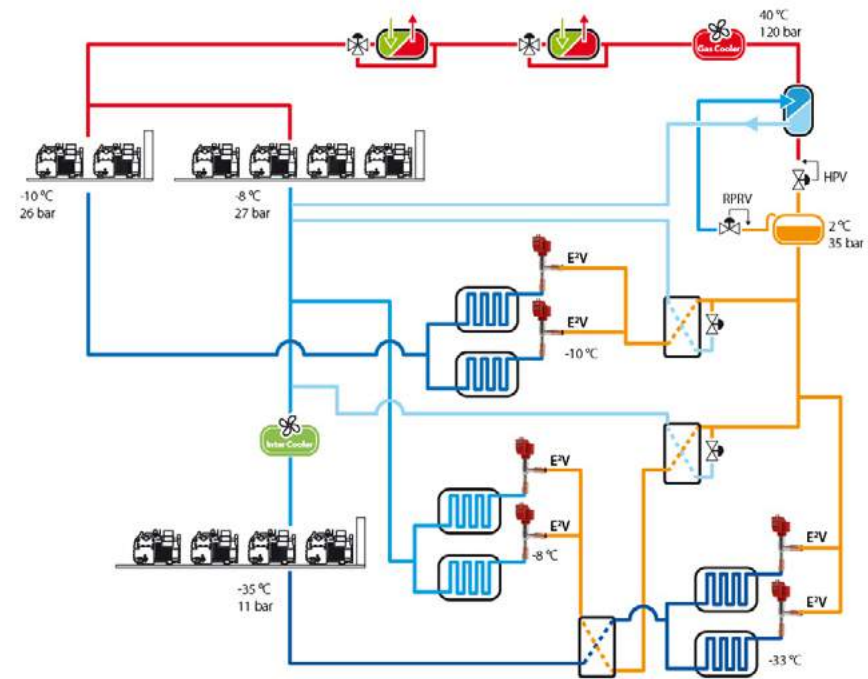

CAREL

Carel
<http://www.carel.com>

Hanyi Zou
hanyi.zou@carel.com

ABOUT THE COMPANY

CAREL has been working in the field of refrigeration, air conditioning and humidity control since 1973. CAREL solutions are specifically tailored for the management of chillers, compressor packs, showcases, multiplexed cabinets, cold storage rooms, seasoning rooms, retarders, air handling units, roof-top units and air-conditioning units. These solutions are used world-wide, both by the most well-known OEMs and by the most demanding installers in the HVAC&R market.

The compressor rack is a transcritical CO₂ booster system. The pRack controller manages three suction lines, comprised of four compressors (LT), four compressors (MT1) and four compressors (MT2).

Specifically, the low temperature (-35°C) compressor discharge is first cooled by an intercooler featuring two ON/OFF fans and is then delivered to the first medium temperature suction line (-8°C). Independently from the booster system, a second medium temperature suction line provides a third level of evaporation (-10°C). The compressor discharge on the two medium temperature lines flows into the condenser line, where a system of three heat exchangers provides for heat recovery in two stages, firstly for domestic hot water and secondly as for room heating. Both are managed directly by the Carel pRack board and the Carel IR33 universal controllers. The third heat exchanger is placed in series with the first two, and can be used manually for system safety.

pRack provides temperature control of the gas cooler, featuring EC fans, based directly on the heat exchanger outlet temperature, with the possibility to adjust the control set point based on variation in outside temperature (floating condensing pressure function). Between the gas cooler and the HPV valve is a subcooler, which exploits the colder fluid from the flash valve to further cool the CO₂ at the high pressure valve inlet.

The HP valve is controlled by pressure; the set point is calculated based on the saturated temperature at the gas cooler, with the aim of ensuring the optimum pressure for compressor rack COP in transcritical conditions or the ideal level of subcooling in subcritical conditions.

Liquid refrigerant is delivered from the receiver directly to the low temperature units, where it is expanded to cool the cabinets and cold rooms, while the medium temperature units receive superheated refrigerant via a series of heat exchangers controlled based on superheat using the Carel EVD DRIVER controllers. From the three temperature levels at the refrigeration units, the CO₂ is then injected into the three separate suction lines and the flash valve.

CONTROL SYSTEM

pRack pR300T

The compact CAREL solution for complete control and management of CO₂ refrigerant systems is ideal to meet the considerable market demand for the following:

- » integrated management of low and medium temperature compressors (two suction lines) and transcritical valves;
- » innovative energy saving management algorithms;
- » algorithms dedicated to the management of CO₂ systems;
- » management of heat recovery in two separate stages (domestic hot water and room heating)
- » ample possibility for integration/supervision



PlantVisor PRO

Complete and reliable solution for the management, monitoring and optimisation of refrigeration and air-conditioning systems with up to 300 units:

- » management of large and complex systems using an intuitive web interface;
- » HVAC-ECO optimisation package;
- » fast installation onsite;
- » alarm management using a powerful engine of rules, conditions and notification channels;
- » complete series of reports and documents, such as HACCP and SYSTEM REPORT.



RESULTS

Safety: Following the CO₂ refrigerant thermo-physical properties, Carel integrated a control system for an easy management and operation with the complete control logic and safety features being the same as for traditional refrigerant systems.

Performance: With the best monitoring platform and reliable design, customers are able to manage the system more intuitively and effectively.

Energy Efficiency & Environment: The Carrefour CO₂ refrigeration system achieves about 30% energy reduction due to an efficient heat exchanger with CO₂ and the specific configuration with a three suction lines design.

SUMMARY

Carel has implemented the new CO₂ refrigeration system control for both low temperature cabinets (frozen food) and fresh produce. Because the project is centred around environmental sustainability, the system relies on a completely natural refrigeration technology.

The CAREL pRack PRK300T electronic controller, by adopting innovative control algorithms to manage at the same time the compressor, heat recovery and the transcritical section, can achieve maximum efficiency and savings in energy consumption. Carel has once again proven to be a sustainable innovator, applying its technology to provide cooling using carbon dioxide, while ensuring the lowest possible energy consumption.

High
Efficiency
Solutions.

CAREL

Light commercial refrigeration

Introduction

The market for natural refrigerants in light commercial refrigeration equipment in China has been developing fast in the past few years; mainly driven by global consumer brands' commitment to natural refrigerant-based solutions. In line with the expansion of these global consumer brands' activities in China, the demands for natural refrigerants in light commercial applications will increase accordingly. Acknowledging energy efficiency and consumers' increasing awareness for environmental concerns, Chinese consumer brands are also starting to apply natural refrigerant solutions in light commercial applications.

Respondents from the Chinese industry survey predicted that the market for natural refrigerants in light commercial refrigeration would increase by 2020. In the current business and policy climate for natural refrigerants products, hydrocarbons are viewed slightly more positively than CO₂. However, in terms of market potential by 2020, CO₂ is perceived to have a slightly higher potential than hydrocarbons. Overall, both CO₂ and hydrocarbons in light commercial refrigeration are perceived positively in comparison with other applications.

At least 750,000 HFC-free light commercial refrigeration units are placed in China today.

85% of industry expects an increase in the use of natural refrigerants in light commercial refrigeration by 2020.

HCs and CO₂ in light commercial applications

MARKET DRIVEN BY GLOBAL CONSUMER BRANDS



400,000

HC stand alone cabinets

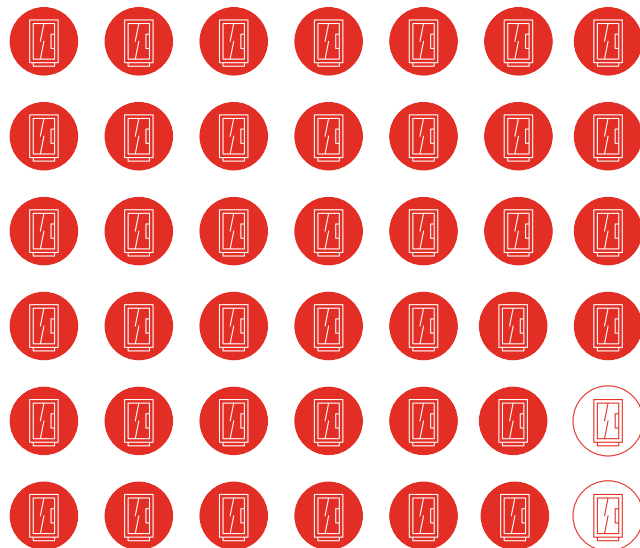

322,000

HC ice cream freezers

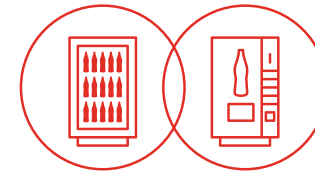
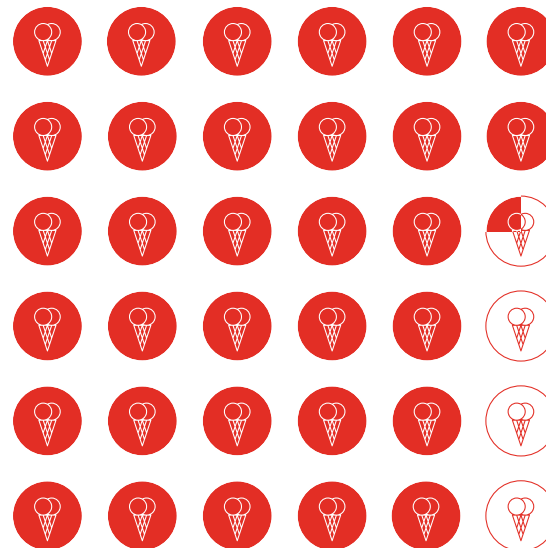

2,500

HC bottle coolers
& vending machines

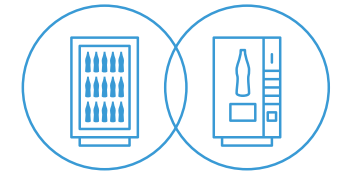

25,000

CO₂ bottle coolers
& vending machines



CO₂ and hydrocarbons already widely used in China

Rapid urbanisation and the change of lifestyle in China have generated a rapid growth of juice, ice cream and frozen food consumption. As a result, the demand for light commercial refrigeration equipment is growing accordingly. For example, stand alone cabinets alone account for annual market demand of 1.3 million units according to 2014 figures.

Natural refrigerants, particularly hydrocarbons and CO₂, are playing increasingly important roles in China's light commercial refrigeration sector. The data collected from leading equipment manufacturers and end users in 2014 indicate that

there are already at least 750,000 units of HFC-free equipment in light commercial refrigeration in China today. The existing HFC-free equipment includes stand-alone refrigerated cabinets, ice cream freezers, bottle coolers and vending machines, and uses predominantly hydrocarbons – propane and isobutane - as refrigerants. CO₂ is mostly used in bottle coolers and vending machines and accounts for 25,000 units according to the data shecco collected from the industry in 2014.

Global consumer brands – the force behind introducing natural refrigerants in China

The increase of natural refrigerants in the light commercial refrigeration sector in China has two major drivers. Foremost, there is an overall increase in demand for light commercial equipment. The key driving force, however, are the global end users who have voluntarily committed to phasing out of HFCs in new equipment and replacing them with natural refrigerants as much as possible.

Global consumer brands such as the Coca-Cola Company, Red Bull, Unilever, Nestle and PepsiCo are all members of the Consumer Goods Forum, under which they made a commitment in 2010 to eliminate HFC-based refrigeration equipment and

move globally to the use of natural refrigerants as of 2015. The Chinese market is no exception for these brands, so efforts are ongoing to eliminate the use of HFCs in the companies' new light commercial equipment used in China.

The demand from global end users is driving the local industry to pay increased attention to natural refrigerant solutions. This subsequently results in growing availability of HFC-free equipment in the Chinese market. Meanwhile, an increasing number of domestic consumer brands, such as Mengniu Dairy, have also become aware of the energy efficiency benefits of natural refrigerant-based equipment and have started

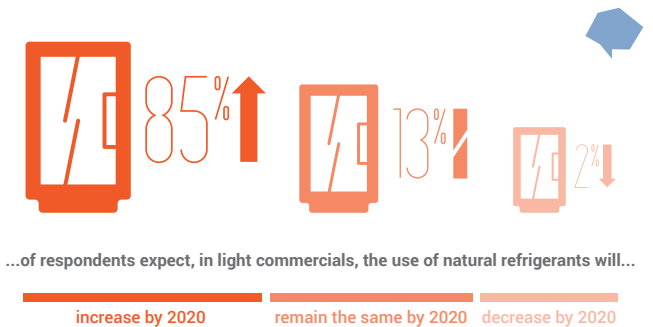

Number of respondents: 536

A refreshing future expected for natural refrigerants in light commercial refrigeration

When asked to gauge the level of adoption natural refrigerants will obtain in light commercial applications by 2020, 83% of respondents indicated they expect the usage to increase. Only 3% expected the usage of natural refrigerants to decrease in light commercial applications and 14% expect it to stay the same.

Therefore, the future for both CO₂ and hydrocarbons in light commercial refrigeration in China seems auspicious, with the large majority of the industry survey respondents predicting an increase in use by 2020 due to increased in numbers propagated by global consumer brands who are looking to minimise their environmental impact.

to demand natural refrigerant-based equipment from local suppliers. The Chinese dairy product supplier has invested in a series of R290 freezers

that reduce energy consumption by 30%, significantly cutting down the cost of operation.

Different strategies with the same target – replacing f-gases with natural refrigerants

While the aim of the major global end users is to get to the same target – moving away from HFCs and replacing them with natural refrigerants – the individual targets, steps taken and types of natural refrigerants selected vary from end user to end user, usually based on their respective global strategies.

In line with its global goal to reduce the carbon footprint of “the drink in your hand” by 25% by 2020 and to use HFC-free refrigerants in all newly-purchased equipment, the Coca Cola Company has placed more than 25,000 CO₂-based cold drinks equipment in China since 2007.

A number of global and domestic consumer brands have committed to using hydrocarbons, which have been specifically selected for their energy efficiency. PepsiCo, for instance, has been

investing in R290 green cabinets since 2008 and began applying these to the Chinese market in 2009. Red Bull began purchasing ECO-coolers using hydrocarbons as a refrigerant at the end of 2013 in China. ECO-coolers combine the use of hydrocarbons and additional technical improvements (LED lights, energy efficient fans, intelligent controllers, etc.) to save up to 45% of energy compared to conventional HFC-based equipment.

As a leading ice cream manufacturer in China, Unilever is also applying hydrocarbons as a refrigerant in their units. At the beginning of 2015, Unilever had more than 120,000 hydrocarbon-based freezers on the Chinese market.



Over 3.7 million natural refrigerant-based units worldwide

The Coca-Cola Company, PepsiCo, Red Bull and Unilever have cumulatively placed on the market over 3.7 million units of HFC-free refrigeration equipment around the world. In addition to signing up to the commitment to phase out HFCs under the Consumer Goods Forum, they have joined forces under an international initiative ‘Refrigerants, Naturally!’, which promotes the use of natural refrigerants as replacements to harmful greenhouse gases. The Coca-Cola Company has increased their number of HFC-free units by 20% in 2014 as compared to 2013, reaching 1.4 million units in total. The company has certified 230 different CO₂-based models. PepsiCo has placed 240,000 HFC-free units in the global market.

By 2014, Unilever has introduced more than 1.8 million hydrocarbon-based freezers globally. Red Bull, active in 166 countries, has converted more than 50% of its cooler fleet to ECO-Coolers, using hydrocarbon isobutane as a refrigerant and, when viable, every new unit purchased uses hydrocarbons. This amounts to over 543,000 units, two thirds of which are placed in Europe.

Global policy initiatives influencing decisions of China's HVAC&R industry

Besides the voluntary initiatives of global consumer brands, legislative action in different regions is another key driver for the Chinese manufacturing industry in moving toward natural refrigerants in light commercial refrigeration. The regulations that introduce restrictions on the use of HFCs in countries, to which Chinese companies export, have a direct impact on their investment decisions.

In particular, the EU F-Gas Regulation that came into effect in 2015 will have a huge effect on the Chinese HVAC&R industry. The Regulation foresees a ban on the use of fluorinated gases (GWP > 150) in stand-alone commercial refrigeration equipment as of 2022. Moreover, starting in 2017, pre-charged equipment imported into EU will need to be accounted for under the HFC phase down, which will gradually reduce the amount of HFCs placed in the EU by 79% compared to 2009-2012 levels.

Similarly, the US Environment Protection Agency is considering prohibiting the use of some high GWP refrigerants, including R134a, in new stand-alone refrigeration units and vending machines. A proposal published mid-2014 suggests that this prohibition could come as early as 2016. In addition to this, new US energy standards for 2017 pose a weighty challenge for system manufacturers. For example, the standards would require 57% less energy consumption of an upright glass door freezer.

With the global trend toward low-GWP solutions and increasing demand from end users, the Chinese industry is being encouraged to increase technology investment in natural refrigerant-based solutions. In addition, the growing demand of local end users is attracting more foreign companies to supply equipment to the Chinese market.

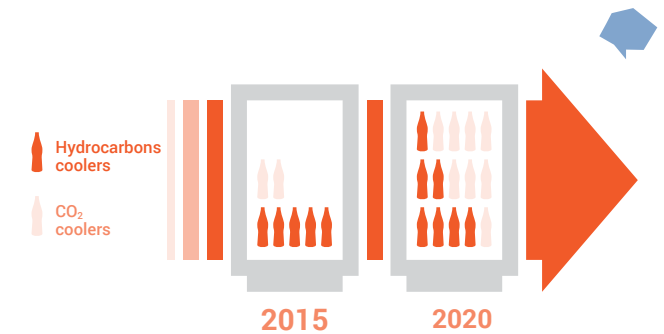

The odds are stacked in favour for mass-adoption of CO₂ and hydrocarbons

Respondents were asked to give natural refrigerant applications marks out of five for their current business and policy climate. The use of hydrocarbons and CO₂ in light commercial refrigeration are currently viewed roughly equally, scoring 3.4 and 3.2 respectively. When ranked alongside the other 11 applications, hydrocarbons and CO₂ in light commercial refrigeration are ranked fifth and sixth, respectively, showing a steady position.

The respondents view the progress by 2020 as similar in terms of ranking with other applications with CO₂ and hydrocarbons in light commercial ranked sixth and seventh, respectively. This shows industry confidence that both CO₂ and hydrocarbons will play an important role in China's light commercial refrigeration, such as bottle coolers, vending machines and plug-in freezers.

Alfa Laval Optigo™

5 models, 3 families, 1 brand



Experience the Alfa Laval advantage

With the Alfa Laval Optigo range you get a higher and more effective cooling capacity with lower power consumption. One range for all commercial cold room storage, from supermarkets to restaurants and groceries. All products are simple and straightforward to install and exchange. And they are also available for high-pressure CO₂.



Visit www.alfalaval.com/refrigeration to learn more.

For high performance
Alfa Laval Optigo™ CC254 & CC403



Plug and play cooling
Alfa Laval Optigo™ CS200 & CS300



Double airflow
Alfa Laval Optigo™ CD304



www.alfalaval.com

Exclusive interviews - Light commercial refrigeration



HOW DO YOU EVALUATE THE MARKET FOR HYDROCARBON-BASED TECHNOLOGY IN LIGHT COMMERCIAL REFRIGERATION UNTIL TODAY?

**Pedro Olalla,
Huayi Compressors:**

China already has a long experience in the use of hydrocarbons for household refrigerators, but now we are seeing the same trend in our market, light commercial. Hydrocarbons are today more present in the sector of ice cream conservators but step by step it is starting to expand to other sectors like supermarket equipment, coolers and beverage dispensers.

**Mogens Søholm,
Secop:**

There is a wide variety of applications that will significantly benefit from the introduction of hydrocarbons due to hydrocarbon's energy efficiency which is normally significantly higher than for HFC's. Moreover, the size of compressors are becoming smaller which gives hydrocarbons a more competitive cost structure at the same time as higher energy efficiency levels.

WHAT DO YOU THINK WILL BE THE MARKET FOR HYDROCARBONS IN LIGHT COMMERCIAL REFRIGERATION BY 2020?

**Pedro Olalla,
Huayi Compressors:**

I'm convinced that hydrocarbons will become the main refrigerant for light commercial refrigeration in China by 2020. Between all the options we have considered, we believe that propane will be selected as the main refrigerant. We can already see an important number of manufacturers going in this direction i.e. developing new projects using hydrocarbons to replace HFCs and HCFCs.

WHAT ENERGY SAVINGS CAN BE ACHIEVED BY USING NATURAL REFRIGERANTS AS OPPOSED TO HFCS OR HCFCs IN LIGHT COMMERCIAL REFRIGERATION?

**Linda Zhang,
The Coca-Cola Company:**

The test results indicate that system design is the main driver to reduce energy consumption. At the refrigerant level, CO₂ is slightly better than R134a.

**Pedro Olalla,
Huayi Compressors:**

Hydrocarbons are much more efficient than HFCs and HCFCs. In our experience, we have seen improvements up to 30% efficiency gains. Beside the low ODP and GWP of hydrocarbons, the other main advantage is that they allow us to reduce the energy consumption and hence the emissions of CO₂ to the atmosphere.

**Mogens Søholm,
Secop:**

This is a difficult question to answer in short, since it depends a lot on the application type and the system design. But energy savings of 30-40% compared to "traditional" HFC based system is absolutely normal.

WHAT STEPS ARE YOU PLANNING TO TAKE TO ADDRESS THE LACK OF TRAINED PERSONNEL AND ENSURE SAFE OPERATION OF NATURAL REFRIGERANT-BASED SYSTEMS?

Linda Zhang, The Coca-Cola Company:

We have arranged training for our bottlers and suppliers in China in order to develop skills in handling the CO₂ refrigeration equipment. We are confident that safety can be assured after we fully migrate to CO₂-powered cold drink equipment.

John Sears, Unilever:

We usually set up training in countries where there is very little understanding of hydrocarbons-based technology to ensure safety. As a result of this initiative and other training programmes out there, it is slowly becoming more common to find hydrocarbon-trained technicians.

WHAT TIPS OR ADVICE WOULD YOU GIVE TO OTHER END USERS WHO ARE PLANNING TO USE NATURAL REFRIGERANT TECHNOLOGY IN CHINA?

Linda Zhang, The Coca-Cola Company:

CO₂ is the technology to go for. We are openly sharing technical information, and the door is open for other companies to use our system designs.

John Sears, Unilever:

It is imperative that as an end user planning to use natural refrigerant technology in China, you ensure that you partner up with the right service organisation.

WHAT ARE THE REMAINING CHALLENGES SLOWING OR IMPEDING THE ADOPTION OF NATURAL REFRIGERANTS IN CHINA?

Linda Zhang, The Coca-Cola Company:

The main challenge we are facing is the incremental cost of transitioning from HFC technology to CO₂ technology. As scale will be key, we are looking forward to having more industry peers to join us in this initiative. Government incentive policy will help to accelerate the overall process.

Another challenge is that for some smaller size coolers of less than 250L, the use of CO₂ refrigeration creates significantly higher incremental cost, which will damage the value chain. At the moment, we are working with our partners to develop HFC-free technology to narrow down the cost increase for coolers between 50-250L in sizes to improve the business case.

John Sears, Unilever:

In our rollout of hydrocarbons-based equipment, we no longer see any barriers to the use of natural refrigerants in China.

New innovation products for environmental-protection: Panasonic CO₂ 2-stage rotary compressors

INTRODUCTION

In recent years, the ozone depleting and global warming effects of fluorinated refrigerants have become a greater concern to the public. Among the alternative refrigerants available is the natural refrigerant CO₂ which is a non-ozone-depleting refrigerant, has a global warming potential (GWP) of 1, is non-flammable and also non-toxic. CO₂ has recently grown in popularity as a refrigerant and has been successfully commercialised. Panasonic has developed the world's first CO₂ 2-stage rotary compressor, which has been used widely in the following applications: vending machines, commercial refrigeration, supermarket show cases, heat pump water heaters and heat pump clothes dryers.

ABOUT THE SYSTEM

The CO₂ compressors made by Panasonic are designed with a 2-stage rotary compression mechanism, including the 15F, 20F and 33F three series. The first stage compression unit intakes the low pressure CO₂, compresses it and discharges intermediate pressure into the shell. From the shell, the intermediate CO₂ is discharged out to the cycle and returned to the second stage compression unit, which compresses it to the final pressure and discharges it to the gas cooler directly.



Panasonic
Panasonic Appliances Compressor (Dalian) Co., Ltd.

Panasonic

<http://papcdl.panasonic.cn>

Jiwei Hu

hujawei@papcdl.panasonic.cn

ABOUT THE COMPANY

Panasonic Appliances Compressor (Dalian) Co., Ltd is a Sino-Japanese company established in 1994. Their product line includes semi-hermetic compressors for commercial refrigeration and scroll compressors for commercial air conditioning. With Panasonic's products being sold to 29 countries worldwide, the company has become a world-wide supplier for many leading manufacturers. With global sales of over 700,000 CO₂ 2-stage rotary compressors, these compressors have proven their excellent efficiency and reliability.

MAIN CHARACTERISTICS AND ADVANTAGES

- » Unique 2-stage rotary compression technology, high efficiency, low vibration.
- » Internal intermediate & high pressure design
- » High efficiency DC inverter drive with a range from 40Hz to 100Hz
- » High Reliability, light-weight and compact
- » Wide operation range

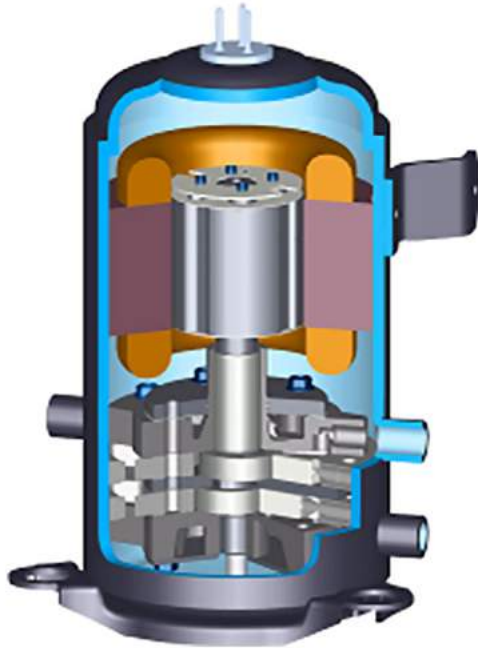

CHARACTERISTICS OF THE 2-STAGE CO₂ COMPRESSOR

- » **High efficiency:** By dividing the compression load into 2 compressions, the leakage at the seal is reduced so that high compression efficiency can be achieved.
- » **Minimised noise and vibration levels:** Equalisation of the twin rotary compressor's torque is achieved thanks to the compression mechanism's 2-cylinder structure in which the two cylinders face each other at 180 degrees, minimising vibration and noise.
- » **Light-weight design:** Internal intermediate pressure design enables the shell wall thickness to be 35% thinner than that of a high internal pressure design. This contributes to the compressor's low weight that is almost the same as a conventional R410A compressor.
- » **Easy design:** The adoption of an inter cooler or economiser is one of the biggest merits of the 2-stage compression in a transcritical CO₂ cycle, which helps improve the system performance and reduce the discharge temperature.

Panasonic

Panasonic Appliances Compressor (Dalian) Co., Ltd.



XV Compressor for R600a – A new standard for cool savings

INTRODUCTION

Danish Technological Institute (DTI) has, together with EUFP and producer Vestfrost Solutions, made comprehensive energy tests of commercial wine coolers. Results show that the variable speed Secop XV5.OKX compressor for R600a ensures a 47% overall energy savings compared to wine coolers with fixed speed compressors.

ABOUT THE SYSTEM

Secop's XV Compressor – a new standard for cool savings

Design and usability are important matters in the light commercial market, but above all these ranks cost-efficiency. Refrigerators, freezers and coolers are always in use, which is why improved energy efficiency along with increasing environmental standards is so essential to the business.

Together with DTI and EUDP – a programme that furthers new energy-friendly technologies – the Danish producer Vestfrost Solutions made numerous tests, both in laboratories and 'real life' in order to ensure that their new wine coolers also would set a new standard for energy savings.

Wine cooler + XV compressor with variable speed = Up to 47% energy savings

The criteria included a compressor that could combine high performance and low energy consumption with temperature precision and low noise. Tests demonstrated that the Secop XV5.OKX was a very good match.

In contrast to traditional fixed compressors, the XV5.OKX is able to adjust the supplied cooling capacity of the compressor to the required cooling capacity of the cabinet by operating at different speeds. This rules out the constant stop-and-go-motion and leads to a more balanced cooling temperature and reduces energy consumption considerably. Results showed that the Secop XV5.OKX compressor managed the same high performance as the fixed compressors but used 36% less energy.



Secop
www.secop.com

Pieter Boink
p.boink@secop.com

ABOUT THE COMPANY

With more than 50 years of experience in compressor technology and highly committed employees, Secop's focus is to develop and apply their advanced compressor technologies to achieve a standard-setting performance for leading products and businesses around the world.

Secop are already well-established within the manufacturing and sale of compressors in China and are determined to challenge their Chinese competitors in this increasingly important market.

Best in class + Best in fit

The XV compressor made the Vestfrost Solutions wine cooler take a best-in-class-leap from energy efficiency class B to energy efficiency class A+ and simultaneously provided improvements on noise levels – an instrumental feature when choosing wine coolers.

Furthermore, the compressor was able to demonstrate great flexibility. Due to its extremely small size and weight, it only took minor adjustments to make the Secop compressor fit within the pre-existing cabinet. With the XV5.OKX, it is possible to reduce energy consumption without the need for big design changes to the appliance.

The Secop XV Compressor – Small is the new big

Secop's XV compressor is showing that you don't need to be big to be powerful, with the following specifications ensuring this compressor has all the capabilities of a larger compressor, but with the added value of being compact:

- » Used in applications with evaporating temperatures of -35°C to 0°C
- » Height of 100mm and weight of 4.8kg
- » Low noise of 32 dB(A)
- » Broad dynamic range (1:4)
- » Up to 40% efficiency gain
- » Up to 20l extra storage volume in cooling cabinets
- » Adaptable capacity

A big part of the XV compressors secret is its unique external rotor motor that enables the use of much larger magnets, ensuring a superior compressor efficiency. Another big part of the secret is the know-how that goes into the assembly process. The key is the modular design of the XV compressor, combining the advantages of standardisation with those of customisation. On top of that, the compressor is uniquely assembled without any screws whatsoever. This new kind of construction also allows for a reduction in the use of the traditional and expensive copper material.

SUMMARY

A new cool for wine coolers

Vestfrost Solutions has been pleased with the outcome and so have the different end-users who have already had the opportunity to try out the 'upgraded' wine coolers. They mention the new cooling qualities as something to look out for and, naturally, the prospect of saving both energy and total costs.

“*The XV5.OKX is the perfect choice for a wine refrigerator, because it is able to work both in low back pressure and medium back pressure ranges. It is very efficient thanks to its wide dynamic range. Its cooling capacity is adjustable from low to high demand with little vibration and noise.*”

– Jürgen Gläser - Senior Application Engineer and System Specialist at Secop GmbH



SECO P

Heat pumps

Introduction

As it stands today, CO₂ heat pumps have quickly emerged as one of the most dynamic markets for the use of natural refrigerants in China in recent years. This is particularly the case for their use in commercial applications, such as in public buildings, train stations, hospitals and universities.

The unprecedented public concern over environmental protection has been a strong impetus to accelerate heat pump adoption across the country. In addition to China's conventional market for CO₂ heat pumps in commercial applications, the launch of CO₂ heat pump water heaters for residential applications and the expansion into industrial applications in the Chinese market in 2014 marked yet another development phase of CO₂ technology. With increased interest from foreign suppliers, Chinese local manufacturers are currently trialling CO₂ technology, with more than 300 commercial R744 units running throughout the country. Once the industry is confident in the technology, one can expect CO₂ heat pumps in China to enter a rapid development phase.

The survey results support these assumptions, providing a positive outlook for the R744 heat pump market. Expectations by Chinese and international market players point toward continued growth until 2020.

However, the current business and policy frameworks still need to be strengthened for the market to develop more effectively. Among the priorities to accelerate market adoption are an increased number of and access to such products in China - especially by growing the supplier base for providing the components and systems. For this to happen, government subsidies and other non-financial policy support in the early stages of market development are necessary. The effectiveness of such measures can be seen in other countries, such as Japan, where CO₂ heat pump water heaters in residential applications mark one of the most successful stories for natural refrigerants usage worldwide.

More than 300 CO₂ heat pumps operate in China. Commercial heat pumps are a key driver to expand R744 use into other applications.

The CO₂ heat pump market is expected to be one of the most dynamic markets for natural refrigerants between today and 2020.

CO₂ heat pumps

MOST SUPPLIERS STILL IN TESTING PHASE
– STRONG MARKET GROWTH EXPECTED

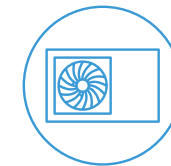

300+
CO₂ transcritical
commercial heat pumps
(13 suppliers)

The current demand: Commercial heat pumps key to success

According to shecco's primary market data collection from thirteen leading suppliers, there are more than 300 units of CO₂ heat pumps in commercial and industrial applications in China today. The first market created for CO₂ heat pumps in China has hence been in commercial applications as to the residential sector. In hospitals, train stations, schools and public buildings, CO₂ heat pumps have been adopted to cover the entire cooling and heating requirements at a high level of energy efficiency. This has been shown in some of the cases presented in the 'Eco-systems' chapter of this report, where R744 has been the preferred choice for producing sanitary hot water at harsh ambient temperature conditions and elevation levels, while reducing energy consumption between 50-80% as compared to electric boilers.

Looking to the future: 50,000 CO₂ heat pumps by 2020?

The success of CO₂ heat pumps in commercial applications is spurring further investment in larger applications such as in the industrial sector. At the same time, the market expanded in terms of both scale and variety when a domestic manufacturer launched the first CO₂ heat pump water heater for residential application in September 2014.

The findings from the individual interviews conducted by shecco with key heat pump manufacturers show that the present number of R744

CO₂ heat pumps have especially attracted the Chinese industry's attention due to their reliable and efficient operation at challenging outside temperatures; they can work in ambient temperatures as low as -25°C and as high as 43°C. Adaptability to different ambient temperatures means CO₂ heat pumps are well suited to China's different climate zones, which range from the cold northern region to a warm climate in the south.

What is more, CO₂ heat pumps can also produce higher temperature hot water compared to conventional heat pumps, up to 90°C compared to 55°C. This is especially attractive for applications where hygiene and safety are paramount, such as in sanitary hot water production or drinking water.

heat pumps in the country has been the result of an active testing and trialling phase to verify the viability of CO₂ technology for residential and commercial use with a view of commercialising the products in 2015. It could be expected that the introduction of CO₂ heat pumps in China will gain an accelerated pace once the products are commercially available and new suppliers enter the market.

According to an exclusive interview shecco con-



...of respondents expect the use of natural refrigerants in heating will...

increase by 2020

remain the same by 2020

decrease by 2020

Number of respondents: 536

Chinese industry provides a sunny forecast for CO₂ heat pumps

When asked about the future use of natural refrigerants in heating, 71% of respondents replied that they believe the use will increase by 2020 in China, while 22% expect it to stay the same. Only 7% expected the use of natural refrigerants to decrease by 2020 in the heating sector.

The recent technological developments made in CO₂ heat pumps have led to positive expectations for the future in China. With Japanese companies also looking to supply their own products to China, the market is primed to be competitive.

ducted with a leading local CO₂ heat pump manufacturer, in the next decade, the market share of CO₂ heat pump has the potential to reach 5% and there could be 50,000 CO₂ heat pumps installed in the country by 2020.

Market development for R744 water and space heating equipment needs to be analysed against

the backdrop of growing heat pump sales overall. According to an industry forecast, the heat pump market in China is going to grow at a CAGR of 27.86% during 2013-2018 to match the increasing demand driven by an increased concern over environmental protection.

Major drivers: Adapting to China's climate zones and increasing efficiency

The remaining challenges the industry faces before market adoption can be fully realised include: research into the properties of CO₂ to maximise its energy efficiency, investing in state-of-the-art components such as compressors and heat exchangers, and fully exploiting R744 models' potential to be adapted to the different climatic regions across China.

In September 2012, the Chinese Ministry of Science and Technology held a seminar on technological development and industrialisation of CO₂ heat pumps in China. As a result of this seminar, the programme 'CO₂ Heat Pump Core Technologies and Industrialisation' was created in the

Chinese province of Guangdong as part of the 'National Science Technology Support Plan Project' which is contained in China's 11th Five-Year Plan. The programme's aim is to remove market barriers for CO₂ heat pumps, especially technological obstacles. This is done through supporting universities and private research companies working with CO₂ heat pumps. Thanks to this programme, several Chinese manufacturers have mastered the core technology of CO₂ heat pump water heaters, such as rotary compressors and heat exchangers that can be used both in heat pump water heaters and commercial refrigeration applications.

China's national plan: CO₂ heat pumps a key technology for energy savings

In China's 12th five-year plan for energy saving and sustainable industry development in 2012, CO₂ heat pumps were listed as a key technology

that can lead to energy savings in the industry. More recently in 2014, the provincial government of Guangdong stated in a document addressed to

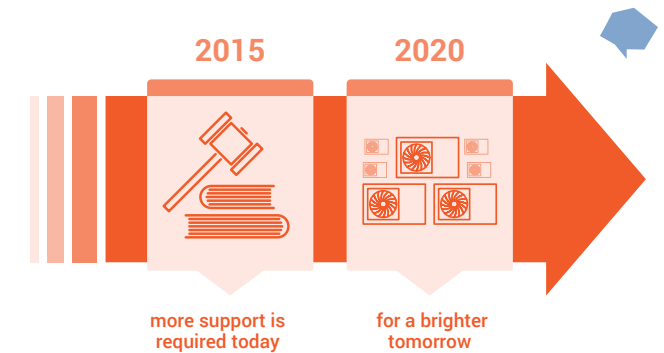

Number of respondents: 539

Present market requires government support to reach future expectations

When asked how they rank the current policy and business climate of CO₂ heat pumps compared to other applications that use natural refrigerants, the respondents were not glowing in recognition. It was ranked seventh (3.2 out of 5) out of 11 applications using natural refrigerants. However, it is expected to improve, with this application ranked fifth (3.6 out of 5) out of 11 for the application with the most potential for natural refrigerants in 2020; showing that future growth is expected for this market.

While optimism is rife for the future for CO₂ heat pumps, there still remains, at present, a bridge that needs to be built to accommodate this growth. With Japan as the model, it can be seen that the involvement of the government in the form of subsidies and allocations for R&D is paramount to the future development of the market.

the State Council that CO₂ is a suitable refrigerant for use in different residential applications.

On 29 September 2014, the Chinese National Development and Reform Commission released its regulation for an energy efficiency label for heat pump water heaters, through which it aims to improve energy label information targeted to the general public. The regulation has been active since. The industry believes that the government and general public's increasing interest in the energy efficiency of heat pumps will eventually lead to a phase out of low-efficiency heat pumps and a shift to high-efficiency models such as CO₂ heat pumps.

As a complementary development to support the

New Top Runner scheme to promote energy efficiency among Chinese consumers

In January 2015, seven state organisations including the National Development and Reform Commission, Ministry of Finance, Ministry of Information Technology, National Government Offices Administration, and National Energy Administration launched the Energy "Top Runner" System Practice Plan (2014/3001). It allows to display the "Top Runner" label on selected products to help the promotion of energy saving products. Eligible products include: consumer equipment, products in high-energy consumption industries with energy efficiency of level one in national energy efficiency rank, as well as addressing the integration of the latest energy saving components into systems. With govern-

ment's '2014-2015 Energy Saving and Carbon Reduction Emission Action Plan' (2014,23) was released in May 2014. The State Council decided to phase out 50,000 small boilers in 2014 and the equivalent of 200,000 steam tonnes by the end of 2015. In response to the national government's request, local bodies in northern China encourage and subsidise the replacement of conventional coal-fired boilers with water source heat pumps and ground source heat pumps in space heating to mitigate pollution concerns in the region. As a result, the trend towards replacing coal-fired boilers with heat pumps has accelerated in the northern Chinese market.

ment and the general public's increasing interest in the energy saving potential of heat pumps, it is hoped that this will eventually lead to a phase out of low performing heat pumps and a parallel shift to high efficiency R744 models – something that has already helped the market uptake in Japan, where the Top Runner scheme proved to be a highly effective complementary tool to support the government's national strategy for technology adoption.



Japan - the world leader for CO₂ heat pumps with an effective national plan

In Japan, the Eco Cute hot water heat pump using CO₂ as a refrigerant has been a run-away success over the past decade. By the end of February 2015, an impressive 4.7 million units were expected to be installed in Japan alone. Annual sales are now at 400,000-500,000 units per year, reaching a market share of 98% of all new residential heat pump water heaters in the country. By 2020, the Japanese government aims to reach 10 million R744 Eco Cute units. The rapid increase started in 2001 when the country implemented an effective and multifaceted support scheme that still serves as a best-practice example for other national markets. The government's role in raising awareness among market players has been especially instrumental in rapid market adoption. Through energy savings awards, financial support measures for R&D and awareness-raising campaigns, as well as green purchasing laws and consumer subsidy schemes, Japan is now close to its initial target of 5.2 million Eco Cute units by 2010.

Low-GWP label for HP water heaters: the next phase in addressing environmental protection

In March 2015, the Ministry of Environmental Protection, alongside UNEP, UNIDO, GIZ and CHEAA introduced a label to promote products using low global warming substances, including natural refrigerants, in RACs and heat pump water heaters. The label is an important signal to the industry to help increase the share of CO₂ as a refrigerant in heat pump water heaters. Products eligible for the label have to have a level of energy saving in accordance with the national standards. More importantly, the product should have no ozone

depletion potential and a GWP of less than 150.

The move by Chinese and international stakeholders reflects China's awareness of the potential for natural refrigerants to follow global trends regarding environmental protection. It remains to be seen how effective the initiative will be for the promotion of R744 heat pump water heaters among consumers in particular.

Standards to rule the efficiency, noise and safety of heat pumps

In June 2011, the Chinese CO₂ heat pump standard (GB/T26181-2010) was formally implemented. The CO₂ heat pump standard delineates requirements for the compressor cooling capacity, the coefficient of performance and the heat pump's noise levels.

In 2012, the General Administration of Quality Supervision, Inspection and Quarantine and the Standardisation Administration of China released the standard for 'Household and Similar Electrical Appliances - Safety - Particular Requirements for Heat Pumps, Air Conditioners and Dehumidifiers' (GB 4706.32-2012). This standard was drafted by a collaboration between China Household Electric Appliance Research Institute (CHEARI), the Guangzhou CVC Institute of Technology Detec-

tion and representatives from air conditioner and refrigerator/freezer manufacturers.

The standard adopts the International Electro-technical Commission's (IEC) safety requirements for electrical heat pumps, air-conditioners and dehumidifiers containing flammable refrigerants (IEC 60335-2-40:2005). Compared with the previous version (GB 4706.32-2004) which was released in 2005, the 2012 version of the safety standard sets out detailed rules for safe operation relating to safety warning, transportation, installation, storage and charging of flammable refrigerants. The standard applies to heat pumps equipped with electric motors, compressors or room fan-coil units (including domestic hot water heat pumps), air-conditioners and dehumidifiers.

Exclusive interviews - Heat pumps



WHAT ENERGY AND COST SAVINGS CAN BE ACHIEVED BY USING CO₂ AS OPPOSED TO HFCS OR HCFCs IN HEAT PUMPS?

**Massimo Casini,
Dorin:**

It is quite difficult to give fixed figures of energy / cost advantages due to the impact of design concepts and ambient temperatures. But to give an idea of costs and savings, in a CO₂ heat pump installation in a hotel in Shanghai, compared to a conventional fuel boiler, Dorin's system reduced the running cost by 80% and returned the investment in 8 months.

A LABEL TO PROMOTE LOW-GWP RAC AND HEAT PUMPS WAS RECENTLY LAUNCHED IN CHINA TO HELP INCREASE AWARENESS ON CLIMATE FRIENDLY TECHNOLOGIES AMONG CONSUMERS. ARE THERE PLANS FOR OTHER INCENTIVES TO ENCOURAGE END USERS TO SHIFT TO NATURAL REFRIGERANTS IN OTHER APPLICATIONS?

**Zhong Zhifeng,
FECO:**

There is a need to continue increasing awareness of environmentally friendly technologies amongst end users. The government can initiate this process but continuation of these ideas requires all stakeholders such as manufacturers, distributors, the media, government and experts to work together

WHERE DO YOU SEE THE BIGGEST CHALLENGE IN TERMS OF TECHNOLOGY FOR HEAT PUMPS USING NATURAL REFRIGERANTS? AND

**Professor Ma Yitai,
Tianjin University:**

The biggest challenge could be the acceptance of the new technology by the public. For instance, in the case of CO₂, it can be widely used in heat pump water heaters, refrigeration and air conditioning systems. However, due to its high pressure (8-12MPa), components like compressors, heat exchangers, valves, pipes, refrigerant containers, leakage detection and alarm systems need to be designed specifically for the CO₂ refrigerant - something people have not yet gotten used to.

The high operating pressure of CO₂ is not the biggest obstacle. Because CO₂ density is high, the outer diameter of the actual pipe or component is relatively small because the thickness of the wall is enhanced due to CO₂'s high operating pressure, and the internal diameter of the pipe is also reduced. Other than this, the heat exchangers and pipes can be used in CO₂ system without fundamental modification. If the pipes and heat exchangers are produced meeting standards and regulations, then they are strong enough to be applied in CO₂ systems.

**Professor Yang Zhao,
Tianjin University:**

Safety is the biggest challenge as flammability causes safety concerns that could be quashed through policy. If this isn't cleared up, then it will lead to a reduced acceptance by consumers. Removing this barrier is a big challenge, which would need to involve a combination of international and domestic research and business community members companies and end-users.

**Professor Shi Lin,
Tsinghua University:**

One of the technological challenges can be found in optimising the overall efficiency of high-pressure CO₂ systems. Intensified research into R744 high-efficiency compressors is needed, as well as work on enhanced heat transfer and on addressing throttling losses. Interesting research areas also include micro channel heat exchangers and ejectors as two ways to improve efficiency overall and in higher ambient temperature conditions. As regards the use of hydrocarbons, more work needs to go into tackling flammability issues and this includes appropriate risk assessment. Overall, research will continue to focus on the theoretical and experimental research of refrigerants and lubricating oil thermo-physical properties.

INCREASE YOUR VISIBILITY TODAY.

YOUR INDUSTRY NETWORK FOR NATURAL REFRIGERANTS

The world's only industry websites for the natural refrigerants carbon dioxide (CO₂, R744), hydrocarbons (HCs, R600a, R290 etc.), ammonia NH₃, R717) and water (H₂O, R718). From the number one publisher of natural refrigerant information, our websites feature a unique mix of News, Products, and Events, attracting 10,000+ regular readers, including CEOs, Technical Directors, Refrigeration Engineers, End Users, Marketing and Sales Managers, Policy Experts and more.

JOIN AS A PARTNER TODAY TO SHOWCASE YOUR NATURAL REFRIGERANT PRODUCTS & SERVICES.

For benefits and pricing contact us at:

email: sales@r744.com

call: +32 2 230 3700

shecco Publishing 





CO₂ low temperature heat pump heating system

INTRODUCTION

This case study presents the heating system at Panasonic's new motor assembling workshop. The workshop has one floor, with a height of 8.5m, a heating area of 4,140m² and a staff concentrated working area of 1,350m². With a heating capacity of around 140 kW, the CO₂-based system is able to provide heating air to every work station.

ABOUT THE SYSTEM

The system's necessity is partly due to the fact there is no municipal concentrated-heating network surrounding the workshop as well as a limitation regarding the usage of a small coal-fired boiler or oil-fired boiler. The last key consideration is that the efficiency of air source heat pumps using conventional refrigerants is adversely affected in low ambient temperatures. Considering all of the above in addition to environmental integrity, Panasonic adopted the CO₂ air source heat pump unit, which is designed and manufactured by Panasonic for workshop heating.

The overall project combines three elements: a 'CO₂ air source heat pump unit', a "water supplying system" and a "fabric air ventilation system". The system is engineered to supply heating to each working station in Panasonic's workshop, via a centralised automatic-control method. There are a total of six CO₂ air source heat pump units each one unit consisting of four 33F series DC inverter twin rotary compressors, manufactured by Panasonic Appliances Compressor (Dalian) Co., Ltd. The closed-loop water cycling is applied in the water supplying system, with a high thermal efficiency to help reduce the size of the water pump. The warm air is delivered to the air ventilation system through a fan coil heat exchanger, heating every working station appropriately. The PLC and touch screen are used in the heating control system to help realise centralised automatic control. The control system displays and records the operational status for each unit and adjusts the operation of the compressors accordingly, which ensures a reliable, safe and steady operation for the whole system.

Panasonic Appliances Compressor (Dalian) Co., Ltd.

Panasonic

<http://papcdl.panasonic.cn>

Jiwei Hu

hujawei@papcdl.panasonic.cn

ABOUT THE COMPANY

Panasonic Appliances Compressor (Dalian) Co., Ltd is a Sino-Japanese company established in 1994. Their product line includes semi-hermetic compressors for commercial refrigeration and scroll compressors for commercial air conditioning. With Panasonic's products being sold to 29 countries worldwide, the company has become a world-wide supplier for many leading manufacturers. With global sales of over 700,000 CO₂ 2-stage rotary compressors, these compressors have proven their excellent efficiency and reliability.

RESULTS

With a diminished use of lower heating capacity due to the implementation of the system, the heating efficiency of air source inverter heat pumps are high in low ambient temperatures. The split design, which has an outdoor unit, helps save space and is also easy to install, meaning there is no need for a machine or a boiler room. The system was put into use on November 2012 and since then, the system has been operating well, with a good overall heating performance. Based on this field test, which was conducted in winter, the average heating efficiency of CO₂ air source low temperature heat pump is markedly higher than the previous electric heating system.

Panasonic

Panasonic Appliances Compressor (Dalian) Co., Ltd.



CO₂ heat pump water heater system

INTRODUCTION

In the staff living quarters of Panasonic Appliances Compressor (Dalian) Co., Ltd. a CO₂ heat pump system is used to provide hot water for security guards working the night-shift. The system is designed to accommodate 10 staff per day, assuming 100L hot water usage per staff member with the capacity of hot water tank of 1.1m³.

ABOUT THE SYSTEM

Previously, an electric boiler was used to supply hot water, which consumed more power and also suffered from scale formation within the system alongside other safety hazards contributable to the combination of electricity and water. The economical nature of air source heat pump water heaters was recognised as the perfect solution to replace the troublesome electric boiler. The use of CO₂ in the heat pump is essential due to the northern location of Dalian, where the rated ambient temperature for heat pumps in winter is -12°C, and the minimum ambient temperature is -20°C. Therefore, heat pump water heaters that use conventional refrigerants cannot work efficiently under these conditions. As such, as an alternative, this system utilises CO₂ air source heat pump water heaters, designed and manufactured by Panasonic. Compared with heat pump water heaters using conventional refrigerants, the CO₂ system is environmentally friendly and also has higher average hot water temperatures and lower capacity decreases in low-ambient temperature conditions.

Panasonic

Panasonic Appliances Compressor (Dalian) Co., Ltd.

Panasonic

<http://papcdl.panasonic.cn>

Jiwei Hu

hujawei@papcdl.panasonic.cn

ABOUT THE COMPANY

Panasonic Appliances Compressor (Dalian) Co., Ltd is a Sino-Japanese company established in 1994. Their product line includes semi-hermetic compressors for commercial refrigeration and scroll compressors for commercial air conditioning. With Panasonic's products being sold to 29 countries worldwide, the company has become a world-wide supplier for many leading manufacturers. With global sales of over 700,000 CO₂ 2-stage rotary compressors, these compressors have proven their excellent efficiency and reliability.

SPECIFICATIONS

- » **Compressor:** 33F series CO₂ DC-Inverter twin rotary compressor, manufactured by Panasonic, which has minimal vibrations and noise as well as a high efficiency.
- » **Evaporator:** Copper pipe-aluminum fin heat exchanger with a small pipe diameter design which improves the pressure endurance performance and also decreases refrigerant consumption.
- » **Expansion Valve:** Electronic expansion valve with real-time control by PLC based on the system operation parameters.
- » **Gas Cooler:** Double-pipe heat exchanger. The pipe has been under intensified processing, improving the heat exchange efficiency with low flow resistance.

The outlet hot water temperature is designed to be adjusted according to seasonal requirements. The system efficiency can be further improved by decreasing the settings of outlet water temperature when the heating load is lowered. The system is equipped with a water-soften module to avoid scale formation.

RESULTS

- » **Safety and reliability:** Compared with the electric boiler, the CO₂ heat pump water heater isolates the water from electricity, which reduces risk. Regarding the system's control, there is a discharge temperature thermostat and high-pressure switch, which protects the system in abnormal conditions.
- » **Performance:** The hot water temperature can reach >65°C even under -12°C ambient temperature, which is an incomparable advantage over heat pump water heaters using conventional refrigerants. Thanks to the inverter and optimising control technology, the heating capacity has no temperature fluctuations compared with the capacity under higher ambient temperature. Energy consumption is also 50% lower than a traditional electric boiler.
- » **General Performance:** The CO₂ air source heat pump water heater is reliable, safe, easy to control and has an outstanding energy efficiency performance.

Panasonic

Panasonic Appliances Compressor (Dalian) Co., Ltd.

Room air conditioning

Introduction

Last year (2014) represented an important transition phase for the expanded use of natural refrigerants in China's room air conditioning (RAC) industry. Several production lines for room air conditioners and compressors were converted to produce hydrocarbon refrigerant-based models, while the government introduced a subsidy scheme to support the uptake of propane (R290) RAC systems.

In 2015, further advancements are expected to unlock the full commercialisation potential of R290 in RACs in China, increasing both the domestic and international market for such applications. The industry survey results reveal that the market for R290 RAC units is expected to grow by 2020.

Recent developments, however, suggest that China - as a world leader in supplying air conditioning systems to the international market - has shifted its attention towards less sustainable refrigerants, satisfying emerging needs from developing and developed countries. This is also confirmed by the industry survey results, where, in terms of current business and policy climate, as well as the market potential until 2020, the evaluation for hydrocarbons in domestic air conditioning is not as positive as in other applications.

Another major set-back for the Chinese industry's capacity to invest in a faster roll-out of R290 air conditioners is highlighted by the existing safety concerns plaguing the production, installation and maintenance of hydrocarbon technology. Detailed safety regulations on the installation and maintenance processes need to be finalised in order for industry to move forward. Lastly, the training of personnel to handle the system and the proper understanding of the safety measures and benefits of R290 in RACs should be conveyed to the consumers. In a nutshell, the Chinese R290 RAC market seems to have stalled and will only accelerate once effective regulation, standards and training have been implemented.

The conversion of production lines will make China a theoretical leader in R290 RAC production, with an annual capacity of 4.5 million units.

Active policy support, safety regulations, and stronger industry commitment are needed to unlock China's full R290 RAC market potential.

Gears in motion for shift to R290 in RAC



Strong support for more than a decade puts China in the driver's seat for R290 RAC today

So far, the technology for R290's usage in RACs has been developing rapidly in China. The uptake of R290 technology for rotary compressors in China started more than a decade ago, in 2004. Investment in R&D for R290 compressors was complemented with financial support from the Chinese government under the National Programme. With the support of the UN Multilateral Fund of the Montreal Protocol, the first demonstration production line for R290 compressors was implemented in 2011.

In December 2008, the first unit of R290 RAC developed by a local RAC manufacturer was approved by the China Household Electrical Appliances Association (CHEAA). In 2009, the Ministry of Environmental Protection, in cooperation with CHEAA and international development agency GIZ provided financial support to domestic RAC manufacturers in the conversion of production lines, achieving an annual production capacity of 100,000 units. The first series of R290 RACs were exported to the Maldives in 2011.

Conversion plans boost HC RAC production capacity to 4.5 million units per year

2014 was an important year for R290 in RACs in China. According to the 'International Workshop on Alternative Technology on HCFC-22 in Room Air-Conditioning Sector', held in November 2014 in the Zhejiang province, the conversion of production lines to R290 adds up to approximately 4.5 million units of annual production capacity in China. With the support of the Multilateral Fund of the Montreal Protocol (MLF) there are currently two compressor production lines converted to R290, with another two conversions of compressor lines ongoing. For the production of RAC systems, three lines are finished to accommodate for the manufacturing of R290 models, with the current annual production capacity of 400,000 units. The conversion of another 13 lines is in progress, while an additional four will be initiated soon. Besides the conversions of production lines

supported by the MLF and GIZ, one manufacturer has converted one of its production lines to R290.

According to a leading rotary compressor manufacturer in China, the majority of R290 R&D and manufacturing is currently taking place in China. As a global supplier for RAC compressors and systems, the conversion to R290 has the potential to exert a significant global impact. China accounts for 85% of the global production capacity of unitary air conditioning. In addition to this, China supplies 90% of the world's rotary compressors, which are commonly used in RAC. Therefore, alongside RAC conversion, the conversion of compressor production lines would greatly accelerate the penetration of R290 in the global RAC market.



...of respondents expect the use of natural refrigerants in air conditioning will...

increase by 2020

remain the same by 2020

decrease by 2020

Number of respondents: 536

Optimism for Chinese R290 RAC market

The overwhelmingly positive message from the survey was that the Chinese industry considers the future use of natural refrigerants in RAC a real likelihood. This can be seen by the fact that 80% of respondents believe the use of natural refrigerants will increase in room air conditioning by 2020, with 15% believing it will remain the same and, 5% believing it will decrease by 2020.

This outlook can be attributed to the ongoing conversion of traditional RAC models to those that use R290. Success stories from other regions, such as India, show how popular R290 RAC can become in a short period of time and this could be seen as an end-destination for the Chinese market.

cubigel[®]
compressors

Live
the **Cooling**
Experience



As leaders in the production of compressors for commercial refrigeration, Cubigel Compressors[®] products offer remarkable efficiency ranges of compressors and condensing units. The solutions of Cubigel Compressors[®] are supported by European development and focus on product innovation strategy with comprehensive industry experience. The company has been in the market for more than 50 years and it is part of the Huayi Group, the world's leading manufacturer of hermetic compressors.

As a result, our customers can enjoy an ultimate experience in which quality, service, technology and innovation come together.



cubigel[®]
compressors
by
HUAYI
COMPRESSOR
BARCELONA

Live the **cooling** experience

Safety and training of utmost importance to accelerate the market

One challenge for the Chinese industry to fast-track the rollout of R290 air conditioners lies in the remaining safety concerns for the handling of hydrocarbons. This specifically refers to introducing detailed safety regulations on the installation and maintenance process, as well as investing in the training of personnel to handle the system and to properly understand all necessary safety measures and benefits of R290 in RAC.

In order to guarantee that flammable refrigerants are handled securely, GIZ provided training courses for technicians, as well as step-by-step installation guides. Chinese R290 models were adapted to meet European safety and energy efficiency criteria for the use of hydrocarbons as a refrigerant. In September 2010, R290 RAC was approved by Germany's VDE (Association for Electrical, Electronic & Information Technologies) to enter the European market.

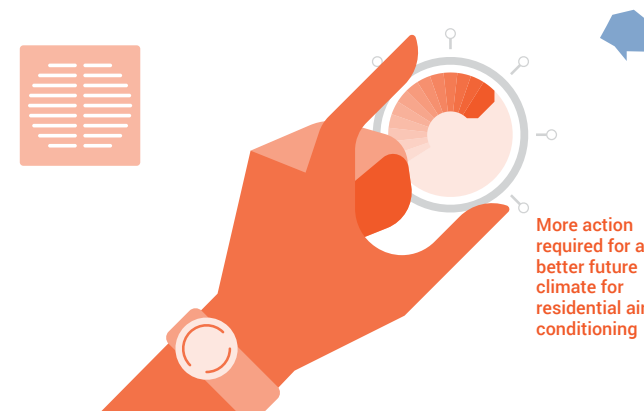

More action required for a better future climate for residential air conditioning

Number of respondents: 536

Policies and training will be a much needed breath of fresh air

Future expectations are high for R290 in RAC, with the potential for its adoption by 2020 scoring an average of 3.4 compared to its rating of 3.2 (out of 5) for its current business and policy climate. This places the use of R290 in RAC in the future as the eighth best application out of 11 compared to the present case where it is ninth out of 11.

The recent introduction of state subsidies for R290 RACs alongside international assistance in converting both RAC and compressor production lines, will help both demand and supply. In addition, the finalisation of detailed safety regulations related to production and maintenance, as well as the focus on training, will be key in moving the market for R290 RAC forward in China.

China supports R290 RAC manufacturers with subsidies

In 2014, the Chinese government demonstrated strong support for the development of R290 technology. In April 2014, as part of 'Room Air Conditioning Industry HCFC Phase-out Management Action Plan', the Chinese Ministry of Environmental Protection published a list of nine RAC manufacturers eligible to receive incremental operating cost subsidies, to help cover both the cost to companies of transforming RAC production lines to R290, and the increased cost of producing each R290 unit for the first year of production.

Support levels amount to:

- » Portable units: first 10,000 produced before 31 December 2015 will receive ¥360 (€43). After 10,000 units the subsidy is reduced to ¥300 (€36). After 1 January 2016 the subsidy

is reduced again to ¥150 (€18), and then on 1 January 2018 to €0.

- » Window units: first 10,000 produced before 31 December 2015 will receive ¥155 (€19). After 10,000 units the subsidy is reduced to ¥125 (€15). After 1 January 2016 the subsidy is reduced again to ¥63 (€7), and then on 1 January 2018 to €0.
- » Dehumidifier units: first 10,000 produced before 31 December 2015 receive ¥150 (€18). After 10,000 units the subsidy is reduced to ¥120 (€14). After 1 January 2016 the subsidy is reduced again to ¥60 (€7), and then on 1 January 2018 to €0.

Label for low-GWP refrigerants to raise consumer awareness

In March 2015, the Ministry of Environmental Protection along with UNEP, UNIDO, GIZ and the China Household Electric Appliance Research Institute (CHEAA), introduced a label to promote products using natural refrigerants and other low-global-warming substances in RAC and heat pump water heaters. The label is a direct incentive for the industry to promote the use of R290 in RACs. The selection criteria specify that

the product should be considered energy saving under national standards. More importantly, the product needs to operate with zero ODP and less than 150 GWP substances.

As in the heat pump sector, it is hoped the label will increase public awareness on environmental protection and help promote sustainable air conditioning technology in the Chinese market.

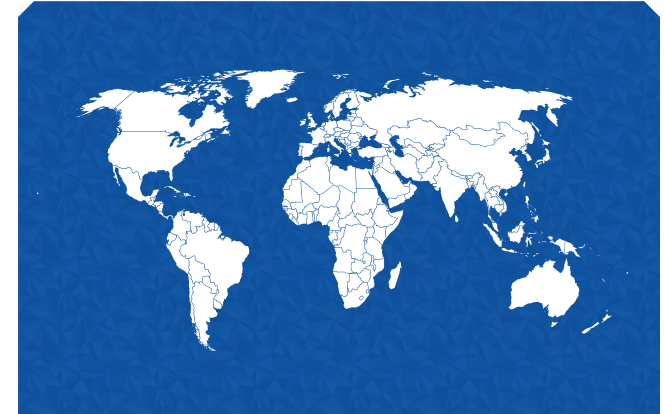

India reaches 100,000 RAC units with R290

In India, R290 RACs are on the path to becoming a true success story, with sales reaching 100,000 units in 2014. The units developed by an Indian manufacturer save up to 10% in energy usage as compared to best-in-class five-star rated air-conditioners. The local producer is now on track to reach its maximum annual production capacity of 180,000 units for R290 RACs in India. With a market share of 13% in the five-star AC segment in India, the move propelled the producer to become the number three brand in this area. Due to the lack of clear regulations in India related to the use of flammable refrigerant in RACs, and the absence of national standards, relevant European standards such as EN1127-1 were adopted. To monitor product safety and reliability, the manufacturer operates a database systematically recording complaints and faults. From the database, R290 RACs in the Indian market have a fault rate of <0.5% per year, with an excellent reliability and safety record.

Standards for household appliances to address safety aspects

The national safety standard for household appliances includes products using flammable refrigerants (GB 4706.32-2012), "Household and similar electrical appliances – safety – particular requirements for heat pumps, air-conditioners and dehumidifiers," entered into force in May 2013. The standard was drafted by China's Household Electric Appliance Research Institute CHEARI, the Guangzhou CVC Institute of Technology Detection and representatives from air conditioner and refrigerator/freezers manufacturers.

The standard adopts the International Electro-technical Commission (IEC)'s safety requirements for electrical heat pumps, air-conditioners and dehumidifiers containing

flammable refrigerants (IEC 60335-2-40:2005). Compared with the old version (GB 4706.32-2004) released in 2005, the 2012 version of the safety standard sets out detailed rules for safe operation, relating to safety warnings, transportation, installation, storage and charging of flammable refrigerants. The standard applies to heat pumps equipped with electric motors, compressors or room fan-coil units (including domestic hot water heat pumps), air-conditioners and dehumidifiers. The maximum rated voltage for a single unit cannot exceed 250V and the maximum rated voltage for other units cannot be more than 600V.

New standards and training underway to cover R290

Currently, the government is in the process of regulating and modifying additional standards regarding installation and maintenance, production line safety and transport safety. These standards will be modified further, to cover the use of flammable refrigerants such as R290. The Ministry of Environmental Protection is also working with companies to train engineers in the safe use of hydrocarbons, while National Professional Assessment Management associations are working with the Chinese government to include flammable refrigerants in the technology assessments for HCFC replacement alternatives. This will focus mostly on the safe handling of flammable refrigerants and creating additional knowledge about alternative

refrigerants.

In July 2013, the Shanghai Quality Supervision, Inspection and Quarantine Bureau established China's largest and first explosion-proof laboratory for refrigeration R290 RAC testing. The test centre is part of the government's effort to promote hydrocarbons as refrigerants in RACs production in China. Its key function is to undertake safety and energy efficiency tests for RACs using flammable refrigerants such as R290. It will examine the safety of R290 RAC produced by Chinese manufacturers, before models are placed on the market.



Exclusive interviews - Room air conditioning

WHAT WOULD YOU ADVISE THE CHINESE GOVERNMENT AND INDUSTRY TO DO TO ENSURE SAFE USE OF HYDROCARBONS IN CHINA?

**Professor Ma Yitai,
Tianjin University:**

In the production process, strict safety operating procedures have to be followed, as well as in repair procedures. To avoid hydrocarbon leakages, we can introduce special HC leak detectors. In small and medium volume refrigeration equipment, the hydrocarbons charge amount is relatively small but still safety measures have to be followed to avoid accidents. In large volume refrigeration facilities, I do not recommend using hydrocarbons.

**Wang Xunchang,
China Refrigeration and Air Conditioning Association (CRAA):**

For all the types of refrigerants there needs to be compulsory training and a certification system. Compulsory leakage detection equipment is also essential. This would allow regular checks in the case of hydrocarbon-based residential refrigerators. For hydrocarbons in room AC applications, the maximum refrigerant charge per unit should be regulated. In addition, strict safety requirements for the installation and the whole building should be put in place.

**Professor Shi Lin,
Tsinghua University:**

For hydrocarbons, we have to improve our risk assessment in the operational and maintenance environment. A better analysis of incident probability trees, as well as more experiments and tests with model units should be conducted. We need to gradually search for appropriate application fields to expand the use of hydrocarbon refrigerants steadily.

WHAT MEASURES IS THE FOREIGN ECONOMIC COOPERATION OFFICE (FECO) TAKING TO ENSURE SAFETY IN MANUFACTURING OF HYDROCARBON-BASED ROOM AIR CONDITIONING, BUT ALSO IN SAFE HANDLING AND MAINTENANCE OF SUCH EQUIPMENT?

**Zhong Zhifeng,
FECO:**

The Tianjin Fire Research Institution, Ministry of Public Security is conducting risk assessments to help effectively optimise the production process, servicing, transportation, installation, storage and disposal. As well as this, FECO together with the China Household Electronics Application Association are helping with training of servicing technicians, introducing safety standards and enforcing the development and application of safety measures in the production. Other measures include ensuring the safe handling of the system from installation to the end of its operation. So far, some developments have been achieved in this area, but more work regarding safety is necessary.

WHAT ARE THE MOST IMPORTANT BARRIERS IN CHINA AND INTERNATIONALLY IN THE INTRODUCTION OF NATURAL REFRIGERANT-BASED TECHNOLOGY?

**Zhong Zhifeng,
FECO:**

The main barriers to the introduction of natural refrigerant-based technology are international standards and the lack of experience in flammable refrigerants. Practically speaking, another barrier is the higher cost of the air conditioner itself when upgrading installations and servicing systems using natural refrigerants.

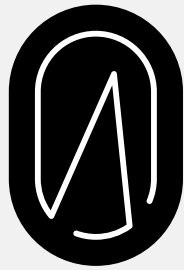

NORTH AMERICAN EDITION

ACCELERATE

ADVANCING HVAC&R NATURALLY MAGAZINE



- ★ First monthly North American magazine about natural refrigerant technology
- ★ Exclusive interviews with end users, suppliers, policy makers & more
- ★ For advertising benefits & options please contact franziska.menten@shecco.com

Don't miss an issue, read online today

accelerate.shecco.com

ACCELERATE JAPAN & ACCELERATE EUROPE COMING SOON

to find out how to get involved contact us sales@shecco.com

References

About natural refrigerants

- » Kalitzin N., Wobst E., and Apley R. (2004), Turbo Water Chiller with Water as Refrigerant, International Compressor Engineering Conference, 1625. School of Mechanical Engineering, Purdue University.
[ONLINE] Available at: <http://docs.lib.purdue.edu/cgi/viewcontent.cgi?article=2624&context=icec> [Accessed 13th December 2013]
- » Kilicarslan A. and Muller N. (2005), A comparative study of water as a refrigerant with some current refrigerants. International Journal of Energy Research. p. 29, 947 – 959.
[ONLINE] Available at: http://www.egr.msu.edu/mueller/NMReferences/MuellerKilicarslan2005_IntJEnergyRes_ComparativeStudyR718.pdf [Accessed 13th December 2013]
- » Heaney C, Swinard R., Pang A. and West S. (2007), Natural refrigerants case studies – information and case studies for Australian businesses, Australian Institute of Refrigeration, Air Conditioning and Heating (AIRAH). [ONLINE] Available at: <http://mail.airah.org.au/downloads/natural-refrigerants-case-studies.pdf> [Accessed 13th December 2013]
- » The Grimsby Institute (n.d) Air Cycle Refrigeration, Food Refrigeration & Process Engineering Research Center, The Grimsby Institute of Further & Higher Education.
[ONLINE] Available at: http://www.grimsby.ac.uk/documents/frperc/research/aircycle_research.pdf [Accessed 13th December 2013]
- » Venkatarathnam G. and Srinivasa Murthy S. (2012), Refrigerants for Vapour Compression Refrigeration Systems. Resonance, February, p. 139 - 162.
[ONLINE] Available at: <http://www.ias.ac.in/resonance/Volumes/17/02/0139-0162.pdf> [Accessed 31st January 2013]

Application of natural refrigerants in China TODAY – market, policy & technology overview

- » chem.hc360.com (2014), New Environmental Protection Law accelerate industry upgrade boosting talent demand.
[ONLINE] Available at: <http://info.chem.hc360.com/2014/05/201359425744.shtml> [Accessed 24th March 2015]
- » hydrocarbons21.com (2014), China: Household appliance industry should upgrade products to meet EU F-gas Regulation.
[ONLINE] Available at: http://www.hydrocarbons21.com/articles/5692/china_household_appliance_industry_should_upgrade_products_to_meet_eu_f-gas_regulation [Accessed 24th March 2015]
- » hydrocarbons21.com (2014), China's Chongqing launches pilot carbon market.
[ONLINE] Available at: http://www.hydrocarbons21.com/articles/5385/chinas_chongqing_launches_pilot_carbon_market [Accessed 24th March 2015]

- » hydrocarbons21.com (2014), China set to reduce HFC emissions by 280 million tonnes of CO₂ by 2015. [ONLINE] Available at: http://www.hydrocarbons21.com/articles/5346/china_set_to_reduce_hfc_emissions_by_280_million_tonnes_of_co2_by_2015 [Accessed 24th March 2015]
- » hydrocarbons21.com (2014), Chinese Ministry of Environmental Protection: More regulations for environmental protection will be released. [ONLINE] Available at: http://www.hydrocarbons21.com/articles/5907/chinese_ministry_of_environmental_protection_more_regulations_for_environmental_protection_will_be_released [Accessed 24th March 2015]
- » hydrocarbons21.com (2013), US & China agree to cooperate on phasing down HFCs. [ONLINE] Available at: http://www.hydrocarbons21.com/articles/4293/us_china_agree_to_cooperate_on_phasing_down_hfcs [Accessed 24th March 2015]
- » hydrocarbons21.com (2014), US-China climate deal could boost refrigerant market. [ONLINE] Available at: http://www.hydrocarbons21.com/articles/5855/us-china_climate_deal_could_boost_refrigerant_market [Accessed 24th March 2015]
- » hydrocarbons21.com (2013), With HCFCs “out”, Mexico and China share plans as of what is “in”. [ONLINE] Available at: http://www.hydrocarbons21.com/articles/4286/with_hcfc_out_mexico_and_china_share_plans_as_of_what_is_in [Accessed 24th March 2015]
- » Milner E., Mao C. (2015), Greener China is turning towards natural refrigerants, Accelerate America Issue 3, shecco Publishing. [ONLINE] Available at: <http://issuu.com/shecco/docs/aa1502-final/5?e=4239849/10938370> [Accessed 24th March 2015]
- » Ministry of Industry and Information Technology of the People’s Republic of China (2015), Seven ministries jointly publish “Top-runner” system action plan. [ONLINE] Available at: <http://www.miit.gov.cn/n11293472/n11293832/n11293907/n11368223/16400055.html> [Accessed 24th March 2015]
- » National Development and Reform Commission (2015), Regulation on Energy Efficiency Label for Lithium Bromide Absorption Chiller. [ONLINE] Available at: http://www.ndrc.gov.cn/zcfb/zcfbgg/201504/t20150407_672489.html [Accessed 7th May 2015]
- » National People’s Congress (2014), China Environmental Protection Law. [ONLINE] Available at: http://www.npc.gov.cn/npc/xinwen/2014-04/25/content_1861279.htm [Accessed 24th March 2015]
- » r744.com (2014), Chinese Ministry of Environmental Protection: Refrigerants give us chance to exceed other countries. [ONLINE] Available at: http://www.r744.com/articles/5703/chinese_ministry_of_environmental_protection_refrigerants_give_us_chance_to_exceed_other_countries [Accessed 24th March 2015]
- » The Central People’s Government of the People’s Republic of China (2012), 12th National Energy Technology Plan 2011-2015. [ONLINE] Available at: http://www.gov.cn/zwgk/2012-06/29/content_2172913.htm [Accessed 24th March 2015]
- » The Central People’s Government of the People’s Republic of China (2013), Opinions of the State Council on Accelerating Development of Energy Saving and Environmental Protection Industry. [ONLINE] Available at: http://www.gov.cn/zwgk/2013-08/11/content_2464241.htm [Accessed 24th March 2015]
- » The State Council (2014), Energy Resource Development Strategic Action Plan 2014-2020. [ONLINE] Available at: http://www.gov.cn/zhengce/content/2014-11/19/content_9222.htm [Accessed 24th March 2015]

An ecosystem approach

CITY & BUILDINGS

- » Hasse, V. and et al (2008), Natural Refrigerants, Sustainable Ozone – and Climate – Friendly Alternative to HCFCs, GTZ.
[ONLINE] Available at: <http://epa.gov/greenchill/downloads/en-gtz-proklima-natural-refrigerants.pdf> [Accessed 24th March 2015]
- » hydrocarbons21.com (2014), China: latest update on R290 RAC conversion progress.
[ONLINE] Available at: http://www.hydrocarbons21.com/articles/5894/china_latest_update_on_r290_rac_conversion_progress [Accessed 24th March 2015]
- » R744.com (2015), Carrier's CO₂ system addresses China's data centre demand. [ONLINE] Available at: http://www.r744.com/articles/6132/carrier_s_co_sub_2_sub_system_addresses_china_s_data_centre_demand [Accessed 24th March 2015]
- » R744.com (2012), CO₂ heat pumps are growing in popularity in China.
[ONLINE] Available at: http://www.r744.com/articles/co_sub_2_sub_heat_pumps_are_growing_in_popularity_in_china [Accessed 24th March 2015]
- » R744.com (2014), CO₂ heat pumps save 37-50% electricity in railway stations in China's cold regions.
[ONLINE] Available at: http://www.r744.com/articles/co_sub_2_sub_heat_pumps_save_37-50_electricity_in_railway_stations_in_china_s_cold_regions [Accessed 24th March 2015]
- » R744.com (2014), Haier launches its first CO₂ Heat Pump Water Heater in China.
[ONLINE] Available at: http://www.r744.com/articles/5762/haier_launches_its_first_co_sub_2_sub_heat_pump_water_heater_in_china [Accessed 24th March 2015]
- » R718.com (2012), Solar powered adsorption systems enter air conditioning and refrigeration market.
[ONLINE] Available at: http://www.r718.com/articles/solar_powered_adsorption_systems_enter_air_conditioning_and_refrigeration_market [Accessed 24th March 2015]

INDUSTRY, SPECIAL APPLICATIONS & SPORTS

- » ammonia21.com (2014), CTC builds first ice-training center using ammonia.
[ONLINE] Available at: http://www.ammonia21.com/articles/5685/ctc_builds_first_ice-training_center_using_ammonia_refrigerant_in_china [Accessed 24th March 2015]
- » ammonia21.com (2015), CTC Group: First large speed oval using ammonia refrigeration in China.
[ONLINE] Available at: http://www.ammonia21.com/articles/6138/ctc_group_first_large_speed_oval_using_ammonia_refrigeration_in_china [Accessed 24th March 2015]
- » ammonia21.com (2012), Johnson Controls leads the way for industrial cooling with naturals in China.
[ONLINE] Available at: http://www.ammonia21.com/articles/johnson_controls_leads_the_way_for_industrial_cooling_with_naturals_in_china [Accessed 24th March 2015]

- » ammonia21.com (2015), New developments rising to the surface as OTEC reaches new depths.
[ONLINE] Available at: http://www.ammonia21.com/articles/6032/new_developments_rising_to_the_surface_as_otec_reaches_new_depths [Accessed 24th March 2015]
- » hydrocarbons21.com (2012), Recent developments for hydrocarbon refrigerants in China.
[ONLINE] Available at: http://www.hydrocarbons21.com/articles/recent_developments_for_hydrocarbon_refrigerants_in_china [Accessed 24th March 2015]
- » R718.com (2015), Absorption Chiller installed at Chinese Power Generation Plants.
[ONLINE] Available at: http://www.r718.com/articles/6112/div_absorption_chiller_installed_at_chinese_power_generation_plants_div_div_div [Accessed 24th March 2015]

FOOD CHAIN

- » ammonia21.com (2012), China builds Asia's largest productive cold storage.
[ONLINE] Available at: http://www.ammonia21.com/articles/china_builds_asia_s_largest_productive_cold_storage [Accessed 24th March 2015]
- » ammonia21.com (2014), China: Gustav Lorentzen: NH₃/CO₂ system development in China.
[ONLINE] Available at: http://www.ammonia21.com/articles/gustav_lorentzen_nh_sub_3_sub_co_sub_2_sub_system_development_in_china [Accessed 24th March 2015]
- » ammonia21.com (2013), Yunnan builds the largest ammonia distribution centre.
[ONLINE] Available at: http://www.ammonia21.com/articles/yunnan_builds_the_largest_ammonia_distribution_centre [Accessed 24th March 2015]
- » R744.com (2013), China launches third CO₂ supermarket in Xiamen.
[ONLINE] Available at: http://www.r744.com/articles/china_launches_third_co_sub_2_sub_supermarket_in_xiamen [Accessed 24th March 2015]
- » R744.com (2013), Largest NH₃/CO₂ cascade cold storage plant launched in Zhangzi Island of China.
[ONLINE] Available at: <http://www.r744.com/news/view/4412> [Accessed 24th March 2015]
- » R744.com (2014), Metro opens first CO₂ store in China.
[ONLINE] Available at: http://www.r744.com/articles/5940/metro_opens_first_co_sub_2_sub_store_in_china [Accessed 24th March 2015]

Overview of key applications in the Chinese market

INDUSTRIAL REFRIGERATION

- » ammonia21.com (2014), Ammonia safety in China focuses at Gustav Lorentzen 2014 conference.
[ONLINE] Available at: http://www.ammonia21.com/articles/5670/ammonia_safety_in_china_in_focus_at_gustav_lorentzen_2014_conference [Accessed 24th March 2015]
- » ammonia21.com (2014), Business opportunities in the Chinese cold chain market.
[ONLINE] Available at: http://www.ammonia21.com/articles/business_opportunities_in_the_chinese_cold_chain_market [Accessed 24th March 2015]
- » ammonia21.com (2012), China will release the first safety standard for cold stores.
[ONLINE] Available at: http://www.ammonia21.com/articles/china_will_release_the_first_safety_standard_for_cold_stores [Accessed 24th March 2015]
- » ammonia21.com (2012), Chinese code for cold store is not enough to ensure ammonia safety.
[ONLINE] Available at: http://www.ammonia21.com/articles/chinese_code_for_cold_store_is_not_enough_to_ensure_ammonia_safety [Accessed 24th March 2015]
- » ammonia21.com (2014), Danfoss talks energy efficiency, charge reduction & safety.
[ONLINE] Available at: http://www.ammonia21.com/articles/5705/danfoss_talks_energy_efficiency_charge_reduction_safety [Accessed 24th March 2015]
- » ammonia21.com (2014), Exclusive interview Christian Overgaard, Danfoss China President.
[ONLINE] Available at: http://www.ammonia21.com/articles/5358/exclusive_interview_christian_overgaard_danfoss_china_president [Accessed 24th March 2015]
- » ammonia21.com (2014), Gustav Lorentzen: NH₃/CO₂ system development in China.
[ONLINE] Available at: http://www.ammonia21.com/articles/5716/gustav_lorentzen_nh_sub_3_sub_co_sub_2_sub_system_development_in_china [Accessed 24th March 2015]
- » ammonia21.com (2014), Moving toward safe ammonia usage in China.
[ONLINE] Available at: http://www.ammonia21.com/articles/5553/moving_toward_safe_ammonia_usage_in_china [Accessed 24th March 2015]
- » International Association of Refrigeration Warehouses (2014), 2014 Global Cold Storage Capacity Report.
[ONLINE] Available at: <http://www.gcca.org/resources/publications/white-papers-reports/global-cold-storage-capacity/> [Accessed 24th March 2015]
- » General Administration on Quality Supervision, Inspection and Quarantine of the People's Republic of China and Standardization and Administration of the People's Republic of China (2012), Standards on Positive Displacement CO₂ Refrigerant Compressor (Unit) GB/T 29030-2012.

- » National Development and Reform Commission (2010), Agricultural Products and Cold Chain Development Plan. [ONLINE] Available at: <http://zfxgk.ndrc.gov.cn/Attachment/农产品冷链物流发展规划.pdf> [Accessed 24th March 2015]
- » Maratou, A. et al. (2013), GUIDE 2013: Examples of NH₃/CO₂ secondary systems for cold store operators, shecco publications. [ONLINE] Available at: <http://publication.shecco.com/publications/view/20> [Accessed 24th March 2015]
- » State Administration of Work Safety General Supervision of Fourth Division (2013), Training material for ammonia refrigeration company special treatment.
- » The National People's Congress of the People's Republic of China (2014), Food Safety Law (draft version). [ONLINE] Available at: http://www.npc.gov.cn/npc/xinwen/lfgz/flca/2014-06/30/content_1869695.htm [Accessed 24th March 2015]
- » Twilley, N. (2014), China's Expanding Cold Chain, The New York Times Magazine. [ONLINE] Available at: http://www.nytimes.com/2014/07/27/magazine/what-do-chinese-dumplings-have-to-do-with-global-warming.html?_r=0 [Accessed 24th March 2015]

COMMERCIAL REFRIGERATION

- » EPA (2014), Protection of stratospheric ozone: adjustments to the allowance system for controlling HCFC production, import and export 2015-2019. [ONLINE] Available at: http://www.epa.gov/ozone/title6/downloads/CAA_Part_82A_2060_AR04_Final_Rule_Pre-pub_version_for_web_10-16-14.pdf [Accessed 24th March 2015]
- » European Commission (2014), Regulation (EU) No 517/2014 of the European Parliament and of the Council of 16 April 2014 on Fluorinated greenhouse gases and repealing Regulation (EC) No 842/2006, Official Journal of the European Union.
- » Kanamaru, H. (2014), Aeon's activities to expand the installation of natural refrigerants, presentation at ATMOsphere Network Tokyo 2014. [ONLINE] Available at: <http://www.atmo.org/media.presentation.php?id=486> [Accessed 24th March 2015]
- » Masson, N. (2014), Natural refrigerants in Asia & the world, an overview of market and policy trends, presentation at ATMOsphere Asia 2015. [ONLINE] Available at: <http://www.atmo.org/media.presentation.php?id=503> [Accessed 24th March 2015]
- » R744.com (2013), China launches third CO₂ supermarket in Xiamen. [ONLINE] Available at: http://www.r744.com/articles/3830/china_launches_third_co_sub_2_sub_supermarket_in_xiamen [Accessed 24th March 2015]
- » R744.com (2012), Exclusive Interview: Beijing's first CO₂ refrigeration store to achieve 35% energy savings. [ONLINE] Available at: http://www.r744.com/articles/1626/exclusive_interview_beijing_s_first_co_sub_2_sub_refrigeration_store_to_achieve_35_energy_savings [Accessed 24th March 2015]
- » R744.com (2012), Exclusive Interview: China will shift to natural refrigerants in the next five years. [ONLINE] Available at: http://www.r744.com/articles/1631/exclusive_interview_china_will_shift_to_natural_refrigerants_in_the_next_five_years [Accessed 24th March 2015]

- » R744.com (2014), Metro opens first CO₂ store in China.
[ONLINE] Available at: http://www.r744.com/articles/5940/metro_opens_first_co_sub_2_sub_store_in_china [Accessed 24th March 2015]
- » R744.com (2011), Tesco opens its first CO₂ refrigeration store in China.
[ONLINE] Available at: http://www.r744.com/articles/1463/tesco_opens_its_first_co_sub_2_sub_refrigeration_store_in_china [Accessed 24th March 2015]
- » Uto, S (2014), Lawson's natural refrigerant (CO₂) technology, presentation at ATMOSphere Asia 2015.
[ONLINE] Available at: <http://www.atmo.org/media/presentation.php?id=506> [Accessed 24th March 2015]

LIGHT COMMERCIAL REFRIGERATION

- » CNFOL.com (2014), Haier commercial cabinets using green environmental protection strategy leads industry to upgrade.
[ONLINE] Available at: <http://news.cnfol.com/chanyeijingji/20141110/19421103.shtml> [Accessed 24th March 2015]
- » Coca-Cola Company (2014), Collaborating and Moving Forward.
[ONLINE] Available at: <http://www.coca-colacompany.com/collaborating-and-moving-forward> [Accessed 24th March 2015]
- » European Commission (2014), Regulation (EU) No 517/2014 of the European Parliament and of the Council of 16 April 2014 on Fluorinated greenhouse gases and repealing Regulation (EC) No 842/2006, Official Journal of the European Union.
- » Fushun.nen.com.cn (2014), R290 Green and energy saving provides the great cold chain supply base.
[ONLINE] Available at: <http://fushun.nen.com.cn/system/2014/03/31/012081800.shtml> [Accessed 24th March 2015]
- » PepsiCo (2011), Performance with Purpose - Sustainability Report PepsiCo, Greater China 2011.
[ONLINE] Available at: <http://www.pepsico.com.cn/downloads/pdfs/kechixuReportEnglish.pdf> [Accessed 24th March 2015]
- » Ranson, J. (2015), Accelerate America Issue 4, EPA approves more uses of hydrocarbons, shecco Publishing.
[ONLINE] Available at: <http://publication.shecco.com/publications/view/72#view> [Accessed 24th March 2015]
- » Red Bull (2015), Implementing hydrocarbons in the global Red Bull cooler fleet, presentation at ATMOSphere Europe 2015.
[ONLINE] Available at: http://www.atmo.org/presentations/files/308_2_BRENNEIS_RED_BULL.pdf [Accessed 24th March 2015]

HEAT PUMPS

- » CHEAA.com (2015), Room air conditioner low-GWP label released in Shanghai.
[ONLINE] Available at: <http://news.cheaa.com/2015/0313/438843.shtml> [Accessed 24th March 2015]
- » Ministry of Industry and Information Technology (2014), Seven Ministries and Departments release “Top-runner” Practice Plan.
[ONLINE] Available at: <http://www.miit.gov.cn/n11293472/n11293832/n11293907/n11368223/16400055.html> [Accessed 24th March 2015]
- » People’s Government Guangdong Province (2014), Guangdong Provincial Government’s Opinion on Energy Saving and Environmental Protecting Industry Development Promotion.
[ONLINE] Available at: http://zwgk.gd.gov.cn/006939748/201408/t20140805_540666.html [Accessed 24th March 2015]
- » R744.com (2011), New Chinese CO₂ heat pump standard.
[ONLINE] Available at: http://www.r744.com/articles/1438/new_chinese_co_sub_b_2_b_sub_heat_pump_standard [Accessed 24th March 2015]
- » R744.com (2014), Pump it up! Significant growth in Chinese CO₂ heat pump market.
[ONLINE] Available at: http://www.r744.com/articles/5881/pump_it_up_significant_growth_in_chinese_co_sub_2_sub_heat_pump_market [Accessed 24th March 2015]
- » R744.com (2012), Up to 50,000 CO₂ heat pumps in China – Shandong Melinda Interview.
[ONLINE] Available at: http://www.r744.com/articles/3438/up_to_50_000_co_sub_2_sub_heat_pumps_in_china_shandong_melinda_interview [Accessed 24th March 2015]
- » State Council (2014), 2014-2015 Energy Saving and Carbon Reduction Emission Action Plan.
[ONLINE] Available at: http://www.gov.cn/zhengce/content/2014-05/26/content_8824.htm [Accessed 24th March 2015]
- » State Council (2012), Press release on 12th Five-year Energy Saving and Environmental Protection Development Plan.
[ONLINE] Available at: http://www.gov.cn/zwgk/2012-06/29/content_2172913.htm, [Accessed 24th March 2015]
- » Technavio (2013), Heat pump market in China 2014 – 2018.
[ONLINE] Available at: <http://www.technavio.com/report/heat-pump-market-in-china-2014-2018> [Accessed 24th March 2015]
- » The Central People’s Government of the People’s Republic of China (2012), CO₂ Heat Pump Key Technology and Commercialization Completed Acceptance.
[ONLINE] Available at: http://www.gov.cn/gzdt/2012-10/22/content_2248422.htm [Accessed 24th March 2015]

ROOM AIR CONDITIONING

- » CHEAA (2015), Room air conditioner low-GWP label released in Shanghai.
[ONLINE] Available at: <http://news.cheaa.com/2015/0313/438843.shtml> [Accessed 24th March 2015]
- » ERCGRE.org (2011), Gree starts first R290 refrigerant production line for RAC start production.
[ONLINE] Available at: <http://www.ercgre.org/public/pop.jsp?id=417> [Accessed 24th March 2015]
- » Gloel, J et al. (2014), Green Cooling Technologies: Market trends in selected refrigeration and air conditioning sectors. GIZ GmbH.
- » hydrocarbons21.com (2014), China: Latest update on R290 RAC conversion progress.
[ONLINE] Available at: http://www.hydrocarbons21.com/articles/5894/china_latest_update_on_r290_rac_conversion_progress [Accessed 24th March 2015]
- » hydrocarbons21.com (2012), China releases national safety standard for flammable refrigerants.
[ONLINE] Available at: http://www.hydrocarbons21.com/articles/china_releases_national_safety_standard_for_flammable_refrigerants [Accessed 24th March 2015]
- » hydrocarbons21.com (2014), Chinese Ministry of Environmental Protection offers subsidy for R290 Air Conditioner production.
[ONLINE] Available at: http://www.hydrocarbons21.com/articles/5535/chinese_ministry_of_environmental_protection_offers_subsidy_for_r290_air_conditioner_production [Accessed 24th March 2015]
- » hydrocarbons21.com (2015), Godrej forging new pathways for hydrocarbons in India and beyond.
[ONLINE] Available at: http://www.hydrocarbons21.com/articles/6286/godrej_forging_new_pathways_for_hydrocarbons_in_india_and_beyond [Accessed 24th March 2015]
- » hydrocarbons21.com (2011), Lessons from Gree's R290 AC facility could help others set up similar projects.
[ONLINE] Available at: http://www.hydrocarbons21.com/articles/2692/lessons_from_gree_s_r290_ac_facility_could_help_others_set_up_similar_projects [Accessed 24th March 2015]
- » JARN (2014), World Compressor Market, Japan Air Conditioning, Heating & Refrigeration News Special Edition, February, Serial No. 541-S.

About the authors



Marc Chasserot

Publisher / Managing Director

Marc Chasserot is a specialist in natural refrigeration with over 10 years' experience in the HVAC&R sector. Firstly as Marketing Manager for the Norsk Hydro business unit specialised in CO₂ transcritical refrigeration and heating. He worked closely with several Japanese manufacturers selling the market innovative "CO₂ Ecocute heatpumps". In 2006 Marc founded the industry leading website for CO₂ cooling and heating experts worldwide, called www.R744.com. This was followed by three additional industry resources for hydrocarbons, water and ammonia. Since 2007 Marc is co-founder and Managing Director of shecco, an independent market development company specialised in bringing Natural Refrigerants 'faster to market', working with numerous companies worldwide. Marc has also chaired and organised several international workshops bringing together leading policy and industry experts to discuss 'how to bring natural refrigerants' faster to market, known as 'ATMOsphere'.



Nina Masson

Lead Author / Deputy Managing Director

Nina holds two Master's degrees in Business Management and in Environmental Management. After serving in a communications role for global energy supplier Norsk Hydro, she has, for the last 8 years, been working in the field of environmental technologies, where she has developed special expertise on natural refrigerants. Today, she is mostly active in business development for market intelligence and consultancy services, as well as special projects and publications. She has been drafting and supervising global studies on behalf of United Nations agencies, including UNEP and UNIDO, as well as served as project coordinator for various EU projects. Nina is Associate Member of the Institute of Environmental Management and Assessment (IEMA).

Klara holds a Master's degree in International Relations from the University of Economics in Bratislava, Slovakia and has a background in European studies and international economic relations. Before joining shecco, she worked at the European Commission and a small business association. At her current position, Klara coordinates team activities in shecco's Business Development department, including for market research, public affairs and international project services. She is an expert on following legislative developments with an impact on the heating and cooling industry at national, European and international level, and informs decision-makers about the latest trends in the field of natural refrigerants.



Klára Skačánová

Deputy Manager, Market Development



Caixia Mao

Junior Analyst, Market Development

Caixia Mao has a M.Phil in Development Studies from University of Oxford in U.K and B.A in Liberal Arts from Waseda University in Japan. With extensive experiences in research and living in China and Japan, she has native fluency in both Chinese and Japanese. As a Junior Analyst in shecco, she focuses on Chinese and Japanese markets in business and policy climate and technology development for natural refrigerants.

Robert Davidson is the holder of a Master's degree in Development Economics from the School of Oriental and African Studies, London. An interest in the future of energy led him to shecco where he works as a Junior Analyst in shecco's business development department. As a junior analyst he works in identifying trends in natural refrigerants and helping clients optimise their strategy in the HVAC&R market.



Robert Davidson

Junior Analyst, Market Development



FIND YOUR PLACE IN THE ATMOSPHERE

INTERACTIVE CONFERENCES BRINGING TOGETHER
DECISION MAKERS FROM INDUSTRY AND GOVERNMENT
TO CHANGE THE FUTURE OF NATURAL REFRIGERANTS.



**JOIN US AT
OUR EVENTS**

atmo.org

#ATMOEVENTS



guide
shecco publications

Get in touch with shecco's Market Development team to learn more about the market for natural refrigerants in China or find out how we can help you in gathering market intelligence and proactively building your business with our tailored market development services, to get your technology faster to market.

Email us at

research@shecco.com

Talk to us on the phone

(+32) 2 230 3700

Our mailing address

shecco Europe Rue Royale 15, 1000 Brussels, Belgium

shecco Japan Office 20 EGG JAPAN Shin-Marunouchi Building 10F Marunouchi 1-5-1, Chiyoda-ku 100-6590, Tokyo, Japan

shecco USA 570 Seventh Avenue, 18th Floor, New York, NY 10018 - USA

shecco Publishing 

© 2015 shecco Publishing. All rights reserved.