

SHC 2012

Analysis of the performance of a GAX hybrid (Solar - LPG) absorption refrigeration system operating with temperatures from solar heating sources

Mario A. Barrera^a, Roberto Best^b, Victor H. Gómez^b, Octavio García-Valladares^b, Nicolaz Velázquez^c, Jorge Chan^{a,*}

^aPosgrado en Ingeniería. Universidad Nacional Autónoma de México. Privada Xochicalco s/n CP 62580. Temixco Morelos. México1 Tel: +52-7773620090 ext. 38025.e-mail: mabch@cie.unam.mx, web: <http://www.cie.unam.mx>

^bCentro de Investigación en Energía - UNAM, Privada Xochicalco S/N, CP 62580, Temixco, Morelos, México

^cUniversidad Autónoma de Baja California, Calle de la Normal s/n, Insurgentes Este, Mexicali B.C.

Abstract

This paper presents the analysis of the experimental tests performed with an absorption refrigeration advanced Solar-GAX system, designed for 10.5 kW (3 Ton) of cooling using ammonia-water mixture. The system designed for operation at heat source temperatures of around 200°C, consists of an absorber and generator of a falling film type and air cooled finned tube condenser and absorber, being an option for areas with water scarcity. Heat source temperatures of 160 °C were established to simulate the conditions of using solar thermal concentrating technology to supply heat the system, this means the system operating at partial load. Cooling capacities from 3 to 7 kW were obtained, with an average coefficient of performance (COP) of 0.37. Thermal stability was rapidly reached, after only 15 minutes of operation.

© 2012 Published by Elsevier Ltd. Selection and peer-review under responsibility of the PSE AG

Keywords: Solar cooling; absorption; ammonia; GAX

1. Introduction

Solar energy can be used to partially or totally produce the thermal energy required to operate absorption refrigeration systems during the day and to compensate in the night with a second resource

* Corresponding author. Tel.: +52-777-3620090 ext 38025.

E-mail address: mabch@cie.unam.mx.

such as biomass, waste heat or any other heat source and even a conventional cooling system. This as an alternative to the increasing conventional energy demand for air conditioning worldwide, as the population seeks for better comfort conditions in their workplace and in their homes.

Nomenclature

AB	Absorber	GFD	Direct fired generator
AHX	Absorber Heat eXchange	h	Enthalpy
AT	Ambient temperature	HS	Heating system
CP	Specific heat	Q_{GE}	Heat generation
COP	Coefficient of performance	Q_{EV}	Heat evaporation
EVa	Expansion valve	SD	Diluted solution
F_w	Water flow	Tgen	Generation temperature
F_{oil}	Oil Flow	W_P	Working pump
GAX	Generator Absorption eXchange	ΔT	Difference of temperatures
Ge	Generator		

The use of conventional cooling systems have increased worldwide, a large numbers of mini-splits were sold during 2005-2010 by an increasing rate of 44 to 94.5 million units. [1]. Overall worldwide power consumption for air conditioning and refrigeration represent 15% of the total power consumed [2].

Simultaneously, the interest for new existing technologies which are eco-friendly with the environment has been already investigated by different research groups. These technologies are particularly related to the study of absorption systems in so called hybrid systems that are combinations of solar thermal energy and fossil fuels. Lamp and Ziegler (1998) discussed in their peer review paper that in air-conditioning business a strong correlation often exists between insolation and cooling requirements. Therefore, the interest in solar cooling by sorption systems has prevailed for several decades. Also the authors indicated that solar-assisted air conditioning could play will a vital role if an effort is made for a greater technological development of advanced solar collectors and cooling systems. [3]. Figueredo et al. (2005) carried out an energy analysis of a double stage lithium bromide/water absorption system which was able to cover a thermal demand of 200kW at temperature of 170 °C, it could be operated as a single stage system at around 90°C, utilizing a solar heating system comprised of 182 m² of vacuum tubes and as a double stage system with a water boiler operating at 160°C, demonstrating that they could have savings of 100 MWh and 22 tons of CO₂ emissions per year [4].

According to Broad Air Conditioning [5] they have in production an absorption refrigeration system which could be operated in an hybrid form with heat from solar collectors during the day using parabolic trough concentrators and a conventional source at night, such as: natural gas, waste heat, biogas. These systems have cooling capacity of 15 kW to 4650 kW.

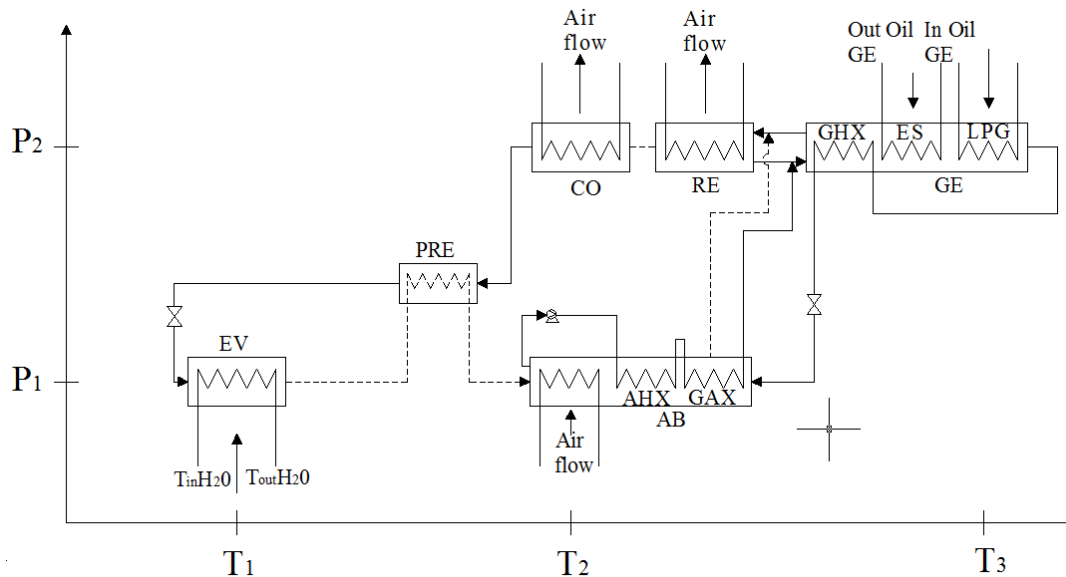

Fig. 1. Schematic diagram of the GAX absorption system prototype [6]

A paper published by Velázquez and Best (2002), indicated a methodological analysis and energy evaluation of an air cooled absorption system, with Generator–Absorber heat eXchange (GAX), this systems are characterized by recovering thermal energy during different sections of the absorption system instead of utilizing a solution heat exchanger, as well as in principle obtaining a higher performance in comparison to conventional absorption one stage ammonia-water absorption systems [6]. Jawahar and Saravanan (2010) presented a review of GAX absorption cooling systems with a comprehensive description of the different possible configurations, the working fluids and their coefficients of performance (COP), concluding that a COP up to 40% higher than a simple effect absorption system was possible, as well as seeing the development of GAX systems, as an alternative system for the future research [7].

Meanwhile Mortaza et al. (2012) compared the GAX and GAX hybrid absorption refrigeration cycles from the viewpoint of both first and second law of thermodynamics. They found that in both cycles the generator temperature (T_{gen}) has more influence on the second law efficiency whereas, the coefficient of performance (COP) of the cycles are comparatively less affected by generator temperature [8]. In turn Ali et al. (2012) proposed and investigated thermodynamically two GAX-ejector absorption refrigeration cycles. The comparison was performed through parametric studies in which the effects of generator and evaporator temperatures as well as the degassing range on the first and second law efficiencies were investigated [9].

The Centro de Investigación en Energía of Universidad Nacional Autónoma de México (UNAM), Mexico is developing a hybrid Solar-GAX absorption cooling plant prototype. This plant is designed for air conditioning which is shown schematically in Figure 3. The cooling system operates with the binary mixture ammonia-water, with a nominal capacity of 10.6 kW equivalents to 3 tons of cooling. The Solar-GAX system consists of a generator, rectifier, condenser, evaporator, an absorber, two expansion valves, and a solution pump. In order to reduce costs and have more compact equipment, the rectifier and the GHX heat exchanger section are coupled to the generator forming the generator-rectifier column. The coldest generator part, called GAX is coupled to the absorber forming to the absorber-GAX column,

shown in Figure 1. It is interesting to note that the Solar-GAX system does not require a cooling tower, because it is cooled ambient air. The ambient air helps to remove heat from the absorber, rectifier and condenser. This Solar-GAX system is configured to operate in a hybrid form with solar thermal energy, natural gas, or both. Previous work in this system has been already reported [10-11].

1.1. GAX system operational description

Figure 2 represents the refrigeration system GAX. In this operation system, ammonia vapour (99.3%), leaves the rectifier in process 15, saturated at the high pressure of the system. The refrigerant vapour was cooled and liquefied in the condenser as saturated liquid, process 16; then subcooled in the pre-cooler (process 17) and passes through an expansion valve, where the pressure was reduced, giving as a result a two phase cooled mixture process 18. The liquid ammonia entered into the evaporator, where extracting heat from the water to cool, it was converted into vapour, producing the refrigerating effect and then exits as saturated vapour in process 21 or in some instances with a little of liquid, this liquid was in greater proportion of water which was evaporated in the pre-cooler, leaving in process 22. The relatively cold ammonia vapour entered then the GAX-absorber column from the lower part, where it was condensed and absorbed in three different stages by means of the hot aqueous-ammonia solution. The dissolution of ammonia was exothermic, so heat exchange equipment in the absorber was included in order to cool the hot solution, improving its absorption capacity.

The foregoing was achieved by means of air cooling and the utilization of the same cold solution that leaves the absorber, as could be observed in Figure 2. The ammonia strong solution, leaves the GAX-absorber column in process 23 and enters into the pump, leaving at high pressure at process 24 and it was again introduced into the middle section of the (AHX) column, where it cools and receives heat from the absorber, leaving in process 28, entering the hottest part of the absorber (GAX section), in which upon receiving high-quality absorption heat, reaches the saturation point and vaporizes leaving at process 7, as a vapour-liquid mixture. The two phase high pressure mixture, enters the separation section of the generator-rectifier column, in which the liquid phase was incorporated into the condensed vapour originating from the rectifier (process 11) and entered the generator in process 10, in which heat was added in three sections (GHX, solar and natural gas) to finish the extraction of ammonia from the solution. The hot weak solution, leaves from the bottom of the generator-rectifier column in process 1, after that it was introduced again into the column to heat the GHX section of the generator, leaving in process 6, then its pressure was reduced through a valve, to leave (process 31). The still hot weak solution entered into the GAX-absorber column from the upper part, where it was put in contact counter currently against the ammonia vapour current in order to absorb it.

Returning to the generator, the release of ammonia vapour was accomplished in three stages and leaves the generator process 12, entering the separation chamber where it was joined with the vapour phase originating from the GAX-absorber column, resulting in process 13. The rising vapour current leave of the separation chamber and enters the rectifier, in which through heat removal and partial condensation, water was removed, leaving at process 15 as high purity ammonia. In this way the operation of the cycle was completely done. [6].

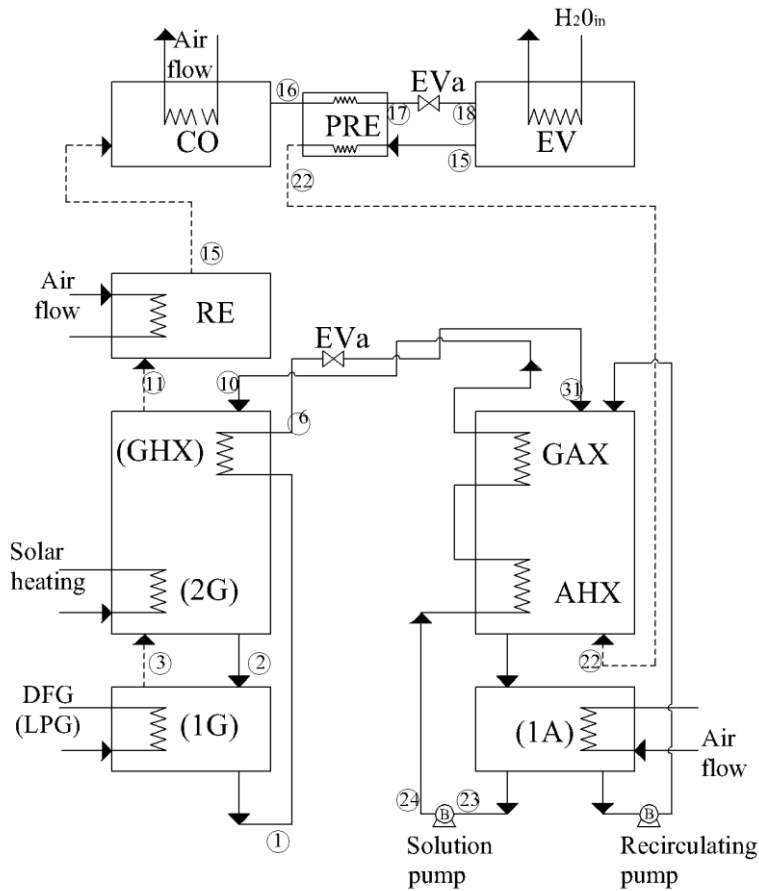

Fig. 2. Schematic diagram of the refrigeration system GAX

2. Methodology

As already explained, the system is designed to operate at generator temperatures above 200°C , in order to obtain the designed conditions of 10.5 kW and a COP close to 0.8, in this study, the system was operated at generator temperatures between 120 and 140°C using a heating source around 160°C , that can be achieved by parabolic troughs or very efficient CPC collectors.

As a heat source Mobiltherm 603 heating oil was used heated through an electric resistance heating loop with a 24 kW capacity as shown in figure 3 (a) and the prototype. PT sensors with an error of $\pm 0.1^{\circ}\text{C}$ were used to measure the inlet and outlet temperatures in every component. A heating inlet temperature was fixed around 160°C to maintain generator outlet solution temperatures of around 120 to 140°C . Flows were measured using an electromagnetic sensor turbine type with an error of $\pm 0.5\%$ (Flow technology brand) for heating oil and dilute solution and coriolis type with an error of 0.1% (Micromotion Elite mark) mass flow meters for refrigerant flows.

Considering these above operating conditions (generation) the maximum percentage of heat could be recovered in section GHX which is incorporated into the generator as shown in Figure 3. For this process

the outlet dilute solution (Ammonia/water) having mass flow rate of 1.8 kg / min enters into GHX and interchange of heat with concentrated solution (Ammonia/water) and enters to absorber. Secondly in evaporator enters water and ammonia with mass flow rate of 15 kg/min and 0.2 kg/min respectively. This process will help to know the maximum cooling capacity of the solar system GAX operating.

The Solar-GAX system can be operated not only with solar energy system but it also incorporates a direct-fired heating system shown in Figure 3 (b) which can use waste heat, biogas, LPG or natural gas.



Fig.3. (a) Connection diagram equipment heating; (b) system direct-fired generation

The COP was calculated using the equation 1 for the external cooling and heating loops, the chilled water loop consisting in the chilled water flow and the inlet and outlet chilled water temperatures from the evaporator plate heat exchanger and the heating oil loop, consisting of the oil flow and the inlet and outlet temperatures from the generator. Also the parasitic power of the fans and solution pump were considered.

$$COP = \frac{Q_{EV}}{Q_{GE+W}} \tag{1}$$

Where,

$$Q_{EV} = F_{NH3} * CP_W * \Delta T_W \tag{2}$$

$$Q_{GE} = F_{oil} * CP_{oil} * \Delta T_W \tag{3}$$

The specific heat of the heating oil was obtained from equations, proposed by the Mobiltherm manufacturer. For the calculation of the heat recovered in the GHX section, the ammonia water solution enthalpies were calculated by using the NIST program and data base, the flow rate was registered by the solution flowmeter.

$$Q_{GHX} = m_{SD} * (h_{SDin} - h_{SDout}) \tag{4}$$

3. Results

A series of tests were carried out at the aforementioned conditions, the plots represent tests where the experimental points are an average of twenty values captured during a time step of 1.6 minutes.

The heating oil inlet and outlet temperatures are shown in Figure 4 (a). The inlet temperature was around 160°C while the outlet temperature was below 120°C in the generator. Also shown are the weak ammonia solution outlet temperature that is also the inlet temperature to the GHX section, It can be seen that the solution leaves the GHX section around 100°C, which gives a heat recovery value of 3.05 kW. The pressure in the two sections were almost constant with slight increase in the low pressure as shown in Fig. 4(b), this could be a consequence of the increasing air temperature in the air-cooled absorber.

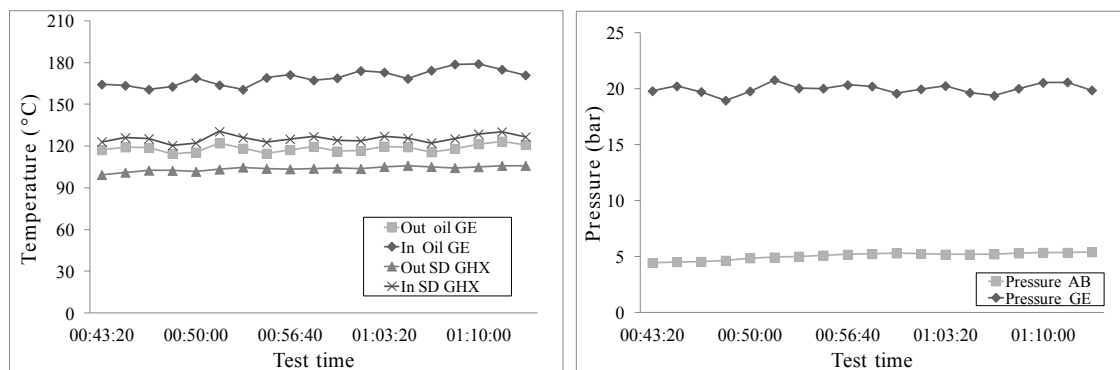

Fig. 4. (a) Generating temperature and temperature of the diluted solution GHX section; (b) Pressures in the GE and AB

The cooling capacity achieved was of 3.15 kW measured in the chilled water side and 4.2 kW calculated from an energy balance in the refrigerant ammonia refrigerant side. The evaporator temperatures are shown in Figure 5 (a) and the evaporator loads are shown in Figure 5 (b).

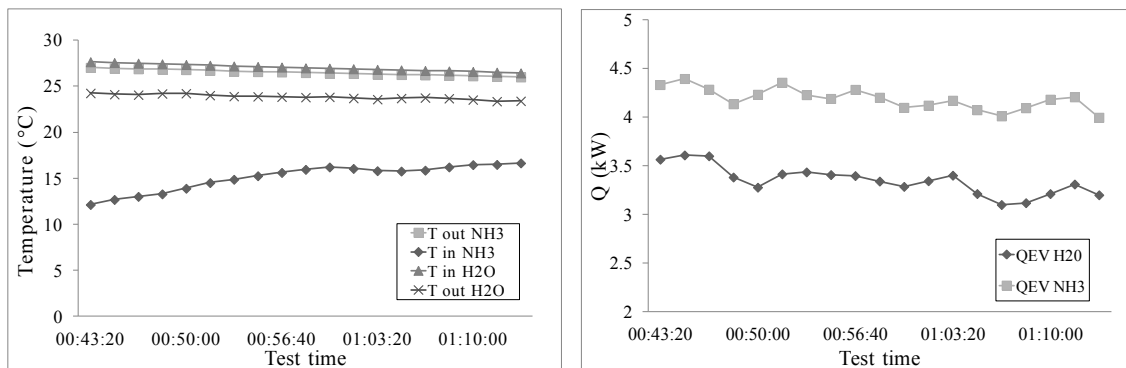

Fig. 5. (a) Temperature in the evaporator; (b) evaporation heat internally and externally

Table 1. Average heat loads calculated during the test as well as the COP values

Variable	Units	
Q_{EVNH3}	kW	4.00 ±0.10
Q_{EVH20}	kW	3.17 ±0.15
Q_{GE}	kW	20.96 ±2.40
$COP_{thermal}$	Adim	0.15 ±0.02
$COP + W$	Adim	0.132 ±0.019

Figure 6 shows the air temperatures during the test, it can be seen that the ambient temperature was higher than 30°C during the duration of the test, reaching values near 35°C. The inlet temperatures to the rectifier and absorber show a variation as they were affected by local conditions such as radiation from components and local heat effects. At the beginning of the tests the inlet air temperatures were within 0.1°C compared with the measured ambient temperature. The outlet air temperatures from the rectifier and absorber were 14 and 15°C higher than the inlet values.

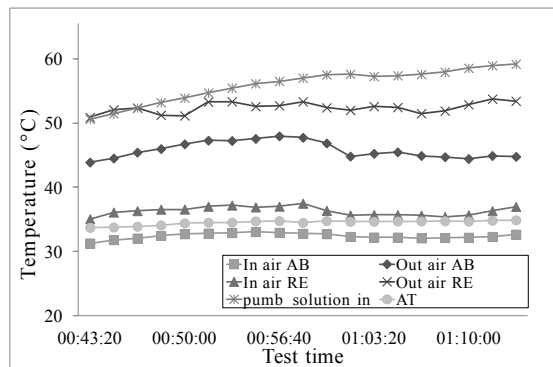

Fig. 6. Inlet and outlet air flow fans absorber and rectifier

Figure 7 (a) shows the behavior of heat generation and evaporation in a test which was used an average generation temperature of 160°C and was obtained in the dilute solution temperature of 140°C at ambient temperature of 28.5°C, this test was used the same water flow in the test described above by varying the ammonia mass flow in a range of 0.2 to 0.35 kg/min obtaining 7kW of cooling power. In Figure 7 (b) shows that it was possible to obtain COP of 0.5 under these conditions of operation.

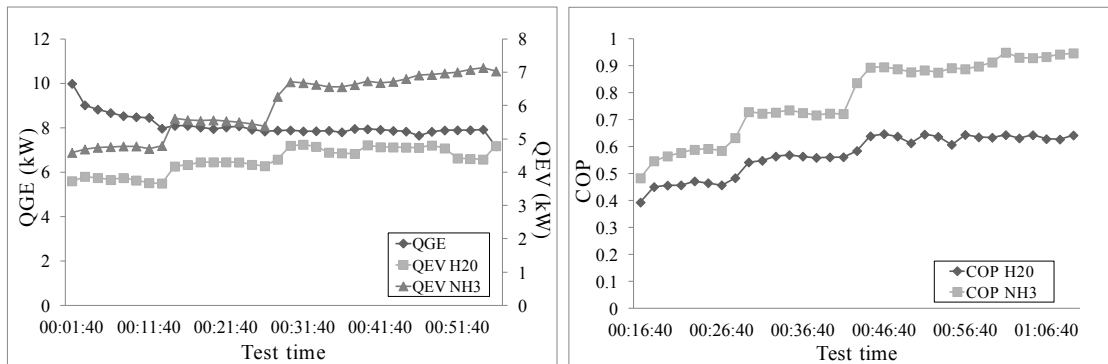

Fig 7. (a) Heat generation and evaporation; (b) thermal COP

4. Conclusions

A partial load of 3.17 kW with a COP value of 0.15 was obtained when operating the Solar-GAX system at generator temperatures of 120°C when the design of the operating generator temperature was 200°C with a design capacity of 10.5 kW. The system was operated with a heat source temperature of around 160°C instead of 220°C. The heat required for these conditions can be obtained by concentrating collectors such as parabolic troughs or efficient CPC collectors. The air cooled absorption system was operated at ambient temperatures above 30°C. Furthermore, at an ambient temperature of 28°C, 7kW cooling capacity was achieved, with a mass flow of ammonia of 0.35 kg/min and a water flow rate of 15 kg/min, with temperatures of the diluted solution at 140 ° C and under these conditions a COP of 0.2 to 0.3 was obtained for the water side and 0.25 to 45 on the ammonia side.

Acknowledgements

The authors would like to thank SENER-CONACyT project number 117914 for partially sponsoring the present study and the first author (MAB) expresses cordial gratitude to the Consejo Nacional de Ciencia y Tecnología (CONACyT) for his doctorate fellowship.

References

- [1] Mugnier, D. Task Description and work plan. Solar heating & cooling programme. *International Energy Agency*; 2011, p. 1-33.
- [2] Hong D, Tang L, He Y, Chen G. A novel absorption refrigeration cycle. *Applied Thermal Engineering*. 2010; **30**: 2045-2050.
- [3] Lamp P, Ziegler F. European research on solar-assisted air conditioning. *International Journal of refrigeration*. 1998; **21**: 89-99.
- [4] Figueredo G, Pérez de Viñaspre M, Bruno J, Bourouis M, Best R, Coronas A. Análisis energético de una instalación de climatización de absorción de doble etapa. XXIX Semana Nacional de Energía Solar; 2005: 303-309.
- [5] Energy Conservation Systems, Broad absorption Chiller, visit in June of 2012 <http://www.gqsltd.co.uk/Product.htm>.
- [6] Velázquez N, Best, R. Methodology for the energy analysis of an air cooled GAX absorption heat pump operated by natural gas and energy solar. *Applied Thermal Engineering*. 2002; **22**: 1089-1103.
- [7] Jawahar C, Saravanan R. Generator absorber heat exchange based absorption cycle- A review. *Renewable and Sustainable Energy Review*. 2010; **14**: 2372-2382.
- [8] Yari M, Zarin A, Mahmoudi S.M.S. Energy and exergy analyses of GAX and GAX hybrid absorption refrigeration cycles. *Renewable Energy*. 2011; **36**: 2011-2020.
- [9] Saberi Mehr A, Yari M, Mahmoudi S.M.S, Soroureddin A. A comparative study on GAX based absorption refrigeration systems: SGAX, GAXH and GAX-E. *Applied Thermal Engineering*. 2012; **44**: 29-38.
- [10] Gómez V.H, Vidal A, Best R, García-Valladares O, Velázquez N. Theoretical and experimental evaluation of an indirect-fired GAX cycle cooling system. *Applied Thermal Engineering*. 2008; **28**: 975-987.
- [11] García-Arellano C, García Valladares O, Gómez V. Experimental analysis of a transfer function for the transient response of an evaporator in an absorption refrigeration GAX system. *Applied Thermal Engineering*. 2010; **30**: 2026-2033.